

**REU-V3237WG-AK / REU-V3237WC-AK**

No.		RA Part No.	11 Digit Code	QTY
1	OUTER CASE		014-438-000	1
2	PLATE INSULATION		030-941-000	1
4	PANEL FRONT ASSEMBLY		019-3573000	1
7	BRACKET WALL MOUNTING		106-329-000	2
10	SEAL PANEL FRONT TOP	92086909	580-453-000	1
11	SEAL PANEL FRONT SIDE	92086917	510-903-000	2
12	CONNECTION REINFORCEMENT		044-154-000	1
13	BAG INSTALLATION MANUAL		600-051-000	1
14	BLIND GASKET		510-893-000	1
15	CABLE ENTRY (NEW) INF20	92073352	106-104-000	1
16	SEAL HARNESS	92099984	580-0105000	2
18	PLATE REINFORCEMENT		044-151-000	1
23	HARNESS EASY CONNECT		106-641-000	1
24	CONNECTION SUPPORT CLIP		538-840-000	1
100	INLET GAS 3/4	92081587	106-290-000	1
101	SCREW TEST POINT	90195157	501-275-005	2
102	GAS CONTROL ASSEMBLY		120-241-000	1
103	MANIFOLD LP	92095036	101-701-000	1
103	MANIFOLD NG	92095035	101-702-000	1
104	BURNER ASSEMBLY		000-140-000	1
105	DAMPER		140-775-000	1
107	BURNER CASE BOTTOM PLATE		004-564-000	1
108	BURNER CASE FRONT		098-985-000	1
109	PACKING		580-573-000	1
110	BURNER		157-090-000	22
111	BURNER CASE REAR PANEL		098-986-000	1
113	COMBUSTION CHAMBER FRONT		019-3389000	1
114	COMBUSTION CHAMBER PACKING		580-574-000	1
115	ELECTRODE	92086974	202-156-000	1
116	ELETRODE FR	92093640	230-057-000	1
117	PACKING ELECTRODE		580-0390000	1
118	ELECTRODE HOLDER RH	92087006	580-505-000	1
121	SLEEVE ELECTRODE	92087030	518-035-000	1
122	MAGNET VALVE COVER		098-0647000	1

123	COMBUSTION CHAMBER PACKING		092-046-000	1
124	COMBUSTION CHAMBER PACKING		092-047-000	1
125	HEAT EXCHANGER ASSEMBLY		314-696-000	1
131	FLUE EXHAUST		055-510-000	1
132	SEAL INNER FLUE	92096445	580-576-000	1
133	SEAL FLUE MAIN BODY	92096452	580-681-000	1
150	FAN COMBUSTION ASSEMBLY	92095022	222-534-000	1
151	FAN CASING	92098862	035-867-000	1
153	BRACKET FAN		106-649-000	1
154	PACKING FAN BRACKET		580-580-000	1
400	INLET WATER 3/4	92099968	333-301-NPB	1
401	PLUG BAND		553-119-000	1
402	FILTER WATER 0 LARGE	92083773	196-062-000	1
405	WATER FLOW SENSOR		301-163-000	1
406	RECTIFIER		330-107-000	1
407	BY-PASS SERVO ASSEMBLY		301-158-000	1
408	STOP BRACKET		512-401-000	2
409	WATER FLOW SENSOR COVER		098-1445000	1
410	OUTLET WATER 3/4		333-450-000	1
411	PLUG BAND		553-043-000	1
412	VALVE PRESS RELEIF	92081751	337-048-000	1
413	STOP BRACKET D		512-406-000	1
700	PCB MAIN	92087759	200-0471000	1
701	SURGE ARRESTOR	92093699	210-605-000	1
702	EC COVER		098-1869000	
703	PCB COVER SIDE		098-1844000	1
704	SPARKER BRACKET		538-0396000	1
705	SPARKER	92095026	261-157-000	1
706	LEAD HT	92092253	203-828-000	1
707	SPARKER COVER		098-1845000	1
708	HEATER ANTIFROST		235-376-000	1
709	BRACKET HEATER	92093301	538-493-000	2
710	HEATER FIXING PLATE		537-0440000	1
711	HEATER FIXING PLATE		537-215-000	1
712	HEATER VALVE		235-369-000	1
714	THERMAL FUSE		290-1273000	1
715	FIXING BAND A (F)		553-055-000	9

716	THERMISTOR	92095030	233-246-000	2
717	THERMISTOR CLIP	92086388	508-836-000	1
718	SWITCH THERMAL	92097187	234-444-000	1
720	HARNESS FUSE		290-1396000	
721	HARNESS POWER		204-0015000	1
722	HARNESS SPARKER		290-1398000	1
723	HARNESS SENSOR		290-1383000	1
724	ELEC CORD	92089051	206-226-000	1
725	HARNESS REMOTE		290-1399000	1
800	SCREW		501-889-000	3
800	TRUSS SCREW		501-973-010	1
801	RESIN WASHER		503-022-010	3
802	SCREW		501-0057000	2
803	PLASTIC WASHER		503-026-010	5
804	SCREW		501-0091000	8
805	SCREW		501-865-000	5
806	TAPPING SCREW		501-737-000	1
807	SCREW		501-0092000	5
808	SCREW		501-0064000	2
809	SCREW		501-0093000	3
810	THERMISTOR STOP SCREW		501-295-000	1
811	O RING GAS CONN	92072859	520-043-010	1
812	O RING IN/OUT WATER	92071182	520-049-010	3
813	O RING HEAT EXCH INLET	92062199	520-048-010	1
814	O RING HEAT EXCH OUTLET	92062207	520-193-010	2
815	O RING RELEIF VALVE	92062348	520-281-010	1
816	O RING THERMISTOR	92062249	520-209-010	2
817	O RING GAS MANIFOLD	92075126	580-202-000	1
818	O RING TEST POINT	90195165	520-300-010	1
821	HEXAGON HEAD SCREW		501-395-000	1
822	SCREW		501-799-000	4
823	HEXAGON SCREW		511-119-000	2
824	TRUSS FT SCREW		501-403-000	3
888	OPERATION MANUAL(RAU)		623-344-700	1
889	INSTALLATION MANUAL		K23-397-800	1

# REU-V3237WG-AK / REU-VM3237WC(65)-AK

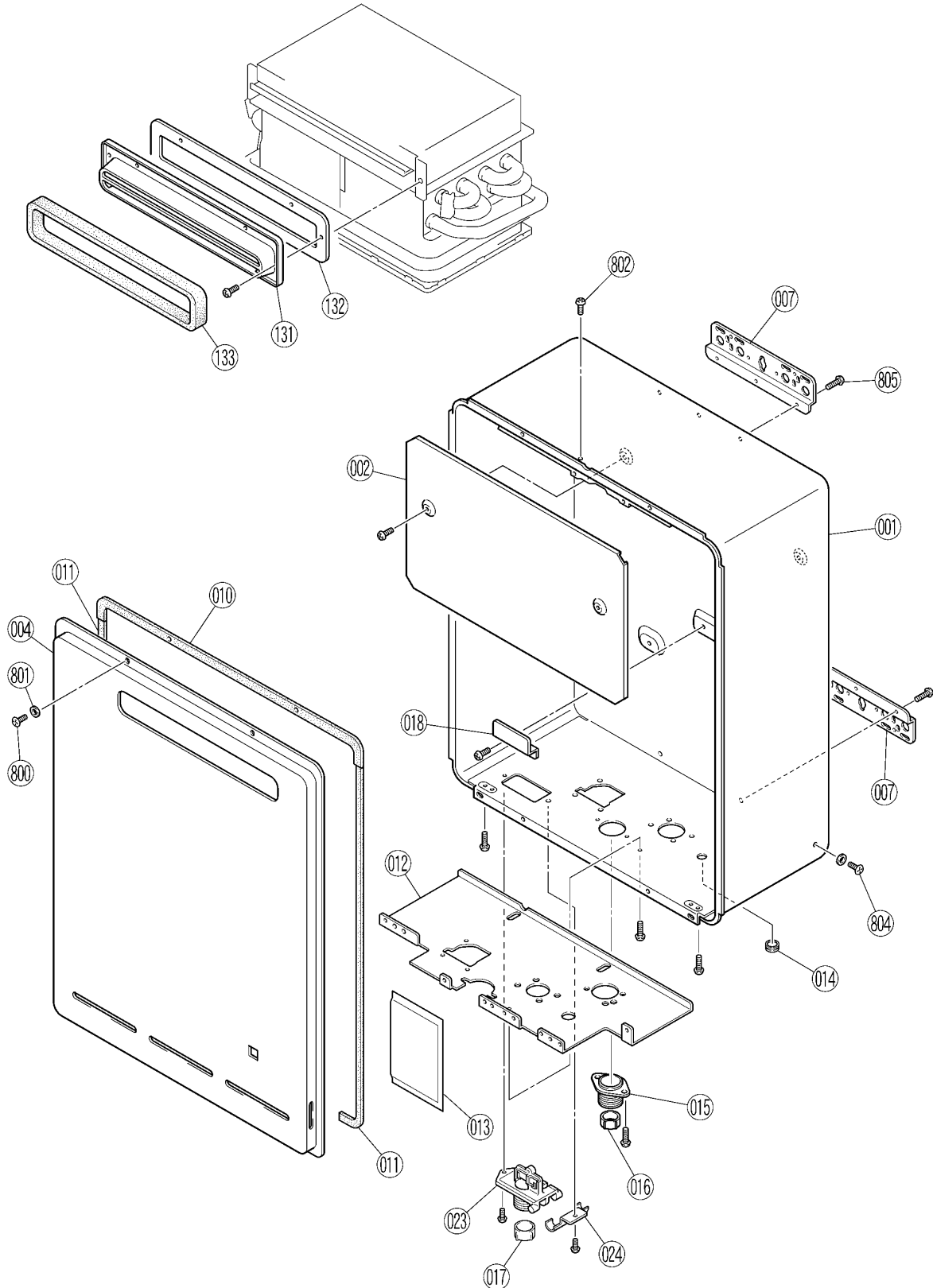

# REU-V3237WG-AK / REU-VM3237WC(65)-AK

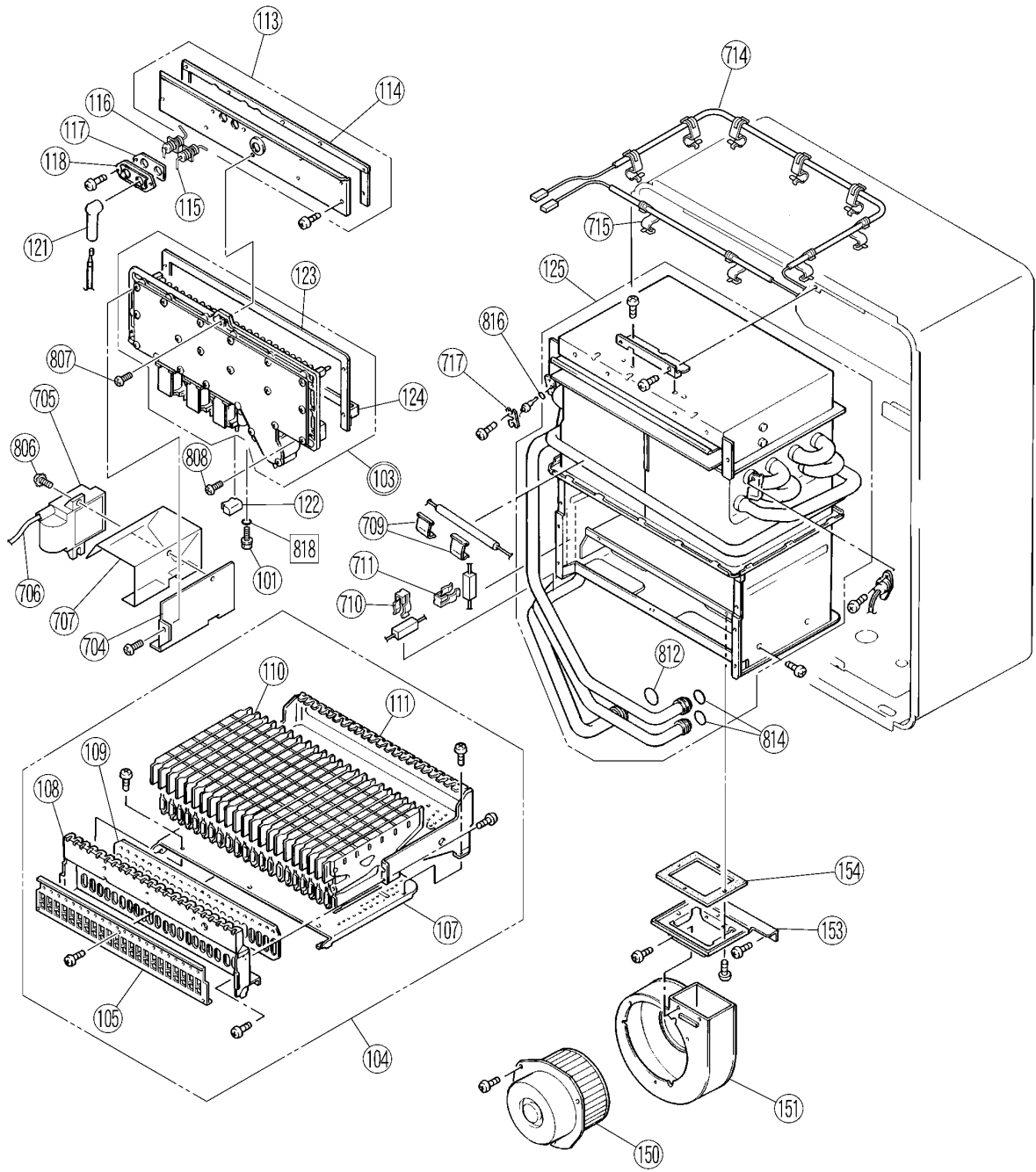

# REU-V3237WG-AK / REU-VM3237WC(65)-AK

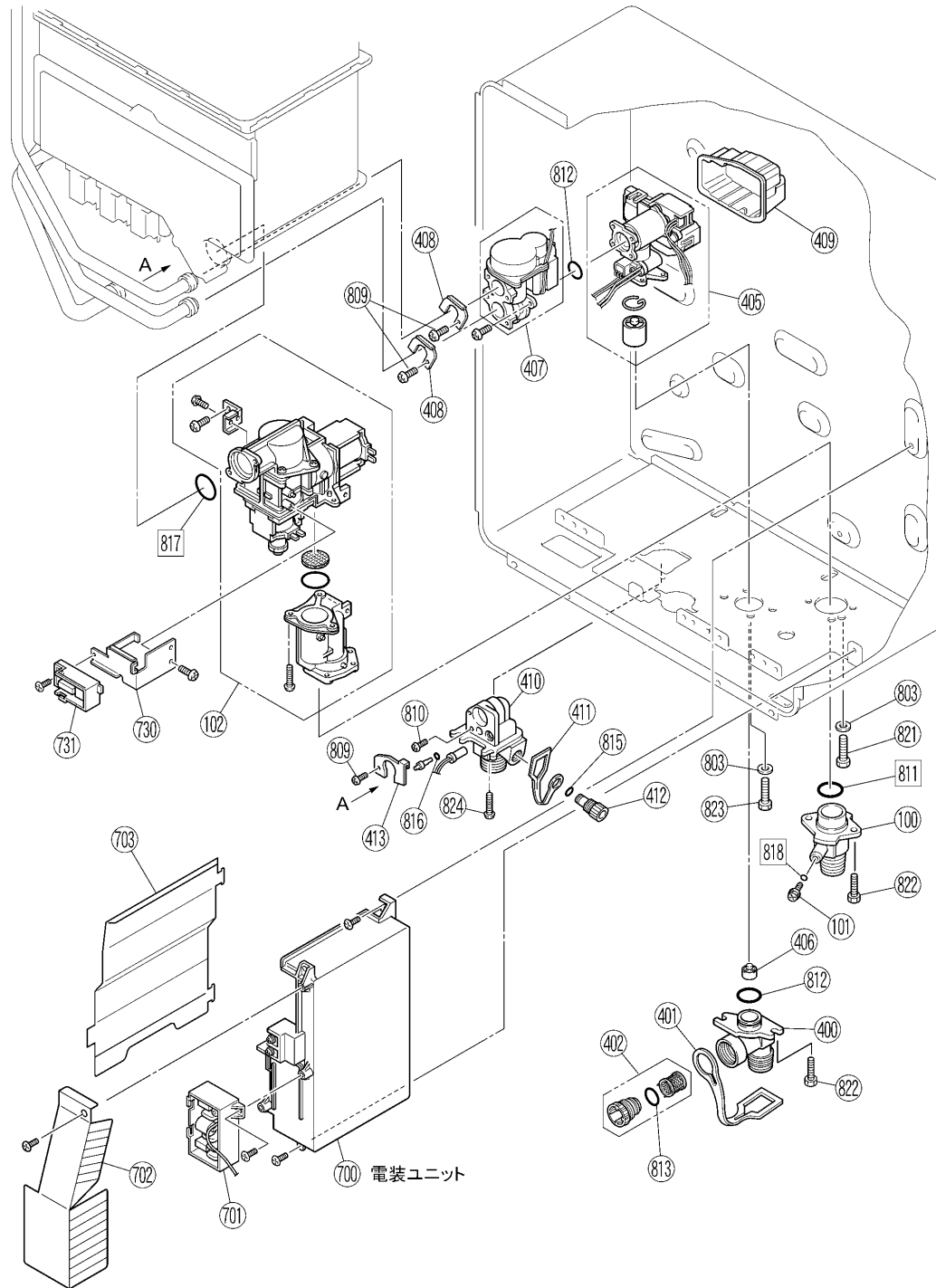

# REU-V3237WG-AK / REU-VM3237WC(65)-AK

