

REU-V1620WG-AK / REU-V1620WB-AK / REU-V1620WS-AK

NO	Part Name	RA Part No.	11 Digit Code	REU-V1620WG-AK	REU-V1620WB-AK	REU-V1620WS(60)-AK
				Quantity		
000	Outer Case			1	1	1
001	Panel Front	92099952	019-3426000	1		
001	Panel Front - Dune	92099953	019-3427000		1	
001	Panel Front - Dune	92099954	019-3435000			1
002	Panel Front Packing		580-0039000	3	3	3
010	Wall Hang Bracket		106-329-000	2	2	2
011	Blind Packing		510-893-000	1	1	1
012	Rubber Bushing C		194-140-000	1	1	1
013	Harness Easy Connect	92099955	106-651-000	1	1	1
014	Cable Seal Packing	92099984	580-0105000	1	1	1
015	Piping Reinforce		044-156-000	1	1	1
100	Inlet (3/4") Gas	92081587	106-290-000	1	1	1
101	Screw Test Point	92099956	501-275-005	2	2	2
102	Gas Control	92095018	120-0015000	1	1	1
103	Manifold LP	92093624	101-592-000	1	1	1
103	Manifold NG	92093632	101-593-000	1	1	1
104	Manifold Packing Upper		580-0106000	1	1	1
105	Manifold Packing Lower		580-0107000	1	1	1
106	Burner Case Front		098-0624000	1	1	1
107	Packing		580-589-000	1	1	1
108	Dumper		140-722-000	1	1	1
109	Lean & Rich Bunsen Burner Assy		157-083-000	14	14	14
110	Burner Case Rear		098-402-000	1	1	1
111	Combustion Chamber Front Panel		019-715-000	1	1	1
112	Combustion Chamber Front Panel Upper		580-591-000	1	1	1
113	Electrode	92086974	202-156-000	1	1	1
114	Electrode FR	92093640	230-057-000	1	1	1
115	Packing Electrode RH	92086990	580-507-000	1	1	1
116	Electrode Holder RH	92087006	580-505-000	1	1	1
117	Sleeve Electrode	92087030	518-035-000	1	1	1
120	Heat Exchanger	92093657	314-538-000	1	1	1
121	Water Connecting Tube Retainer		538-615-000	1	1	1

REU-V1620WG-AK / REU-V1620WB-AK / REU-V1620WS-AK

NO	Part Name	RA Part No.	11 Digit Code	REU-V1620WG-AK	REU-V1620WB-AK	REU-V1620WS(60)-AK
122	Bracket H/Exchanger Outlet	92099548	537-502-000	1	1	1
130	Exhaust Flue	92098466	055-787-000	1	1	1
131	Exhaust Opening Packing		580-593-000	1	1	1
132	Front Panel Seal Packing		580-594-000	1	1	1
150	Comb Assy	92093665	222-512-000	1	1	1
151	Fan Casing Assembly		035-870-000	1	1	1
400	Inlet (1/2") Water	92097906	333-300-000	1	1	1
401	Plug Band		553-119-000	1	1	1
402	Filter Water O Large	92083773	196-062-000	1	1	1
404	Rectifier		330-107-000	1	1	1
405	Water Flow Servo	92099957	301-152-000	1	1	1
406	Water Flow Servo Cover		098-1445000	1	1	1
408	Connection (1/2") H/W	92098458	333-303-000	1	1	1
409	Hot Water Plug Band		553-043-000	1	1	1
410	Valve Press Relief	92081751	337-048-000	1	1	1
700	PCB Main	92099958	200-0418000	1	1	1
701	EC Cover -2-A		098-1853000	1	1	1
701	EC Cover -2-Z		098-1854000			
702	Electric Control Cover		098-0627000	1	1	1
703	Sparker	92095026	261-157-000	1	1	1
704	Lead HT	92092253	203-828-000	1	1	1
705	Ignitor Bracket		537-0619000	1	1	1
706	Surge Arrestor	92093699	210-605-000	1	1	1
707	Sub Circuit Board Cover		098-1855000	1	1	1
708	Bracket		537-0618000	1	1	1
709	Elec Cord	92089051	206-226-000	1	1	1
710	Harness Fuse	92099959	290-1284000	1	1	1
711	Heater Anti frost	92098318	213-001-000	1	1	1
712	Switch Thermal	92097187	234-444-000	1	1	1
713	Heater Fixing Plate		537-0440000	4	4	4
715	Harness Power	92095027	290-1285000	1	1	1
716	Harness Magnet	92095028	290-1286000	1	1	1

REU-V1620WG-AK / REU-V1620WB-AK / REU-V1620WS-AK

NO	Part Name	RA Part No.	11 Digit Code	REU-V1620WG-AK	REU-V1620WB-AK	REU-V1620WS(60)-AK
717	Harness Sensor	92099960	290-1292000	1	1	1
718	Fuse Thermal	92098300	290-0491000	1	1	1
719	Thermal Fuse Fixing Plate		537-505-000	2	2	2
720	Thermal Fuse Fixing Plate		537-0110000	2	2	2
721	Sensor MR	92092279	243-072-000	1	1	1
722	Thermistor	92095030	233-246-000	1	1	1
725	Harness Remote Control	92099961	290-1288000	1	1	1
800	Earth Screw		501-889-000	1	1	1
801	Truss Screw		501-973-010	3	3	3
802	Screw		501-0064000	3	3	3
803	Tapping Screw		501-737-000	1	1	1
804	Thermistor Fixing Screw		501-295-000	1	1	1
820	O-Ring	90195165	520-300-010	2	2	2
821	O-Ring Gas Con	92072859	520-043-010	1	1	1
822	O-Ring Gas Control	92096502	580-180-000	2	2	2
825	O-Ring Thermistor	92062249	520-209-010	1	1	1
826	O-Ring	92062348	520-281-010	1	1	1
827	O-Ring Heat Exchanger	92072800	520-255-010	1	1	1
828	O-Ring Heat Exchanger	92062207	520-193-010	1	1	1
829	O-Ring Heat Exchanger Inlet	92062199	520-048-010	1	1	1
830	O-Ring In/Out Water	92071182	520-049-010	1	1	1
888	Operation Manual		623-344-700	1	1	1
889	Establishment Manual		K23-366-800	1	1	1

REU-V1620WG-AK / REU-V1620WB-AK / REU-V1620WS-AK

REU-V1620W/V2024W/V2015W/V2426W/V2626W-AK
REU-V1620W/V1818W/V2024W/VE2015WS/V2426W/V2422WS-ZK

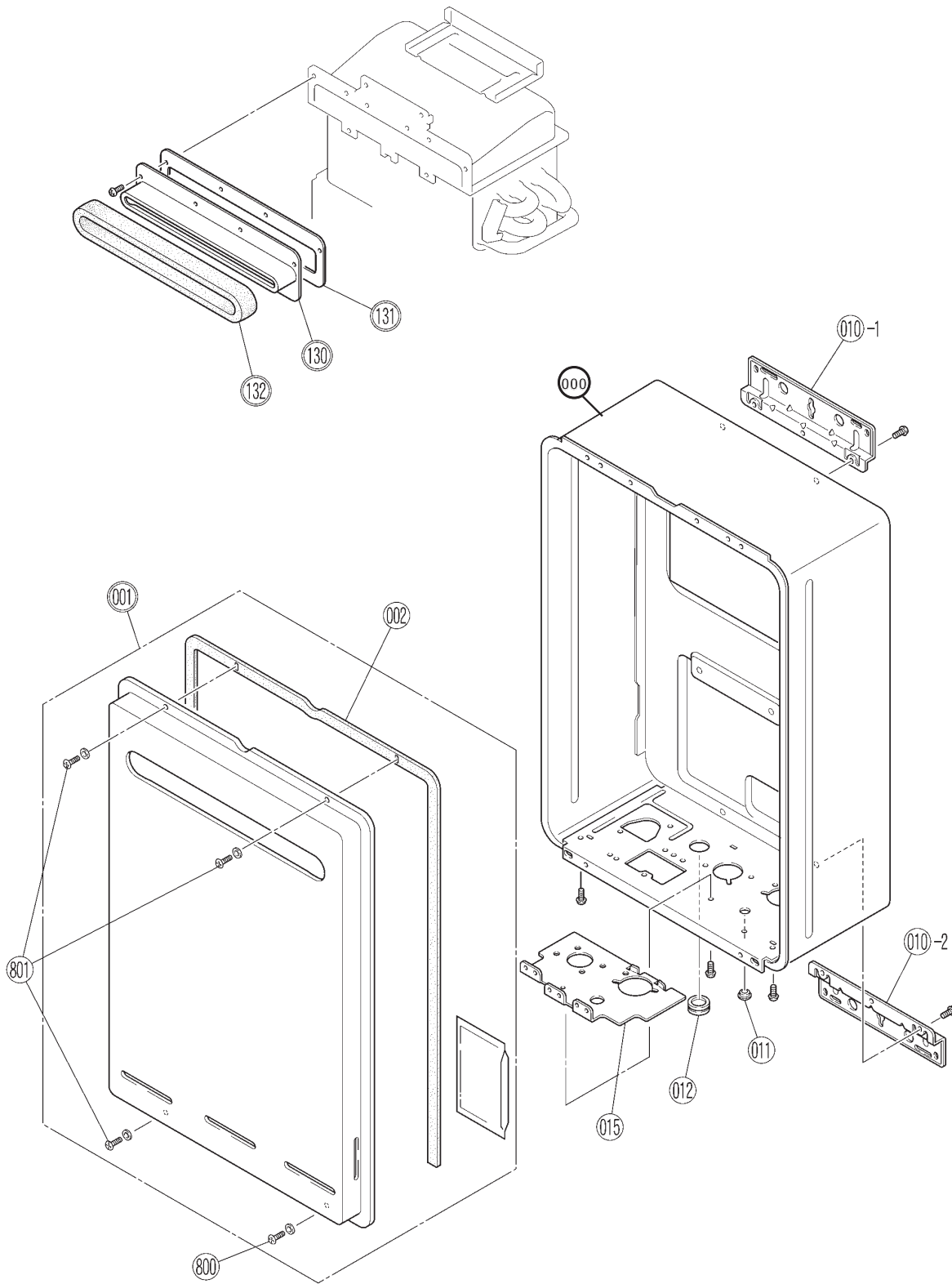

REU-V1620W/V2024W/V2015W/V2426W/V2626W-AK
 REU-V1620W/V1818W/V2024W/VE2015WS/V2426W/V2422WS-ZK

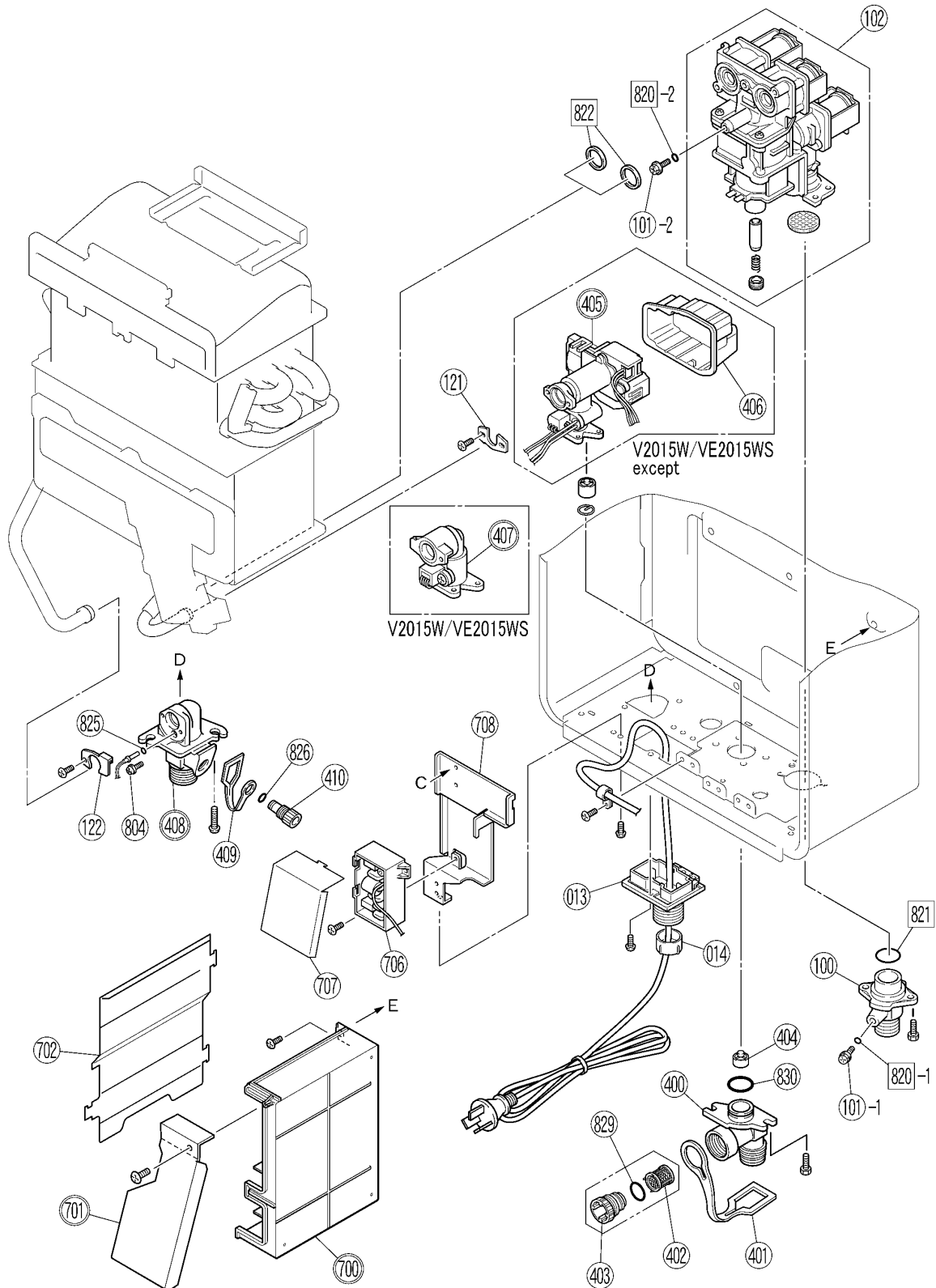

REU-V1620W/V2024W/V2015W/V2426W/V2626W-AK
 REU-V1620W/V1818W/V2024W/VE2015WS/V2426W/V2422WS-ZK

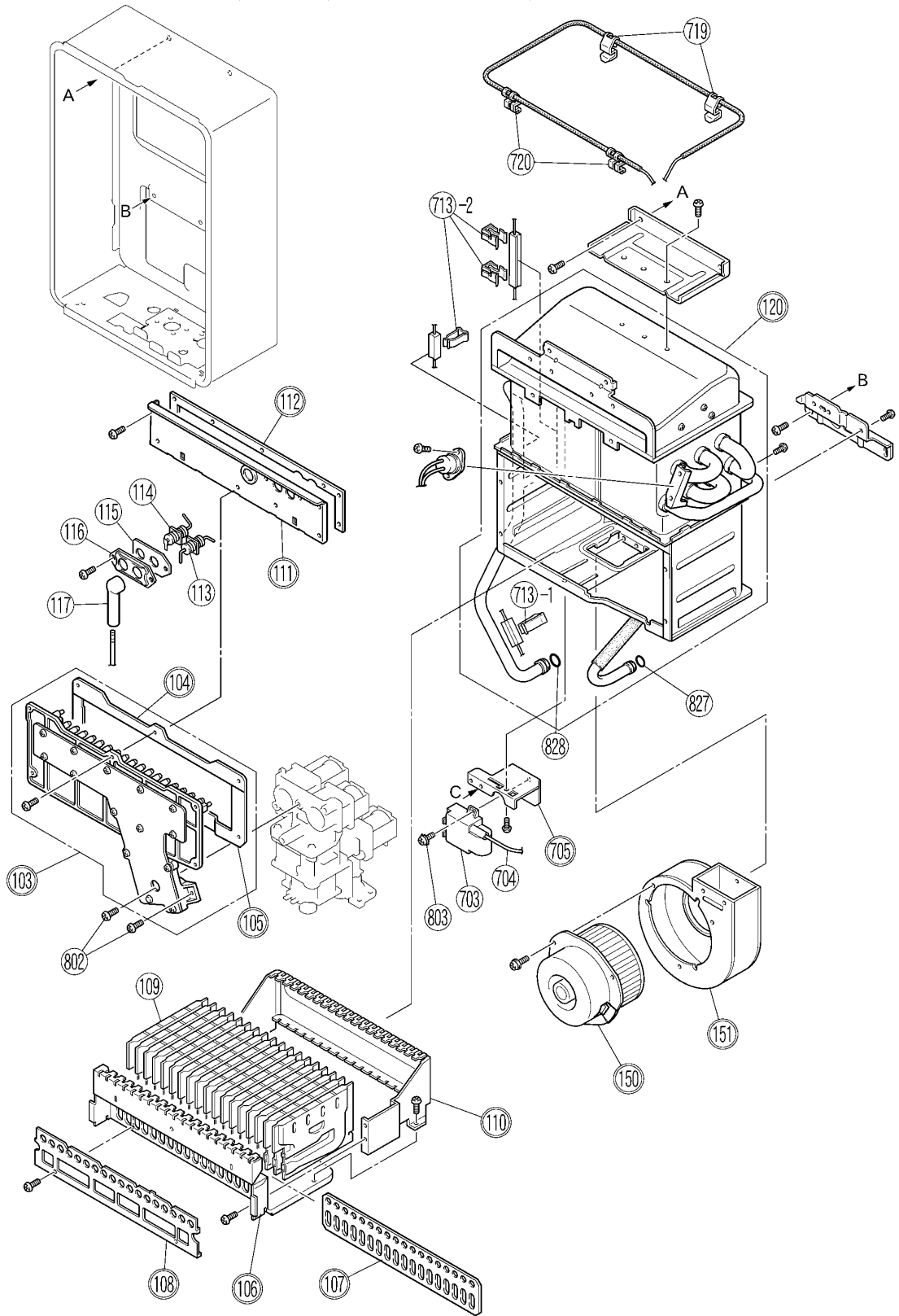

REU-V1620W/V2024W/V2015W/V2426W/V2626W-AK
REU-V1620W/V1818W/V2024W/VE2015WS/V2426W/V2422WS-ZK

