

# Rinnai

---

## SERVICE MANUAL

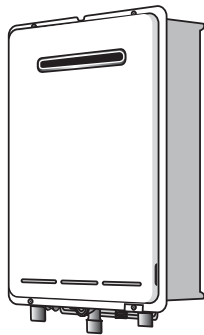

To Suit Models:

REU-V1620WG

REU-V1620WB

REU-V1620WS

REU-V2024WG

Does NOT Suit any other Models.



The Australian  
Gas Association

All Rinnai products are certified by the Australian Gas Association as compliant to relevant Australian Standards.



Distributed and serviced in Australia under a Quality System certified as complying with ISO 9001 by SAI Global

Rinnai Australia Head Office is certified as complying with ISO 9001 by SAI Global.



Quality  
Endorsed  
Company

ISO 9001 Reg 415

Rinnai New Zealand has been certified to ISO 9001 Quality Assurance by Telarc.

Certified  
Product



WaterMark

AS3498 Lic W208  
SAI Global

All Rinnai products are Certified to WaterMark by SAI Global. WaterMark certification is awarded to products and fittings complying with safety and water contamination standards.

© Copyright Rinnai Australia Pty Ltd ABN 74 005 138 769  
All rights reserved  
Produced by Engineering & Technical Group

*No portion or part of this manual may be copied without prior permission from Rinnai Australia.*

*Rinnai Australia reserves the right to make modifications and change specifications without notice.*



**W A R N I N G**



*Failure to comply with these instructions may result in serious personal injury or damage to the appliance.*



- All wiring inside this appliance may be at 240 Volts potential.
- All service work must be carried out by an authorised person.

*This manual has been published by Rinnai Australia Engineering & Technical Group.*

*We welcome users of this manual to provide feedback and suggestions for improvement purposes.*

# Glossary of Terms and Symbols

---

dB(A)	-	sound pressure level in decibels, “A” range
DC	-	direct current
AC	-	alternating current
WFCD	-	water flow control device
FB	-	feedback information
FF	-	feedforward information
Hz	-	Hertz
IC	-	integrated circuit
kPa	-	kilopascals
LED	-	light emitting diode
L/min	-	Litres per minute
mA	-	milliamps
MJ/h	-	megajoule per hour
mm	-	millimetres
OHS	-	overheat switch
PCB	-	printed circuit board
CPU	-	central processing unit
POT	-	potentiometer
rpm	-	revolutions per minute
SV	-	solenoid valve
∅	-	diameter
Δ °C	-	temperature rise above ambient
POV	-	modulating valve
TE	-	thermal efficiency
TH	-	thermistor
T <sub>IN</sub>	-	temperature of incoming water
T <sub>OUT</sub>	-	temperature of outgoing water

# Table of Contents

---

Glossary of Terms and Symbols .....	iv
1. Specifications .....	1
2. Water Flow Rates and Pressures .....	4
3. Dimensions .....	5
4. Water Controllers .....	6
5. Smartstart .....	8
6. Cutaway Diagram .....	10
7. Operational Flow Chart .....	11
8. Operation Principles .....	12
9. Main Components .....	13
10. Time Charts .....	14
11. Wiring Diagram .....	15
12. Dip Switch Settings .....	16
13. Fault Finding .....	17
14. Component and Circuit Checks .....	19
15. Gas Pressure Setting Procedure .....	23
16. Gas Conversion Procedure .....	23
17. Maintenance Monitor / Error History .....	24
18. Dismantling for Service .....	27
19. Parts List .....	36
REU-V1620WG / REU-V1620WB / REU-V1620WS .....	37
REU-V2024WG .....	40
20. Exploded Diagram .....	44

# 1. Specifications

Rinnai model number	<b>REU-V1620WG</b> <b>REU-V1620WB</b> <b>REU-V1620WS</b>
Type of appliance	Temperature controlled continuous flow gas hot water system
Exhaust system	Fan Forced Flue
Installation	External
Dimensions	Width - 350 mm Height - 530 mm Depth - 194 mm
Weight	15 kilograms
Gas consumption (Min. / Max.)	Natural gas : Approx. 18 ~ 125 MJ/h Propane gas : Approx. 18 ~ 125 MJ/h
Output (kW) (Maximum)	28 kW
Connections 1620WG / WB	Gas connection - R3/4 (20A) Cold water connection - R 1/2 (15A) Hot water connection - R 1/2 (15A)
1620WS	Cold water connection - R 3/4 (20A) Hot water connection - R 3/4 (20A)
Ignition system	Direct electronic ignition
Electrical consumption	Normal - 47 W Standby - 2 W (with 1 water control) Anti-frost protection - 74 W
Hot water capacity (Raised 25°C)	2.3 to 16 L/min
Temperature range (with controller)	Kitchen water controller : 37 ~ 55°C Bathroom water controller: 37 ~ 50°C
Delivery temperatures	40°C, 42°C, 50°C, 55°C, 65°C, 75°C (set by combination of dip switches on PCB) <b>NOTE: 1620WS must be preset to 60°C</b>
Water flow control	Water flow sensor, Electronic water flow control device
Maximum hot water capacity, raised @ 25°C	16 L/min
Water pressure required to achieve maximum hot water capacity	75 kPa
Maximum water flow	20 L/min
Water pressure required to achieve maximum hot water flow	120 kPa
Minimum water flow	2.4 L/min
Power supply	Appliance - AC 240 Volts 50 Hz Water controller - DC 12 Volts
Water controllers (optional) Water controllers not compatible with 1620WS	A maximum of 4 water controllers can be fitted. Any combination of deluxe, universal and wireless controllers can be used with the following limitations: Only ONE master controller can be installed. This can be a MC-100V, a MC-91Q (when programmed as a mater controller) or a MC-502RC/ MC-503RC water controller. Up to TWO BC-100V water controllers can be installed. The FOURTH water controller in any installation MUST be a MC-502RC / MC-503RC or a MC-91Q.
Water Controller Cable	Cables are supplied with water controllers. Alternatively, two core sheathed (double insulated) flex with minimum cross sectional area of 0.5 m <sup>2</sup> may be used. Maximum individual cable runs should not exceed 50 m.

<b>Rinnai model number</b>	<b>REU-V2024WG</b>
Type of appliance	Temperature controlled continuous flow gas hot water system
Exhaust system	Fan Forced Flue
Installation	External
Dimensions	Width - 350 mm Height - 530 mm Depth - 194 mm
Weight	15 kilograms
Gas consumption (Min. / Max.) REU-V1620WG / REU-V1620WB	Natural gas : Approx. 20 ~ 160 MJ/h Propane gas : Approx. 20 ~ 160 MJ/h
Output (kW) (Maximum)	35.5 kW
Connections	Gas connection - R3/4 (20A) Cold water connection - R 3/4 (20A) Hot water connection - R 3/4 (20A)
Ignition system	Direct electronic ignition
Electrical consumption	Normal - 65 W Standby - 2 W (with 1 water control) Anti-frost protection - 100 W
Delivery temperatures	40°C, 42°C, 50°C, 55°C, 65°C, 75°C (set by combination of dip switches on PCB)
Water flow control	Water flow sensor, electronic water flow control device
Maximum hot water capacity, raised @ 25°C	20 L/min
Water pressure required to achieve maximum hot water capacity	120 kPa
Maximum water flow	24 L/min
Water pressure required to achieve maximum water flow	160 kPa
Minimum water flow for operation	2.4 L/min
Power supply	Appliance - AC 240 Volts 50 Hz Water controller - DC 12 Volts
Water controllers (optional) - Wireless water controller only installations - Wired & Wireless Water Controller Installations	A maximum of 4 water controllers can be fitted. Any combination of deluxe, universal and wireless controllers can be used with the following limitations: Only ONE master controller can be installed. This can be a MC-100V, a MC-91Q (when programmed as a mater controller) or a MC-502RC/ MC-503RC water controller. Up to TWO BC-100V water controllers can be installed. The FOURTH water controller in any installation MUST be a MC-502RC / MC-503RC or a MC-91Q.
Water Controller Cable	Cables are supplied with water controllers. Alternatively, two core sheathed (double insulated) flex with minimum cross sectional area of 0.5 m <sup>2</sup> may be used. Maximum individual cable runs should not exceed 50 m.

## Sensors and Safety Functions

- **Hot Water Delivery Thermistor:** Measures hot water temperature at the outlet valve (i.e. the ‘mixed’ temperature).
- **Flame Rod:** Monitors combustion characteristics inside the combustion chamber. If the flame fails, gas supply is stopped.
- **Overheat Switch:** Situated on the heat exchanger, gas supply is stopped when water temperature reaches 97°C for a number of seconds.
- **Fusible Link:** Situated on the heat exchanger, electrical power supply is stopped if the temperature exceeds 129°C.
- **Water Pressure Relief Valve:** Safeguards the water circuit against excessive inlet pressure. Opens at 2060 kPa, closes at 1470 kPa.
- **Electrical Fuse:** (3A glass fuse) prevents against power surges.
- **Surge Protector:** prevents against over-current.
- **Boil Dry Prevention:** If water flow sensor detects no flow, gas supply is stopped.
- **Combustion Fan Speed Sensor:** In case of combustion fan defect (no rotation of fan blades) gas supply is stopped.
- **Temperature Cutout:** If the delivered hot water temperature rises above the required delivery temperature for a number of seconds, the gas supply is stopped.

## Combustion Specifications

Refer to dataplate on the appliance.



## 2. Water Flow Rates and Pressures

Water flow rate and pressure characteristics are shown below:

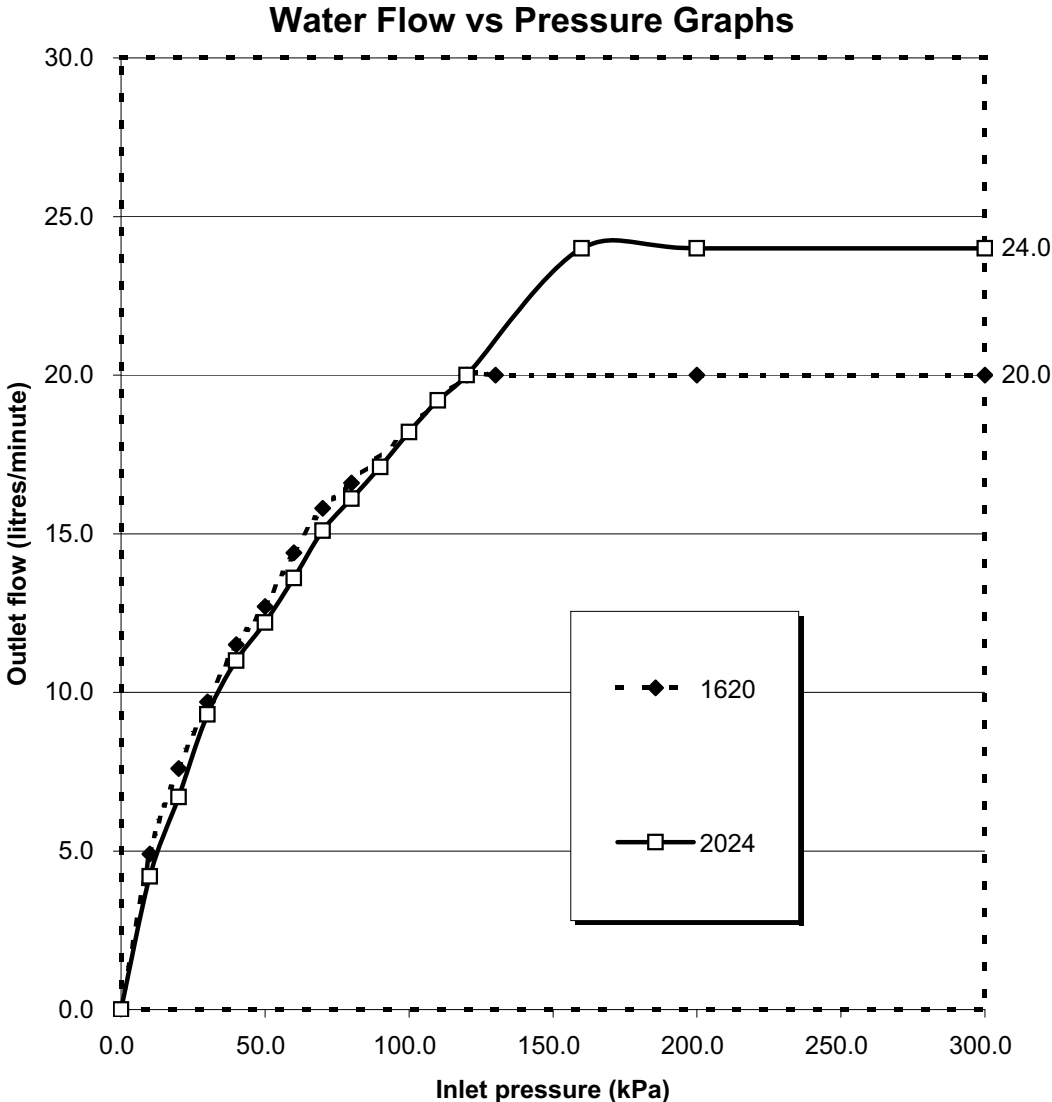

1620																
P(kPa)	0.0	10.0	20.0	30.0	40.0	50.0	60.0	70.0	80.0	120.0	130.0	200.0	300.0			
Q(L/min)	0.0	4.9	7.6	9.7	11.5	12.7	14.4	15.8	16.6	20.0	20.0	20.0	20.0			
2024																
P(kPa)	0.0	10.0	20.0	30.0	40.0	50.0	60.0	70.0	80.0	90.0	100.0	110.0	120.0	160.0	200.0	300.0
Q(L/min)	0.0	4.2	6.7	9.3	11.0	12.2	13.6	15.1	16.1	17.1	18.2	19.2	20.0	24.0	24.0	24.0

### 3. Dimensions

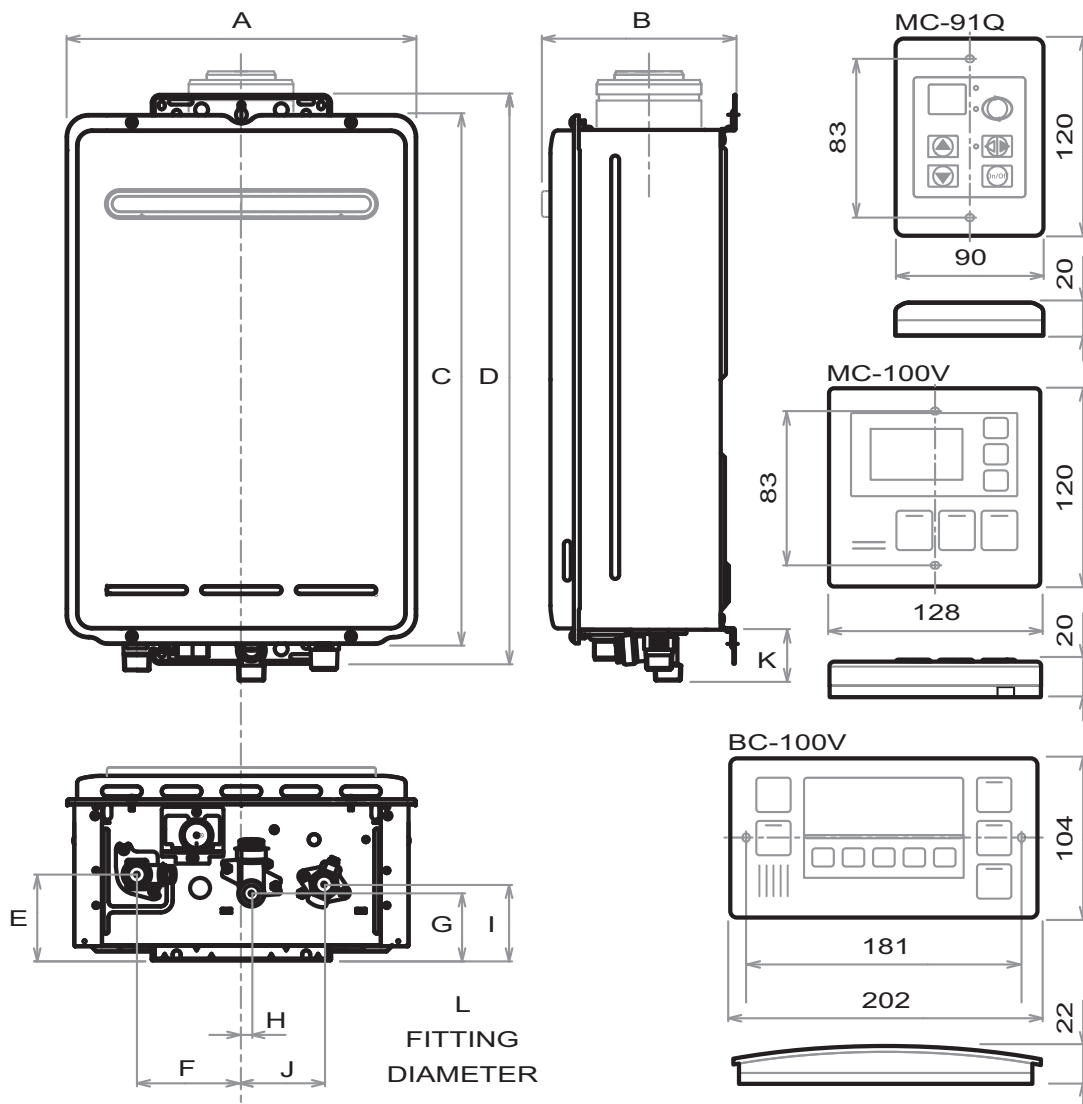

Dim'	Description	REU-V1620WG REU-V1620WB REU-V1620WS REU-V2024WG
A	Width	350
B	Depth	194
C	Height - Unit	530
D	Height - Including Brackets	571
E	Hot Water outlet (from wall)	87
F	Hot Water outlet (from centre)	105
G	Cold Water inlet (from wall)	68
H	Cold Water inlet (from centre)	10
I	Gas Connection (from wall)	77
J	Gas Connection (from centre)	83
	Gas: Length (from base)	40
K	Cold: Length (from base)	50
	Hot: Length (from base)	39
	Gas: Fitting Diameter	20
L	Cold: Fitting Diameter	15
	Hot: Fitting Diameter	15

\* Please note that this measurement is to the left of the centre line.

## 4. Water Controllers



All water controllers must be installed in accordance with the relevant operation/installation instructions supplied with the water heater or controllers.



Care should be taken to ensure power supply to the Infinity is isolated when connecting / disconnecting controller wiring or transponder on wireless controllers. Failure to isolate power supply may result in damage to the appliance PCB.

Care should be taken when closing the Ezi-connect access panel, to ensure internal wiring for controllers is not shortened or crushed.

### Troubleshooting

#### Controller not showing display - (Wired Controllers)

- Check that the correct number and combination of controllers have been installed for the specific model Infinity. Refer to controller compatibility table below.
- Check controller is turned ON.
- Check there is 12VDC power supply available to the controller from the Ezi-connect terminals.
- If there is 12VDC available from the Ezi Connect but no controller display, check wiring between Ezi-connect and controller is sound.
- If there is no power from the Ezi-connect terminals, but the hot water functions correctly, replace PCB.

#### Error Code 12 as soon as hot water tap is turned ON.

- Check 12VDC internal wiring to Ezi-connect terminal is not crushed or shorted.
- Rectify wiring and re-close Ezi-connect cover carefully.

#### Controller not showing display - (Wireless Controllers)

- Ensure transceiver module is mounted in the correct location, as per wireless controller installation instructions.
- Ensure 2 x AA batteries are in good working order and installed with the correct polarity within the wireless controller. (Battery polarity details on rear of wireless controller).
- Ensure distance between wireless controller and transceiver does not exceed 50 metres.
- Ensure channel has been allocated to each wireless controller.
- Ensure wireless controller has been programmed to the transceiver correctly, as per wireless controller installation instructions.

### Controller Compatibility Table

<b>Wireless Only Installation</b>	A maximum of 4 wireless water controllers can be fitted with the following limitation: Only <b>ONE</b> MC-502RC can be set as the Master Controller.
<b>Wired &amp; Wireless Installations</b>	A maximum of 4 water controllers can be fitted. Any combination of deluxe, universal and wireless controllers can be used with the following limitation:  <b>Only <u>ONE</u> master controller can be installed. This can be a MC-100V, a MC-91Q (when programmed as a master controller) or a MC-502RC / MC-503RC water controller.</b>  <b>Up to <u>TWO</u> BC-100V water controllers can be installed.</b>  <b>The <u>FOURTH</u> water controllers in any installation MUST BE a MC-502RC / MC-503RC or a MC91Q.</b>

## PROGRAMMING FOR THE 'UNIVERSAL' WATER CONTROLLER (MC-91Q)



### 1 Are there four water controllers connected?

**IF NO:** (You have three water controllers or fewer), go to Question 2.

**IF YES:** You will need to activate the fourth water controller as follows:

**STEP 1:** For the water controller in the KITCHEN ONLY, press and hold the 'Transfer' and 'On/Off' buttons simultaneously (see Fig. 5) until a 'beep' is heard (approximately 5 seconds).

**STEP 2:** Check that the display on ALL FOUR water controllers is lit and displaying a temperature when 'switched on'. If any ONE of the controller displays two dashes (see Fig. 6) repeat STEP 1.

This completes the activation procedure for the fourth controller, you may ignore Question 2.

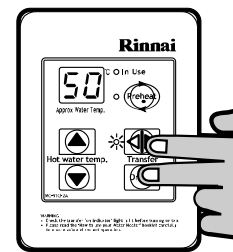

Fig. 5



Fig. 6



### 2 Is the water heater marked to state it delivers water not exceeding 50°C?

**IF YES:** No further action required.

**IF NO:** You will need to program the kitchen controller to enable selection of temperatures higher than 50°C.

**STEP 1:** For the controller in the KITCHEN ONLY, press and hold the 'Transfer' and 'On/Off' buttons simultaneously (Fig. 7) until a 'beep' is heard (approximately 5 seconds).

**STEP 2:** When the controller fitted in the KITCHEN is switched On, it should be possible to select temperatures higher than 50°C. If not, repeat STEP 1.

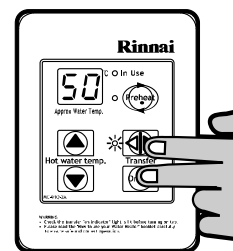

Fig. 7



**If the water controller in the kitchen is replaced, repeat STEP 1 above for the replacement controller.**

**If the water controller in the kitchen is swapped with another controller (for example, the controller fitted in a bathroom), repeat STEP 1 for the controller moved from the kitchen to the bathroom. Then perform STEP 1 for the controller moved from bathroom to the kitchen.**

## 5. Smartstart

At least one temperature controller model MC-91Q must be used in conjunction with the water heater and the Smartstart® system. Alternatively, if water controllers cannot be used a manual activation switch must be used. Water Controllers cannot be used with the 1620WS model.

The installation of the water heater and temperature controllers must be performed in accordance with the installation instructions supplied with the water heater.

The Smartstart® system is designed for domestic installations. However, it may be suitable for certain non domestic installations. See separate service manual for more information.

### Principle of Operation (Fig.2)

The "Smartstart®" system heats the water in the pipework water connected between the water heater and the hot water outlets before any outlets are opened using the 'flow and return' pipework principle. This results in water savings and reduced waiting time for heated water delivery from the outlet when opened.

Traditional 'flow and return' systems usually keep the water in the pipework heated continuously. The Smartstart® system however, only heats the water before the outlet is opened. This results in significant energy savings because water is not heated unnecessarily whilst retaining the benefits of traditional flow and return systems.

A schematic of the Smartstart® system installed in conjunction with a Rinnai continuous flow water heater and temperature controller is shown in Fig.2 below.

If problems are experienced with Smartstart® operation refer to the Smartstart® Service Manual.

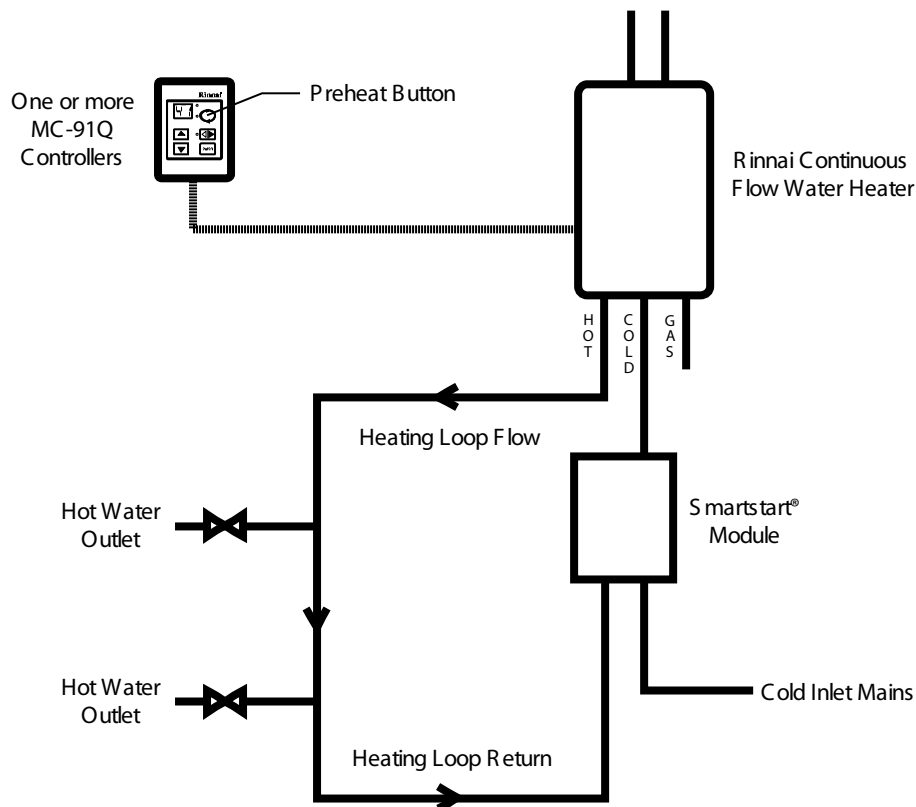
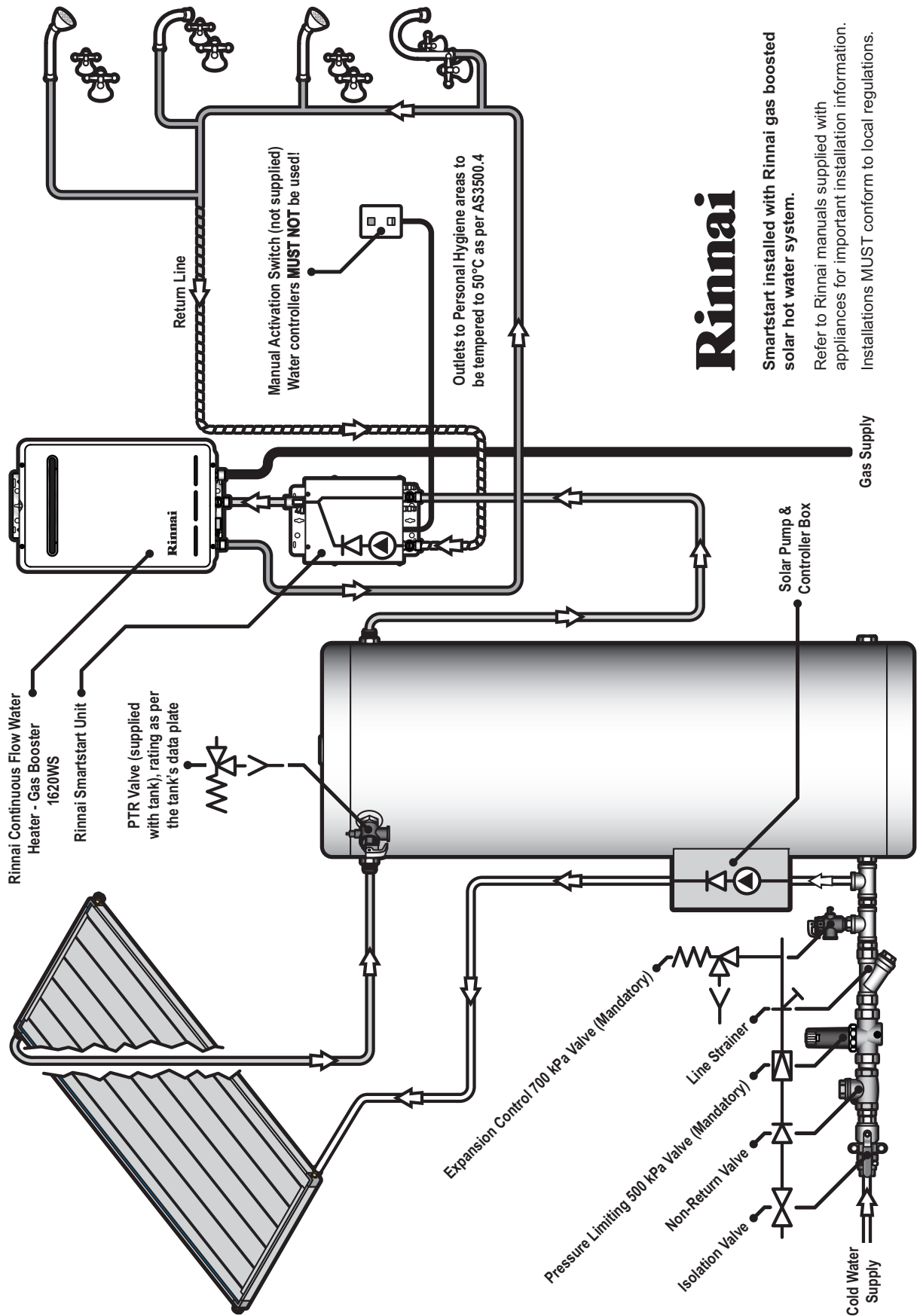

Figure 2 - Non Solar Hot Water Systems

# Principle of Operation - Solar Hot Water Systems Only



# Rinnai

Smartstart installed with Rinnai gas boosted solar hot water system.

Refer to Rinnai manuals supplied with appliances for important installation information. Installations **MUST** conform to local regulations.

Figure 3 - Principle of Operation - Solar Hot Water Systems Only

## 6. Cutaway Diagram

NOTE: This diagram is of a general nature. Some details may be different on some models

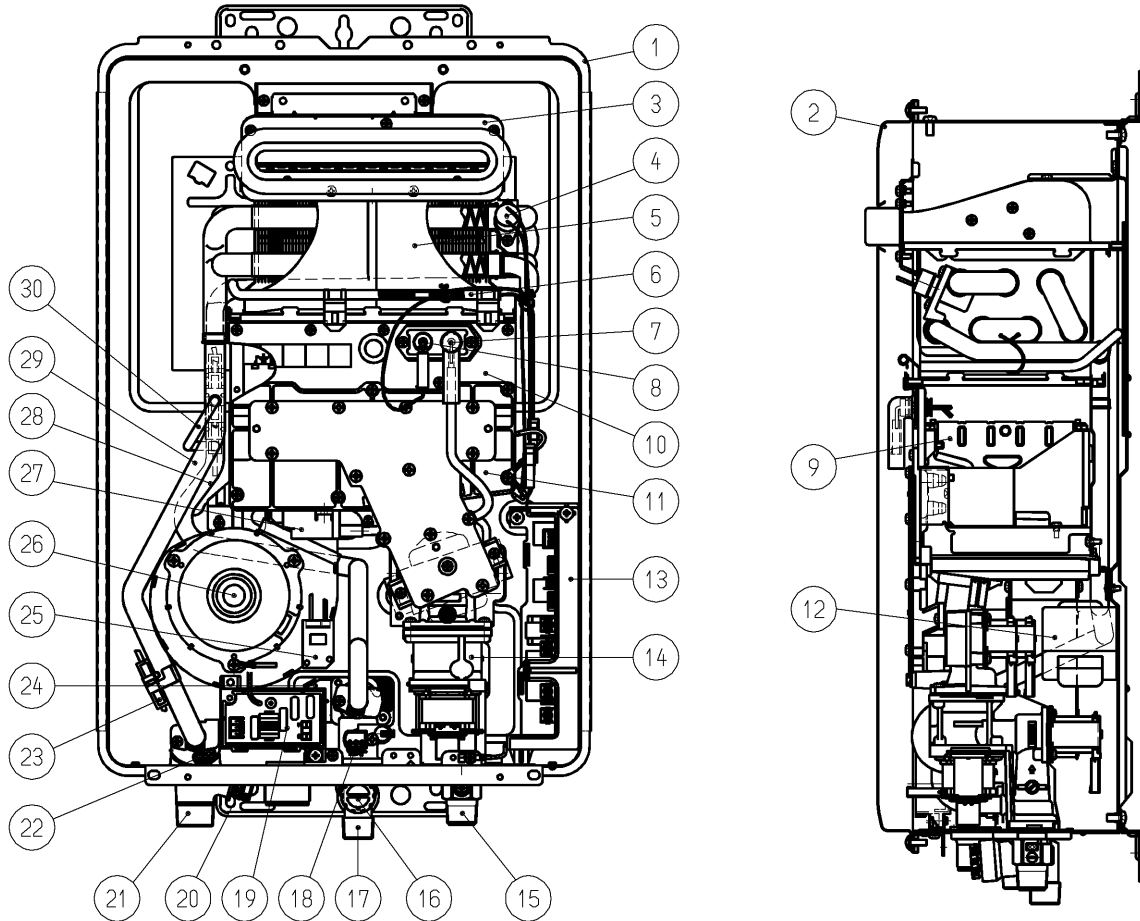

Part No.	Description	Part No.	Description	Part No.	Description
1	Casing Assembly	11	Manifold Assembly	21	Hot Water Outlet
2	Front Panel Assembly	12	Transformer	22	Ongoing Water Thermistor
3	Flue Outlet	13	P.C.B.	23	Anti-Frost Heater
4	Overheat Switch	14	Gas Control Assembly	24	Water Flow Control Device
5	Heat Exchanger	15	Gas Connection	25	Frost Sensing Switch
6	Thermal Fuses	16	Water Filter Assembly	26	Combustion Fan
7	Electrode	17	Water Inlet	27	Igniter
8	Flame Rod	18	Water Flow Sensor	28	Water Connecting Pipe
9	Main Burner	19	Surge Protector	29	Hot Water Connecting Pipe
10	Combustion Chamber Front Plate Assembly	20	Pressure Relief Valve	30	By-pass Pipe

# 7. Operational Flow Chart

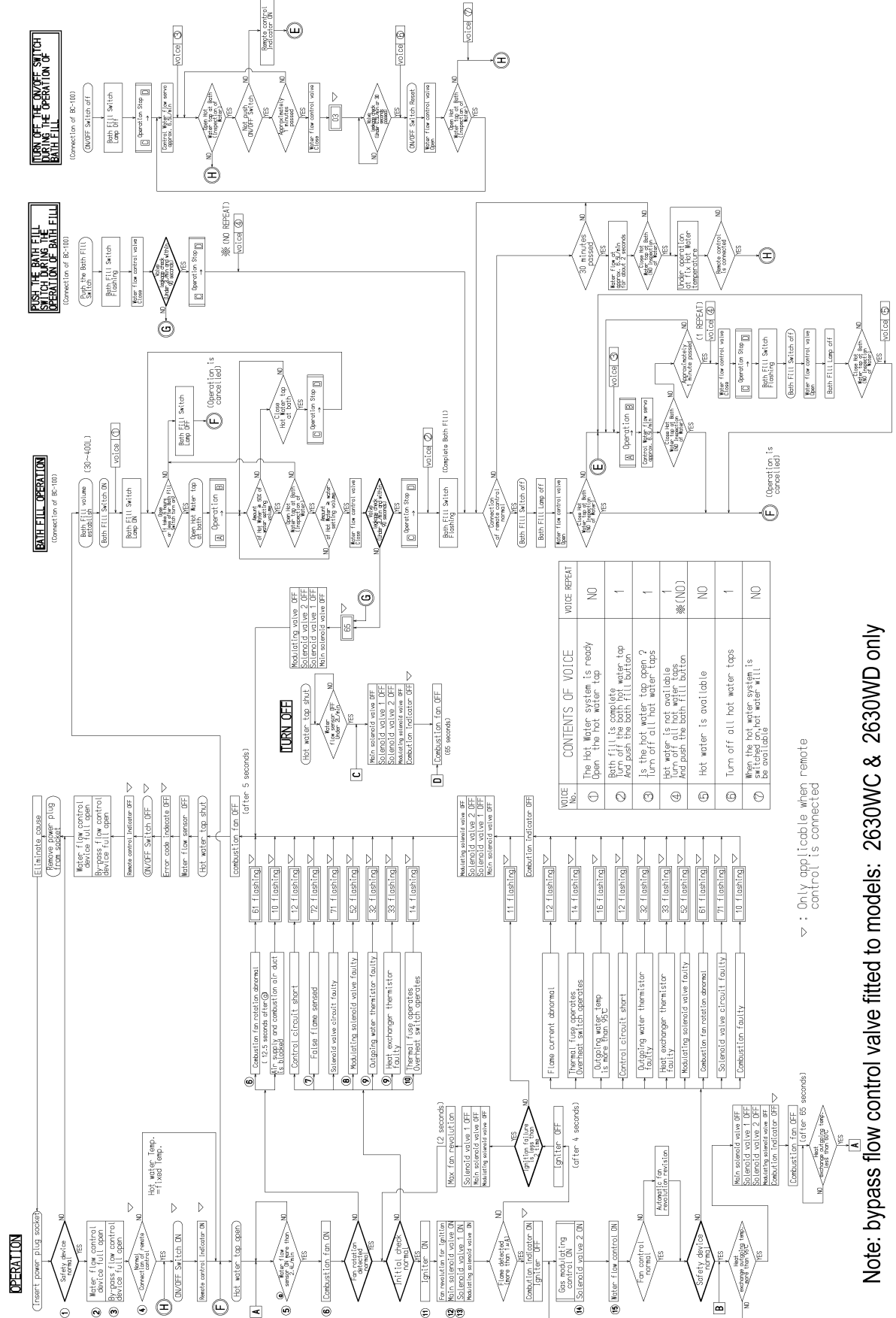

∇ : Only applicable when remote control is connected

**Note:** bypass flow control valve fitted to models: 2630WC & 2630WD only



# 8. Operation Principles

---

## Hot Water Operation

### 1. Ignition

- Activate controllers (if fitted) and open the hot water tap (for full details regarding operation of water controllers refer to the 'Customer Operation and Installation' manual).
- When water flows through the unit, the water flow sensor rotates and sends an electrical 'pulse' signal to the Printed Circuit Board (PCB). This signal is proportional to the water flow rate.
- The PCB sends electrical current to the combustion fan motor causing it to turn. The fan motor sends an electrical pulse signal to the PCB. If fan rotation is OK, the main solenoid and changeover solenoid valves open as required, the spark generator activates and the spark electrode ignites the burner.

### 2. Water Temperature / Flow Control / Volume Control

- The PCB will automatically control operation of the internal components to achieve the programmed temperature. When a high temperature rise is required, the PCB may cause the Water Flow Servo to close partially resulting in a lower flow rate to achieve the programmed temperature. This is a necessary operational feature of the unit.
- When operating in 'Bath Fill' mode, the signal from the water flow sensor is also used by the PCB to compute the volume of water that has been passed through the unit at any instant whilst the bath is filling.

### 3. Shut Down

- When operating in 'Bath Fill' mode, the PCB causes the Water Flow Servo to close when the programmed Bath Fill volume has passed through the unit. Alternatively, flow is stopped when the user closes the hot water tap.
- When water flow stops, the water flow sensor stops rotating and the pulse signal to the PCB stops. The PCB then causes the main solenoid and solenoid valves to close and the burner is extinguished. The combustion fan will continue to operate for some time to purge the combustion chamber.

# 9. Main Components

---

## 1) Printed Circuit Board (PCB)

- The Printed Circuit Board controls all operational functions including Air Supply Control, Gas Control, Water Flow Measurement, Water Flow Control, Combustion System and all sensors and safety devices.

## 2) Gas Flow Control

- During normal operation, the PCB keeps the main solenoid valve open whilst there is flow through the unit and the burner needs to be lit.
- Gas flow rate is controlled by the modulating valve assembly and three changeover solenoid valves to always ensure constant outlet water temperature, regardless of flow rate or incoming water temperature.
- The modulating valve is electronically controlled by the PCB using signals from the water flow sensor, water flow control device, water temperature thermistors and combustion fan speed sensor. The modulating valve directs gas to the three changeover solenoid valves.
- The changeover solenoid valves direct gas to each of the two burner banks independently. Any one or two or both of the solenoid valves may be open during operation.
- Gas flow is modulated by a combination of the modulating valve and changeover solenoid positions.
- The maximum gas rate is predetermined and the appliance cannot be overloaded when correctly installed.

## 3) Water Flow Control

- Water flow is detected by a turbine coupled to a magnetic pulse generating device. The magnetic pulses are detected and counted by the PCB. The PCB calculates the exact water flow from the frequency of pulses generated by the turbine, as well as the volume of water that has passed through the unit at any instant during 'Bath fill' operation.
- Water flow control is achieved through the use of servo driven water flow and fixed bypass valves. (Note: only some models have a bypass valve fitted). Both servo motors are controlled by the PCB. The 'Water Flow Valve' restricts the flow of water into the heat exchanger assembly if the programmed temperature cannot be achieved. During normal operation, cold water from the inlet valve is mixed with hot water from the heat exchanger outlet.
- For models fitted with a 'Bypass' valve, it mixes the correct proportion of cold and hot water to ensure accurate hot water delivery temperature over the available range of flow rates. The water flow and bypass valves are a combined assembly on the cold water inlet of the appliance.

## 4) Air Supply Control

- Air for combustion is supplied by a centrifugal fan driven by a variable speed DC motor. The voltage to the motor is determined by the PCB based on water flow, delivered water temperature and programmed water temperature. The actual fan speed is monitored by a magnetic pulse counter. This counter emits a signal to the PCB. From the voltage supplied to the DC motor and the fan speed signal, the PCB determines whether an error condition exists with the fan.

## 5) Combustion System

The combustion chamber is housed within the heat exchanger assembly and comprises:

- A multi chamber aluminium alloy manifold with a multiple integral injectors. Gas flow to each chamber is controlled by an electronic solenoid valve (refer 'Gas Flow Control' above).
- A burner assembly comprising multiple identical modular stainless steel bunsen burners secured by an aluminised steel framework. The manifold is attached to the front of the burner module. Each bunsen burner is supplied by two injectors.
- A combustion chamber. Integrated into the combustion chamber front panel are the flame rod and ignition electrode(s).

# 10. Time Charts

## Normal Combustion

Note: By pass control device fitted to model 2630 only.

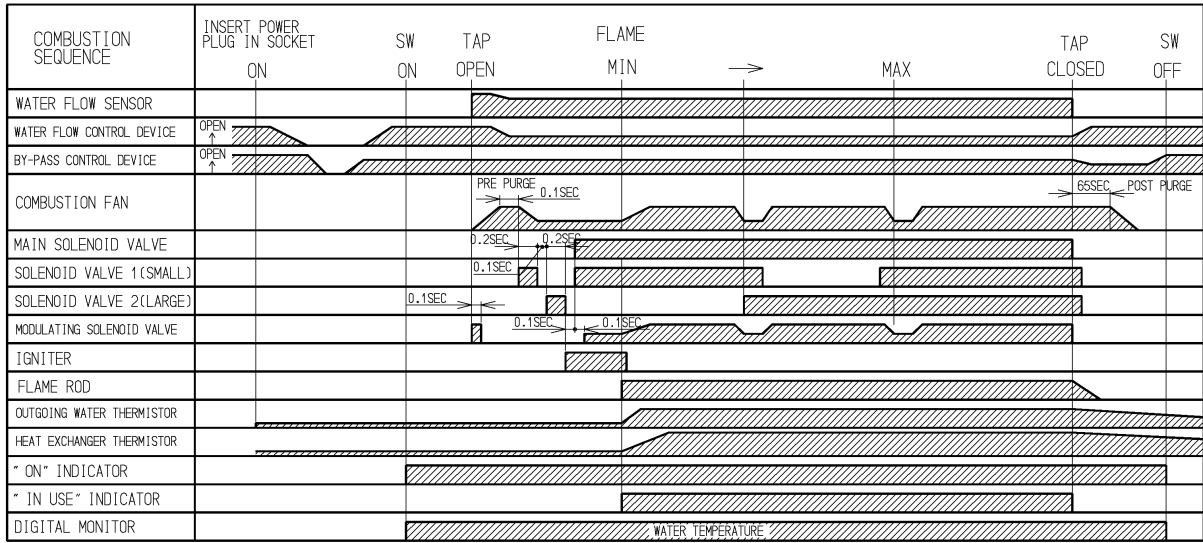

## Mis-Ignition / Flame Failure

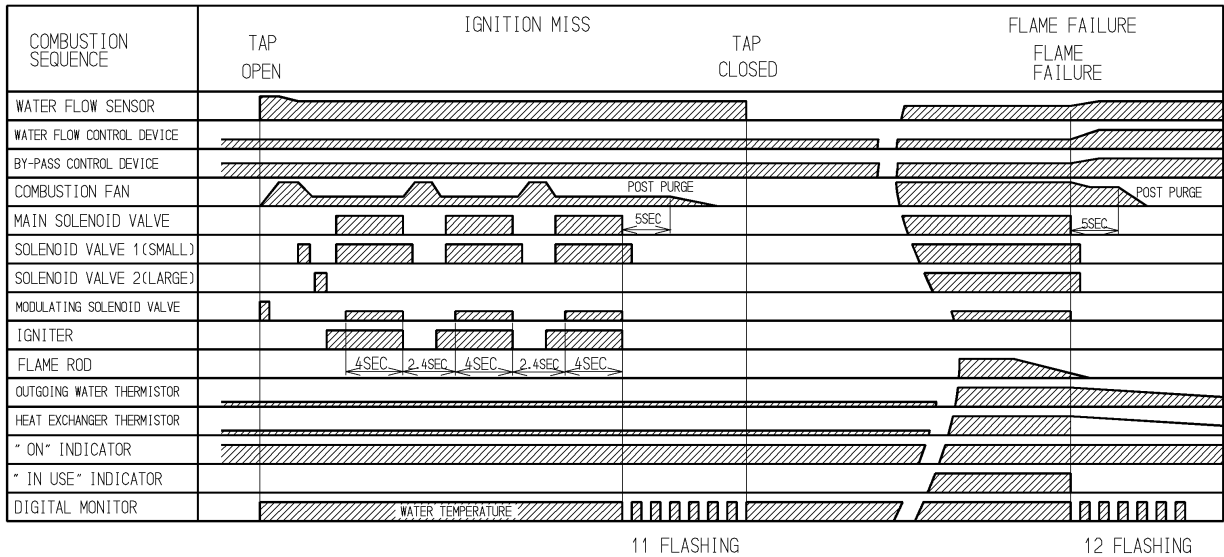

## Abnormal Pre-Purge (Air Supply/Exhaust Blockage)

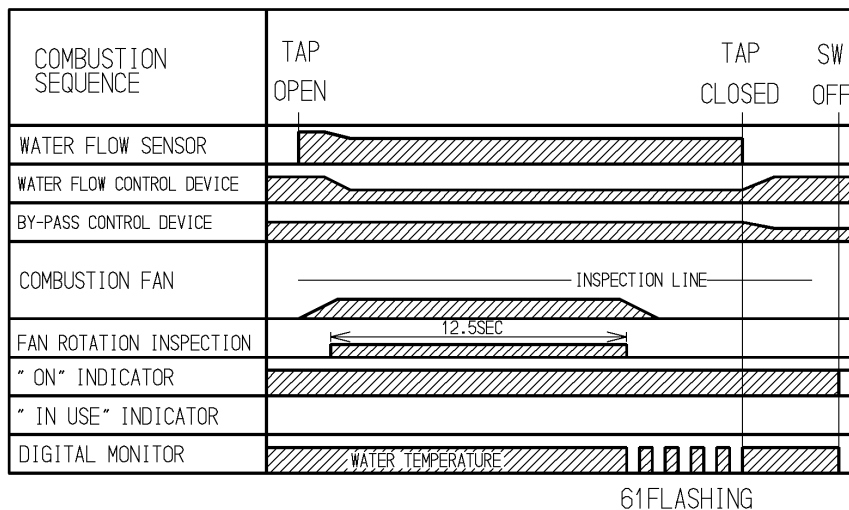

# 11. Wiring Diagram

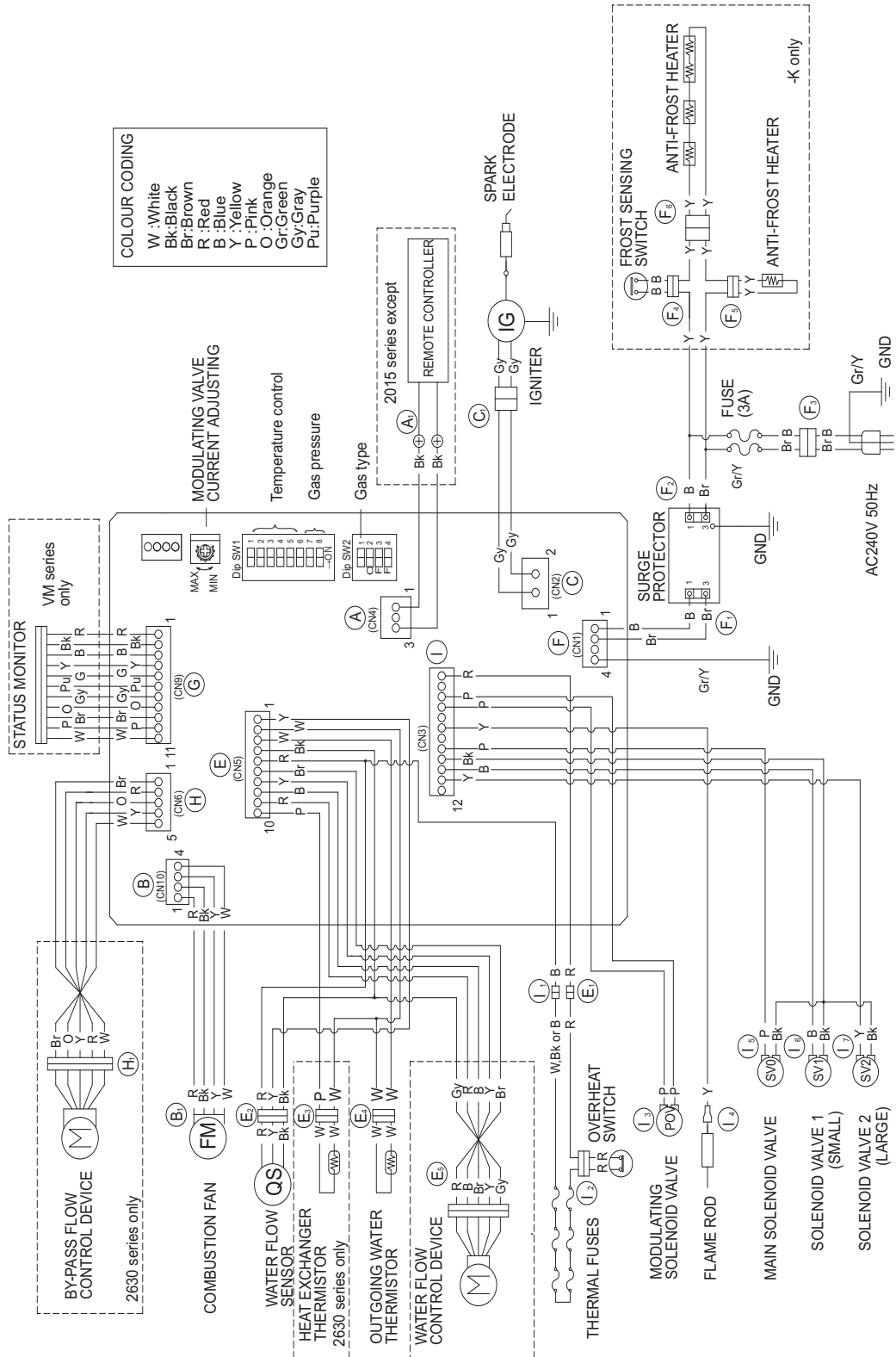

# DIAGNOSTIC POINTS TABLE

## Wiring Diagram Measurement Point

FLOW CHART No.	COMPONENT	MEASUREMENT POINT		NORMAL VALUE	NOTE
		CN	WIRE COLOUR		
①	SURGE PROTECTOR	F <sub>3</sub>	B-Br	AC207~264V	
②	WATER FLOW CONTROL DEVICE	E <sub>5</sub>	R-B	±DC11~13V (ONLY WHEN OPERATING)	OPERATE ELECTRICITY
③			Y-Gy	BELOW DC1V(LIMITER ON)	FULL OPEN POSITION
④			Br-Gy GND	BELOW DC1V(LIMITER ON) DC4~6V(LIMITER OFF)	FULL CLOSE POSITION
⑤	BY-PASS FLOW CONTROL DEVICE	H <sub>1</sub>	Br-W O-W Y-W R-W GND	DC12V(OPERATING DC2~6V)  15~35Ω	
⑥	REMOTE CONTROL	A <sub>1</sub>	Bk-Bk	DC11~13V	
⑦	WATER FLOW SENSOR	E <sub>2</sub>	R-Bk	DC11~13V	ON2.4L/MIN (33Hz) OVER 1980PULSE/MIN OFF1.7 L /MIN (23Hz) BELOW 1380PULSE/MIN
⑧			Y-Bk GND	DC4~7V(PULSE 20~320Hz)	
⑨	COMBUSTION FAN	B <sub>1</sub>	R-Bk	DC15~46V	
⑩			Y-Bk	DC11~13V	
⑪			W-Bk GND	DC5~10V (20~400Hz)	
⑫	FLAME ROD	I <sub>4</sub>	Y-FLAME ROD	OVER DC1μA	FLAME CONDITION
⑬	MODULATING SOLENOID VALVE	I <sub>3</sub>	P-P	DC2~15V 65~85Ω	
⑭	HEAT EXCHANGER THERMISTOR	E <sub>3</sub>	W-W	15°C... 11.4~14.0kΩ 30°C... 6.4~ 7.8kΩ 45°C... 3.6~ 4.5kΩ 60°C... 2.2~ 2.7kΩ 105°C... 0.6~ 0.8kΩ	
	OUTGOING WATER THERMISTOR	E <sub>4</sub>			
⑮	THERMAL FUSES	I <sub>1</sub> E <sub>1</sub>	W-R (16 series) Bk-R (20 series) B-R (24/26 series)	BELOW 1Ω	
⑯	IGNITER	C <sub>1</sub>	Gy-Gy	AC207~264V	
⑰	MAIN SOLENOID VALVE	I <sub>5</sub>	P-Bk	DC11~13V 37~43Ω	
⑱	SOLENOID VALVE 1 (SMALL)	I <sub>6</sub>	B-Bk	DC11~13V 35~41Ω	
⑲	SOLENOID VALVE 2 (LARGE)	I <sub>7</sub>	Y-Bk	DC11~13V 37~43Ω	

## 12. Dip Switch Settings

Contact Rinnai for Dip Switch Settings.

# 13. Fault Finding



If there is a fault with the appliance, and controllers are installed, a numerical fault code may appear on the digital display controller. If controllers are not installed, one may be fitted to find out the fault code. Fault finding without controllers (and thus fault codes) is possible but more time consuming.

To diagnose and rectify faults, the **Fault Finding Table** is used as illustrated below:

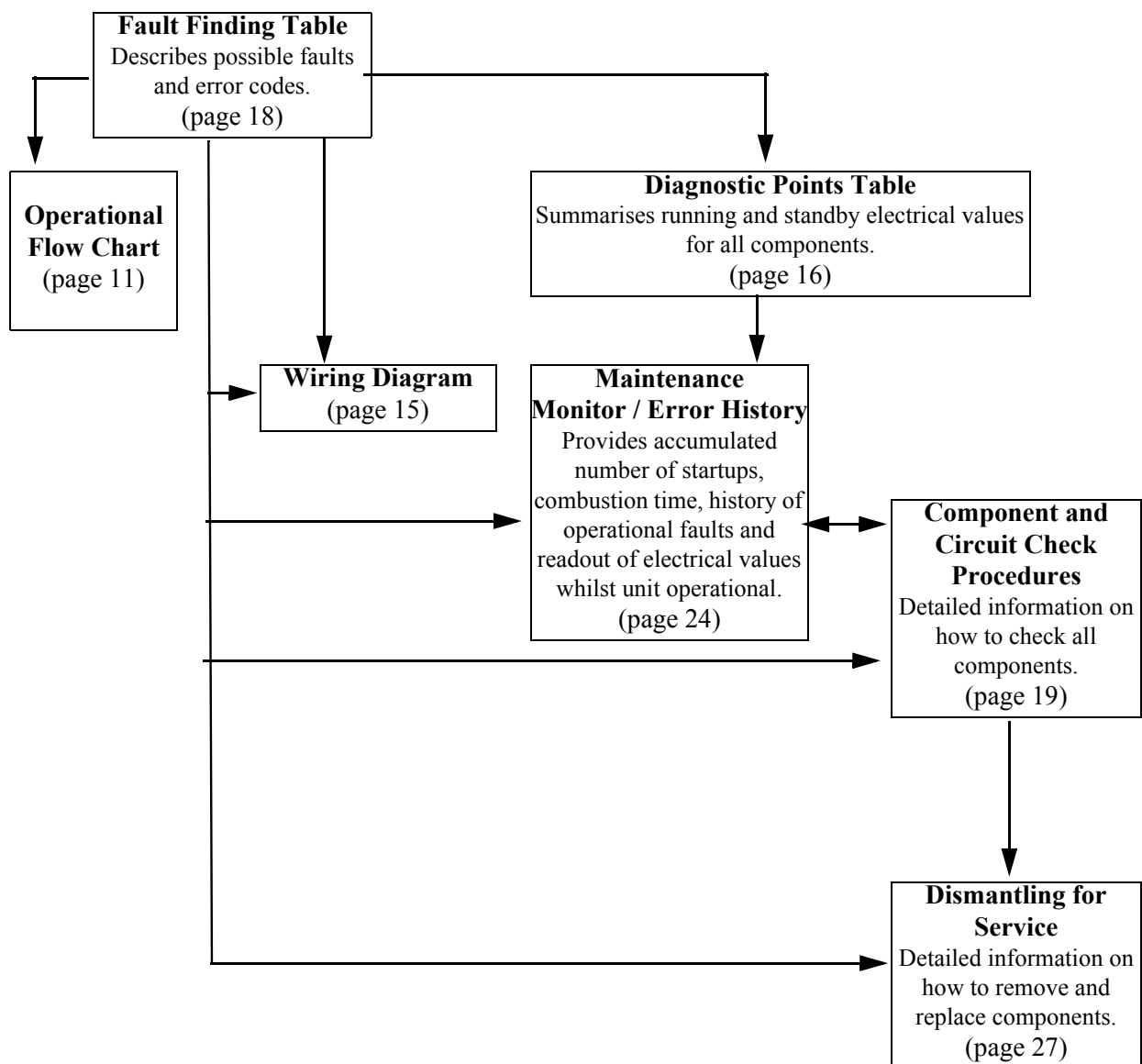

## Fault Finding Table

Code on Controller	Fault	Action
03	Power interruption during Bathfill. Water will not flow when power restored.	1. Turn off all hot water taps. 1. Press the ON/OFF button on a controller twice.
10	Combustion fan current too high. Unit operates, then stops.	1. Check blockage of air intake/flue outlet. 2. Check combustion fan.
11	No ignition. Unit stops without flame igniting	1. Check gas supply 2. Check sparker unit 3. Check gas valves
12	Flame Failure / Earth Leakage	1. Check gas supply 2. Check flame rod 3. Check earth wire lead 4. Check remote control
14	Thermal fuse and/or overheat switch activated. Unit operates, then stops.	1. Check thermal fuse 2. Check overheat switch IMPORTANT- If thermal fuse or overheat switch were faulty : a. Check heater for damage b. Confirm "Gas Type" and "Combustion" dip switch settings c. Confirm test point pressures .
16	Over temperature warning. Unit operates, then stops.	1. Confirm "Gas Type" and "Combustion" dip switch settings 2. Confirm test point pressure 3. Check gas valves 4. Check water flow sensor 5. Check water flow servo 6. Check heat exchanger outlet temperature thermistor 7. Check hot water outlet temperature thermistor
32	Outlet water thermistor flow	Check hot water outlet thermistor
33	Heat exchanger thermistor error	Check heat exchanger thermistor
52	Modulating solenoid valve fault. Unit stops without flame ignition.	Check modulating solenoid valve
61	Combustion fan rotation error	Check combustion fan
65	Water flow control device error. Water flow is not controlled. Water temperature too low.	Check water flow servo
71	Solenoid valve circuit error. Unit does not operate.	Check gas valves
72	Flame rod circuit error. Unit does not operate.	Check flame rod
-	Appliance does not operate at all. No display on the water controllers (if fitted).	1. Check power cord plugged in and supply turned on. 2. Check power supply voltage. 3. Check electrical fuse. 4. Check transformer. 5. Check gas valves 6. Check sparker unit. 7. Check earth leads and connections. 8. Check for short circuits. 9. Check water controller(s) - if fitted.
-	No combustion despite remote control indicating that combustion is occurring - if water controller(s) fitted.	1. Check water flow sensor. 2. Check flame rod. 3. Check heat exchanger outlet thermistor. 4. Check hot water outlet thermistor. 5. Check combustion fan. 6. Check the sparker unit. 7. Check gas valves. 8. Check thermal fuse. 9. Check overheat switch. IMPORTANT - If thermal fuse or overheat switch were faulty: a) check heater for damage; b) confirm "Gas Type" and "Combustion" dip switch settings; c) confirm test point pressure.
-	Combustion stops during operation.	1. Check gas supply 2. Check flame rod 3. Check earth leads and connections.
-	Cannot adjust the hot water temperature via the controller(s) - only if water controller(s) fitted.	1. Check hot water outlet thermistor. 2. Check heat exchanger outlet thermistor. 3. Check gas valves 4. Check water flow servo. 5. Check bypass servo.
-	Anti-frost heater does not operate.	1. Check anti-frost heater components 2. Check frost sensing switch

# 14. Component and Circuit Checks



## 1. Combustion Fan Circuit

- a) Check the Motor
- b) Check the combustion fan if the error indicator displays “61”.
- c) Measure resistance between Black-Red of the PCB connector (**B<sub>1</sub>**).

*Normal:* DC15~46V (when fan ON)

DC0V (when fan OFF)

If normal proceed to check the rotation sensor

**Faulty:** Replace PCB

Check for the Fan Rotation Sensor

- a) Measure resistance between Black-Yellow of connector (**B<sub>1</sub>**).

*Normal:* DC11~13V

If normal proceed to b.).

**Faulty:** Replace PCB.

- b) Measure resistance between Black-White of connector (**B<sub>1</sub>**).

*Normal:* DC5~10V (20~400Hz)

If normal proceed to Sparker Circuit 2.

**Faulty:** Replace Combustion Fan.

## 2. Igniter Circuit

- a) Measure resistance between Grey-Grey of connector (**C<sub>1</sub>**).

*Normal:* AC207~264V

If Normal proceed to b.).

**Faulty:** Replace PCB.

- b) Disconnect connector (**C<sub>1</sub>**) and measure resistance between both terminals of the sparker.

*Normal:* 1MΩ

If not sparking, adjust or replace ignition plug.

**Faulty:** Replace Sparker.

## 3. Main Solenoid Valve (SV<sub>0</sub>)

Check the main solenoid if error indicator “11” is displayed.

- a) Measure resistance between Pink-Black wires of main solenoid connector (**I<sub>5</sub>**)

*Normal:* DC11~13V

If normal, proceed to b.).

**Faulty:** Replace PCB

- b) Measure resistance between Main Solenoid connectors.

*Normal:* 37~43Ω

If normal, proceed to Solenoid Valve **SV<sub>1</sub>** **Faulty:** Replace Main Solenoid.



#### 4. Solenoid Valve 1 (Small) (SV<sub>1</sub>)

Check Solenoid valve 1 if error indicator “11” is displayed.

- a) Measure resistance between Blue-Black wires of main solenoid connector (I<sub>6</sub>)

*Normal:* DC11~13V

If normal, proceed to b.

**Faulty:** Replace PCB.

- b) Measure resistance between Solenoid 1 connectors.

*Normal:* 35~41Ω

If normal, proceed to Solenoid Valve 2 (SV<sub>2</sub>) Circuit

**Faulty:** Replace Solenoid 1

#### 5. Solenoid Valve 2 (Large) (SV<sub>2</sub>)

- a) Measure voltage between black-yellow and black wires of solenoid valve 2 connector (I<sub>7</sub>)

*Normal:* DC11~13V

If normal, proceed to b.).

**Faulty:** Replace PCB.

- b) Measure resistance between Solenoid Valve 2 connectors.

*Normal:* 37~43Ω

If normal, proceed to Modulating Valve Circuit.

**Faulty:** Replace Solenoid Valve 2.

#### 6. Modulating Solenoid Valve (POV)

- a) Measure voltage between pink-pink wires of the modulating solenoid valve.(I<sub>3</sub>).

*Normal:* DC2.0~15V

If normal, proceed to c.).

**Faulty:** Replace PCB.

- b) Measure resistance between modulating solenoid valve connectors.

*Normal:* 65~85Ω

If normal, proceed to b.).

**Faulty:** Replace PCB.

- c) Check the gas burner pressure changes when set temperature on the water control changes from 37°C to 55°C.

*Normal:* Burner gas pressure changes. Go to Water Flow Servo Circuit.

**Faulty:** Burner gas pressure does not change. Replace Modulating Valve.

## 7. Flame Rod Circuit

Operate appliance and check flame rod (**I<sub>4</sub>**)

Check Dc current flow between yellow flame rod wire and earth is over DC1 $\mu$ A

Disconnect flame rod terminal (**I<sub>4</sub>**), and re-operate appliance.

“72” indicated:- Proceed to **c**).

“72” is not indicated:- check for electrical leaks from the flame rod circuit.

Measure voltage between flame rod terminal (**I<sub>4</sub>**) and appliance earth.

*Normal:* >1M $\Omega$

If normal, Check all power inputs into PCB. If power inputs okay replace PCB.

If resistance abnormal replace flame rod.

**a)** Remove the Flame Rod terminal (**I<sub>4</sub>**) repeat appliance operation procedure, if “72” is displayed again check the Hot water outlet thermistor.

If “72” is not displayed check current leakage from the Flame Rod.

**b)** Measure voltage between body earth and Flame Rod terminal (**I<sub>4</sub>**).

*Normal:* voltage AC100~160V

If normal, check all power inputs into PCB. If power inputs okay replace PCB.

*Faulty:* Replace Flame Rod.

**c)** Check if the Flame Rod is securely fitted.

*Normal:* Check all power inputs into PCB. If power inputs okay replace PCB.

*Faulty:* Adjust the fitting of the Flame Rod.

Check all appliance earth connections are clean and secure.

## 8. Overheat Switch and Thermal Fuse Circuit

1. Disconnect overheat switch terminals (**G<sub>2</sub>**) and measure resistance between overheat switch terminals (**G<sub>2</sub>**)

Normal: < 1  $\Omega$

If normal reconnect overheat switch terminals (**G<sub>2</sub>**) and proceed to step 2.

*Faulty:* Replace overheat switch.

2. Disconnect relay connectors **G<sub>1</sub>** and **E<sub>3</sub>** measure resistance between the white and red wires.

(16 Series) White-Red

(20 Series) Black-Red

(24/26 Series) Blue-Red

Normal: < 1  $\Omega$

If not normal replace thermal fuse.

If normal replace PCB

**Note: If thermal fuse or overheat switch were faulty:**

a) Check heater for damage

b) Confirm gas type and combustion dipswitch settings

c) Confirm test point pressure.

## 9. Water Flow Sensor

a) Measure voltage between Red-Black of relay connector (**E<sub>2</sub>**).

*Normal:* DC 11~13V

If normal, proceed to b).

**Faulty:** Replace PCB.

b) Measure voltage between Yellow-Black of relay connector (**E<sub>2</sub>**).

*Normal:* DC 4 ~ 7 V

If normal, proceed to 2.

**Faulty:** Replace water flow sensor.

*Note:* For controller readout of water flow whilst operational refer maintenance monitor.  
(Chapter 15) No. 1.

## 10. Water Flow Control Device Circuit

a) Disconnect relay connector (**E<sub>5</sub>**), and measure voltage between Red (+) and Black (-) on PCB unit side (while operating).

*Normal:* DC11-13V

If normal: proceed to **b).**

**Faulty:** Replace PCB unit.

b) Measure resistance between Yellow and Grey with relay connector (**E<sub>2</sub>**) connected.

*Normal:* DC4~6V (Pulse 20~320Hz)

**Faulty:** Replace Water Flow Servo. If normal proceed to **c).**

c) Measure voltage between Brown and Grey with relay connector (**G<sub>1</sub>**) connected.

*Normal:* DC4~6V

**Faulty:** Replace Water Flow Servo.

## 11. Thermistor Circuit

Check Thermistor if error code “32” is displayed.

Disconnect relay connector (**E<sub>4</sub>**) and/or (**E<sub>3</sub>**) and measure resistance White -White.

*When disconnected:* resistance >1M $\Omega$

*When short circuit:* resistance < 1  $\Omega$

*Operating:* Check Heat exchanger outlet thermistor

Resistance matches table below.

**Faulty:** Replace hot water outlet thermistor.

*Normal*

Temperature	15°C	30°C	45°C	60°C	105°C
Resistance	11.4~14 k $\Omega$	6.4~7.8 k $\Omega$	3.6~4.5 k $\Omega$	2.2~2.7 k $\Omega$	0.6~0.8 k $\Omega$

If normal proceed to Flame Rod circuit.

**Faulty:** Replace Thermistor.

*Note:* For controller readout of thermistor temperature whilst operational refer maintenance monitor.

## 12. Surge Protector (**F<sub>1</sub>**)

a) Check the electrical fuses between **F<sub>2</sub>** and **F<sub>3</sub>**. Normal resistance across fuse < 1  $\Omega$ . If blown, replace with fuses of the correct rating (240V, 3A). If okay, go to **b).**

b) Check supply voltage at **F<sub>2</sub>**. Voltage between blue and brown wires 207 - 264 V. If supply voltage incorrect check power supply to appliance. If okay go to **c).**

c) Check voltage at **F<sub>1</sub>**. Voltage between blue and brown wires 207 - 264V.

If voltage is zero repeat **a).** If fuses are okay replace Surge Protector.

### 13. Anti-frost Heater Circuit

a) Disconnect relay connectors (**F<sub>5</sub>**) and measure resistance between yellow wires on the inlet valve frost heater at the frost heater side.

*Normal:* 53Ω

If normal, proceed to b).

**Faulty:** Replace Valve Heater.

b) Disconnect relay connector (**F<sub>6</sub>**) and measure resistance between the yellow wires on the pipe frost heater at the frost heat side.

*Normal:* 618 Ω

**Faulty:** Replace Anti-frost Heater.

### 14. Frost Sensing Switch

Disconnect relay connector (**F<sub>4</sub>**) and measure resistance between Blue-Blue.

*At room temperature resistance should be > 1 MΩ*

Cool switch to below 2° C then measure resistance.

Resistance should be < 1MΩ

**Faulty:** Replace Frost Sensing Switch.

# 17. Maintenance Monitor / Error History

## Wireless Controllers



### Maintenance Function - Wireless Controller Transceiver

- 1.) Press maintenance button once.
- 2.) Temperature light (orange) will illuminate & the Led display will show current water temperature in heat exchanger.
- 3.) Press maintenance button again.  
'Volume' light - (orange) will illuminate. Led display to show l/min water flow through the Infinity.
- 4.) Press maintenance button again and the previous 10 error codes will be displayed.

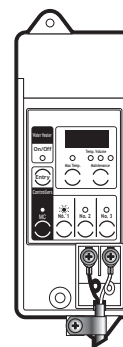

First number shown on Led display will be 1 - followed by error code then 2 and the error code.  
If error code reads — —, it means there was no error recorded.  
Press maintenance button again to return to transceiver to normal mode.

This feature is available where the appliances are connected with a deluxe controller This will enable service personnel to locate the maintenance history and faulty components, with the appliance in operation.

**NB. When the maintenance information, error history is shown, use only one controller. If two or more water controllers are used at the same time, it may not operate correctly.**

### To display Maintenance Information

1. With the controller in the "OFF" position press the Water Temperature "DOWN" (Cooler) button while holding the "ON/OFF" button to activate the maintenance monitor. Press the "ON/OFF" button a second time to set the controller in the "ON" mode. This feature can now be used with the appliance in operation.
2. The maintenance number will be shown in the Water Temperature display.
3. Data will be shown in the Clock display.
4. To select the required maintenance number, press the Water Temperature "UP" and "DOWN" buttons.

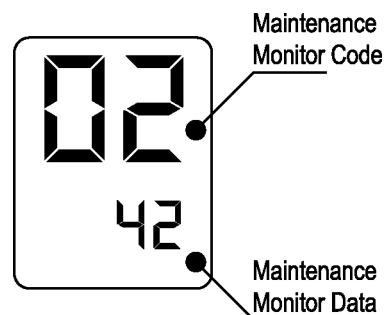

Display Monitor Contents			
No.	Contents	Units	Data Range
01	Water flow sensor recognition flow (Example 123 = 12.3L/min).	0.1L/min	0~400
02	Hot water Outlet thermistor temperature (Example 20 = 20°C)	°C	0~999
03	Hot water combustion time (Example 6 = 600 hours)	100 hours	000~999
04	Hot water operation frequency (Example 6 = 600 Operations)	100	0~999
05	Hot water fan frequency	Hz pulses/sec	0~999 * <b>Note 1</b>

**\*Note 1 Fan Frequency rpm Conversion**

$$(rpm) = (Hz) \times 15$$

06	Water control connection	none	0 or 1 * <b>Note 2</b>
----	--------------------------	------	------------------------

**\*Note 2 Water Control Connections**

Bathroom Controller		Controls connected	Display
Additional controller	Kitchen controller	No	"0"
"0"	"1"	Yes	"1"

07	Water flow servo present recognising positioning	None	0~2 * <b>Note 3</b>
----	--------------------------------------------------	------	---------------------

**\*Note 3 Water Flow Servo Positioning**

Servo Position	Open	Centre	Closed
Display	"1"	"0"	"2"

08	Inlet water temperature (PCB recognition value) (Example 25 = 25 °C)	°C	0~999
09	Hot water fan current flow value (Example 6 x 10 = 60 mA)	10 mA	0~999
10	Bath fill amount (this counts the litres during bath fill operation).	Litres	0~999
11	Heat exchanger exit thermistor temperature (Example 55 = 55°C)	°C	0~999
12	Bypass servo present recognition positioning (Example 0 = Closed 250 = Half open 500 = Open)	Degrees	0~500

**To return to normal operation**

- Press the ON/OFF button again while holding down the Water Temperature "DOWN" (Cooler) button.

## Error History

### To Display Error Memory (History)

*(This feature will show the last 10 faults in sequence)*

1. Turn off at the ON/OFF button. (This can be done during operation)
2. Press the ON/OFF button while holding the Water Temperature "UP" (Hotter) button.
  - The Sequence will be shown in the Water Temperature display.
  - Error Code will be shown in the Clock display. (See service Manual for error codes).
  - Where there are less than a total of 9 errors, "FFF" or " - - " will be displayed in the Clock display.

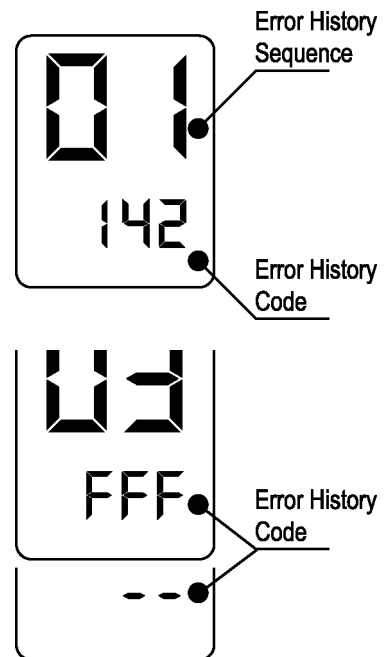

### To return to normal operation.

- Press the ON/OFF button again while holding the Water Temperature "UP" (Hotter) button.
- This feature will automatically shut down after 3 minutes.

## 18. Dismantling for Service

---



240 Volt potential exposure. Isolate the appliance and reconfirm with a neon screwdriver or multimeter.

**NOTE:** As this manual covers a wide range of models, some details of the dismantling procedure may be slightly different to those depicted in this manual.

Item	Page
1. Removal of the Front Panel . . . . .	28
2. Removal of the PCB Unit . . . . .	28
3. Removal of the Water Flow Sensor, Servo and Bypass Servo . . . . .	28
4. Removal of the Bypass Servo . . . . .	29
5. Removal of Transformer . . . . .	29
6. Removal of Sparker . . . . .	29
7. Removal of the Manifold and Burner unit . . . . .	29
8. Removal of the Gas Control . . . . .	30
9. Removal of Flame rod and spark plug . . . . .	31
10. Removal of Outgoing Water Thermistor . . . . .	31
11. Removal of Heat Exchanger Thermistor . . . . .	31
12. Removal of Bypass Servo . . . . .	32
13. Removal of Anti Frost Switch . . . . .	32
14. Removal of Anti Frost heater . . . . .	33
15. Removal of the Fan Motor . . . . .	33
16. Removal of Heat Exchanger . . . . .	34
17. Removal of Thermal Fuse . . . . .	35

Unless otherwise stated, re-assembly is the reverse of dismantling.



## IMPORTANT

For some areas of dismantling you may need to isolate any or all of the following:

- \* Isolate gas supply.
- \* Disconnect electrical supply from wall socket.
- \* Isolate water supply.
- \* Drain **all** water from appliance.

### 1) Removal of the Front Panel

- a. Remove four (4) screws.



### 2) Removal of the PCB Unit

- a. Remove the front panel. (Refer Item 1.)
- b. Remove two (2) PCB unit fixing screws and pull out forward.



### 3) Removal of the Water Flow Sensor, Servo and Bypass Servo

- a. Remove the front panel. (Refer Item 1.)
- b. Remove two (2) screws and locking plates located on the water supply pipe and bypass pipe. Pull bypass pipe and water supply pipe forward to clear servo valves. Ensure O-rings are not lost or damaged.

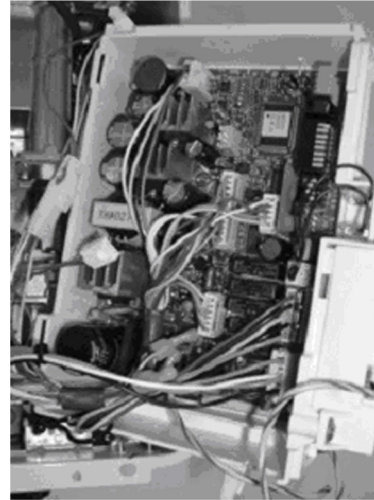

### 4) Removal of the Bypass Servo (2630 ONLY)

- a. Remove two (2) screws from the water flow servo body, and pull the bypass servo out forwards. Ensure O-rings are not lost or damaged.



## 5) Removal of Transformer

- a. Remove PCB (Refer to 2)
- b. Remove 100 V harness and 2-pin connection

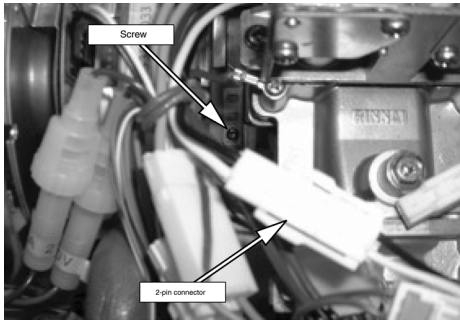

### c. Removal Transformer

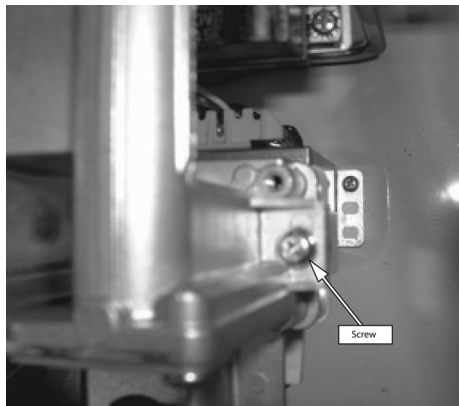

## 6) Removal of Sparker

- a. Remove sparker
- b. Remove 3 pin connector
- c. Remove high tension cord

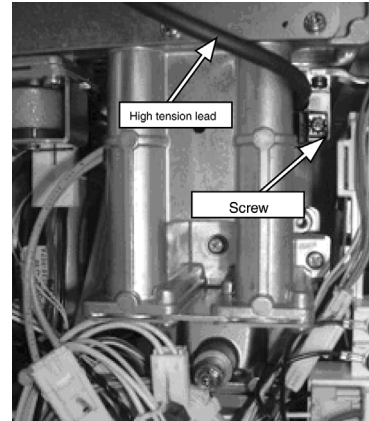

## 7) Removal of the Manifold and Burner unit

- a. Remove high tension cord and flame rod.
- b. Remove 2 pin connection of the solenoid valve
- c. Remove manifold.

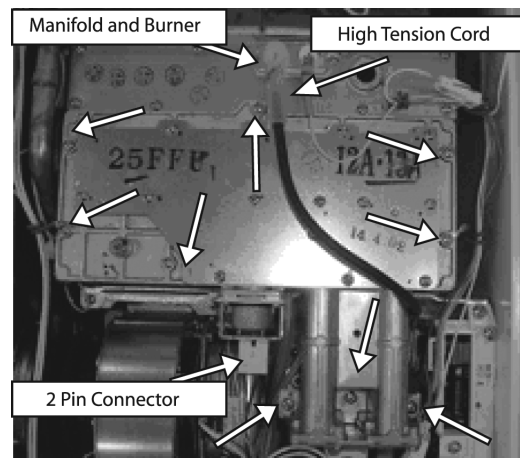

## Manifold Assembly

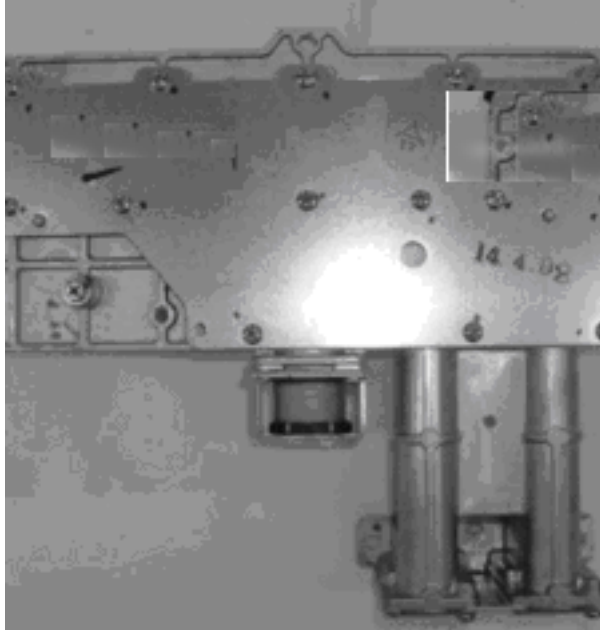

- a. Remove combustion chamber front panel.
- b. Remove burner unit.

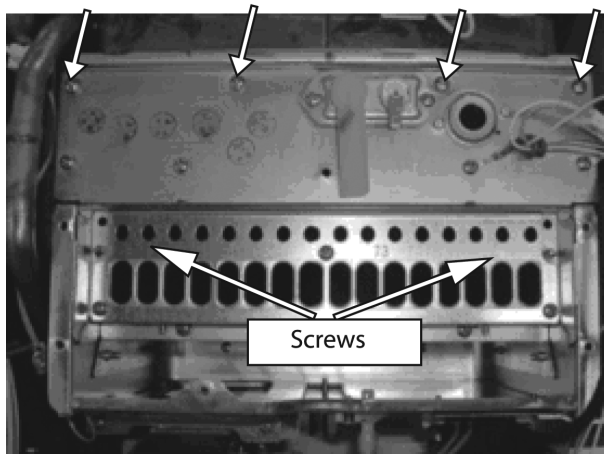

- c. Pull off burner unit

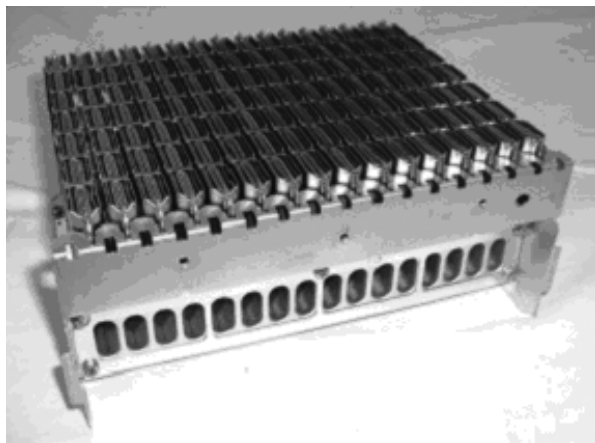

## 8) Removal of the Gas Control

- a. Remove manifold (refer to point 7)
- b. Remove back tube
- c. Remove gas connection.

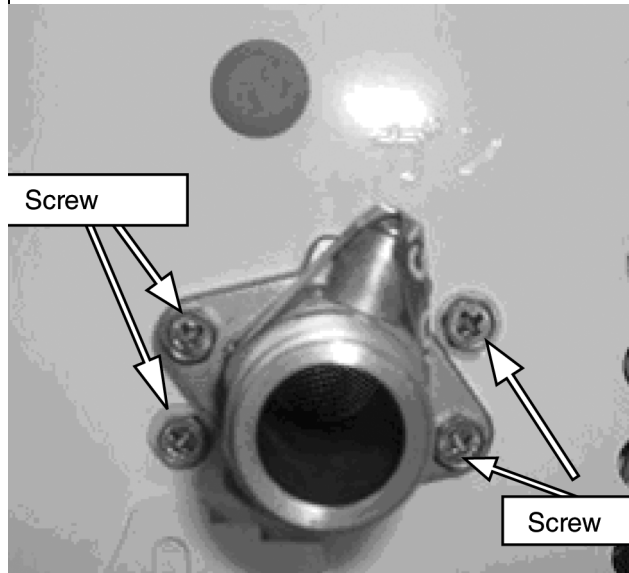

- a. Pull off connectors for gas control modulation valve and solenoid valve.

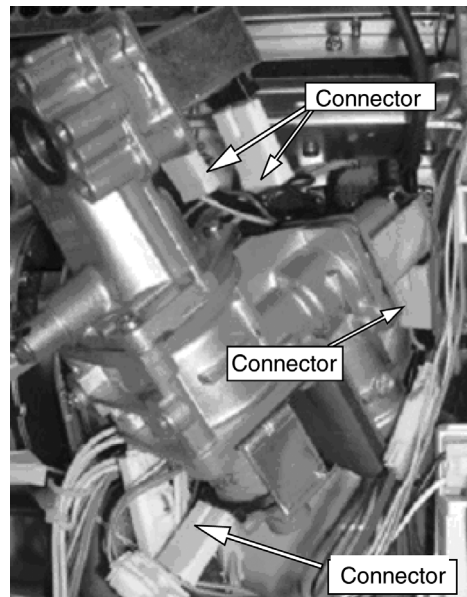

## Gas Control

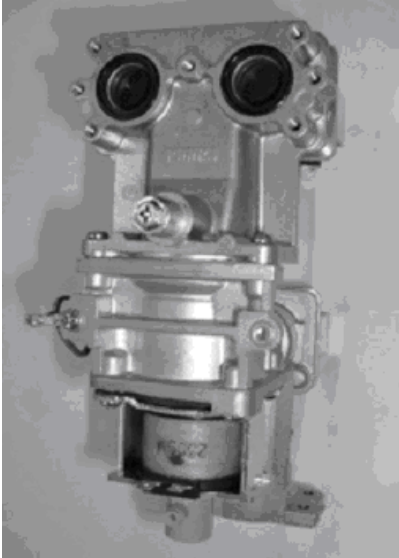

### 9) Removal of Flame rod and spark plug

- Remove flame rod terminal and tighten sparkler lead.
- Remove flame rod and spark plug.

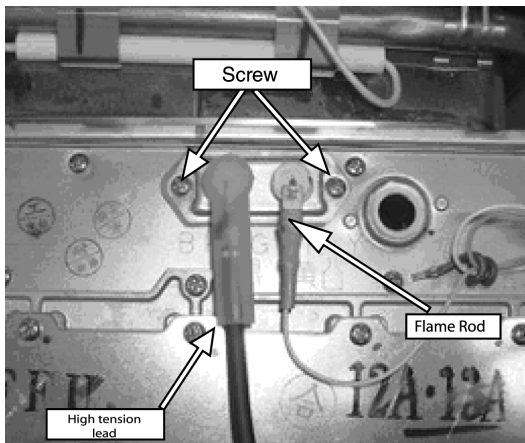

- Remove of High Tension lead

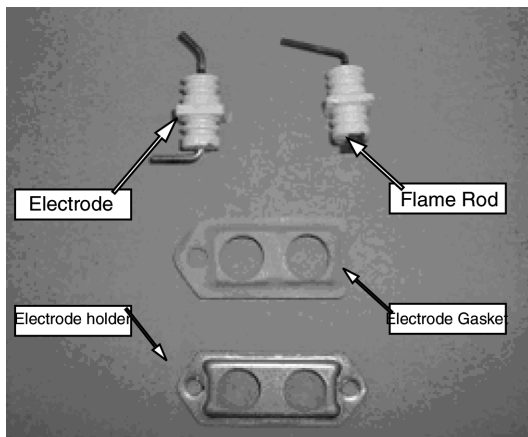

### 10) Removal of Outgoing Water Thermistor

- Remove thermistor fixing screw.
- Remove 2 pin connection outgoing water thermistor

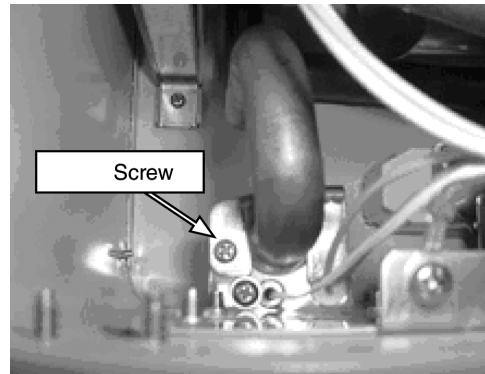

### Heat Exchanger Thermistor



### 11) Removal of Heat Exchanger Thermistor 2632WC ONLY

- Remove thermistor holder
- Remove 2 pin connector

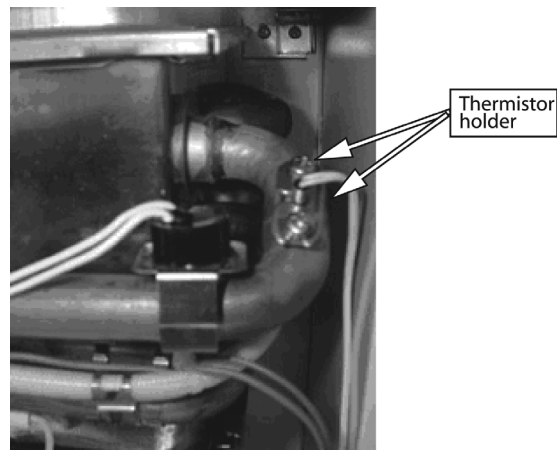

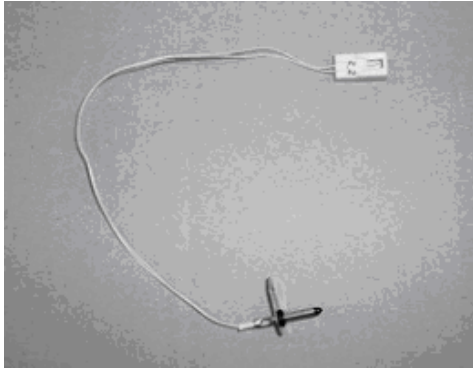

**12) Removal of Bypass Servo  
REU-V2632WC - (HD200E) ONLY**

- a. Remove fan motor (Refer to point 16)
- b. Remove 3 pin connector
- c. Remove 2 pin connector
- d. Remove 6 pin connector and 5 pin connector
- e. Remove bracket for water connection tube.

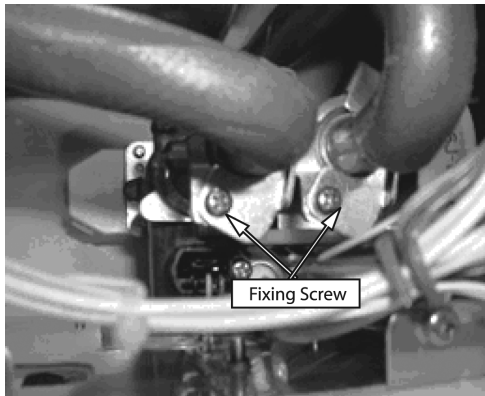

**f. Removal of inlet water connection**

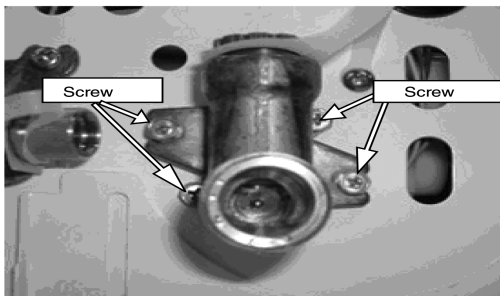

- g. Remove bypass servo and water flow servo
- h. Remove fitting screws of bypass servo

**i. Flow sensor and water flow servo**

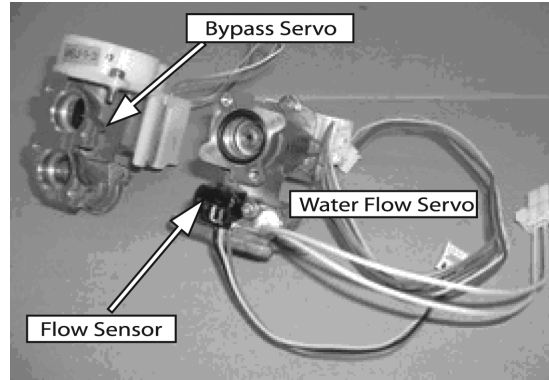

**13) Removal of Anti Frost Switch**

- a. Remove 2 pin connection for anti frost switch
- b. Remove Anti Frost switch

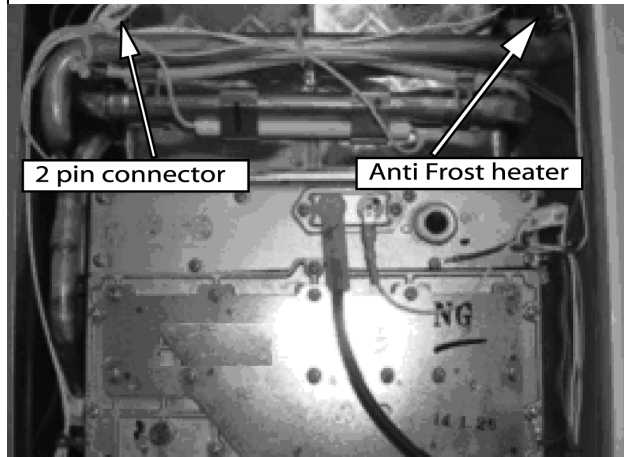

**c. Anti Frost switch**



#### 14) Removal of Anti Frost heater

- a. Remove 2 pin connection of Anti Frost heater
- b. Remove bracket on hot water connection.
- c. Remove Anti Frost heater.

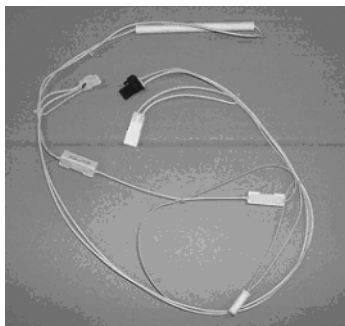
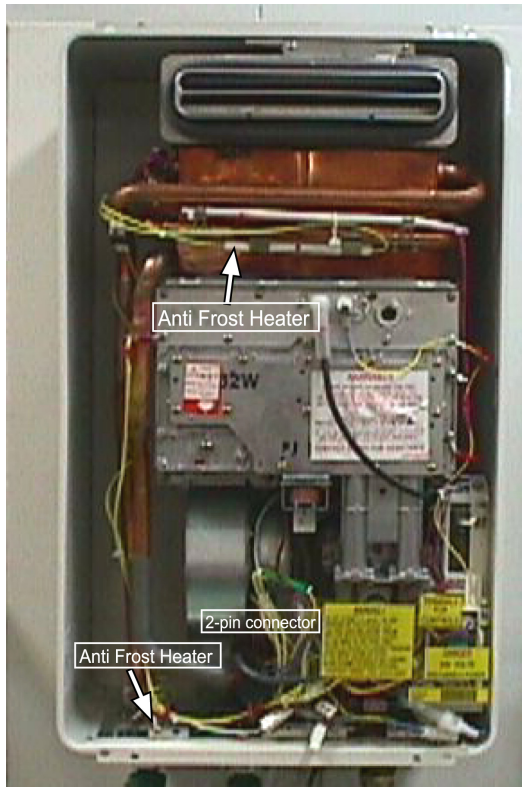

#### 15) Removal of the Fan Motor

- a. Remove 4 pin connector to fan motor.
- b. Remove 2 pin connector of solenoid valve.

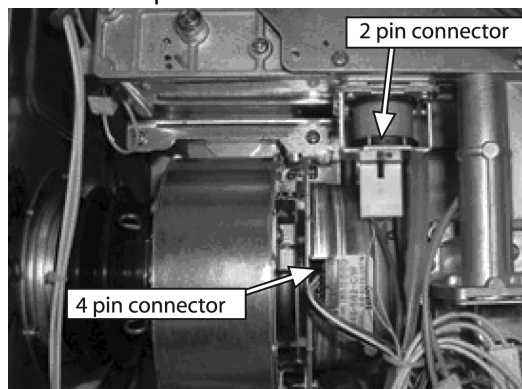

- c. Remove fan motor screws (x 2)

- d. Remove fan motor assembly by sliding forward

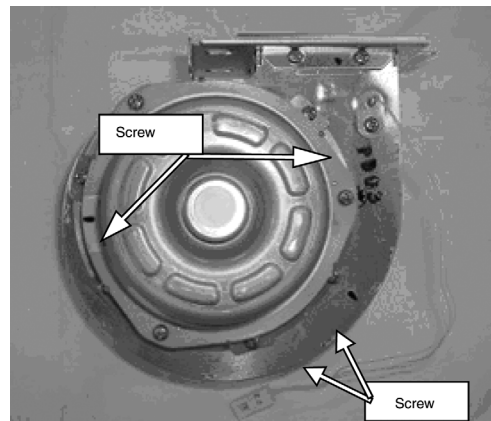

- e. Remove fan motor from housing via 3 screws



## 16) Removal of Heat Exchanger

- a. Remove PCB
- b. Remove fan motor
- c. Remove 2 pin connector of thermal fuse
- d. Remove flame rod terminal of high tension cord
- e. Remove anti frost heater switch
- f. Remove 2 pin connector
- g. Remove 3 pin connector
- h. Remove fixing screws of the heat exchanger unit
- i. Remove heat exchanger screws

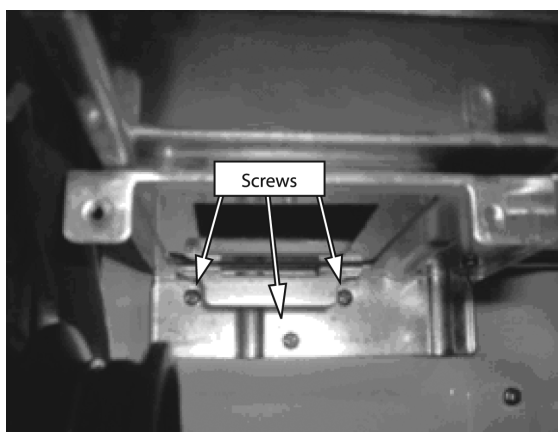
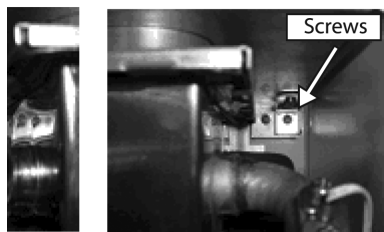
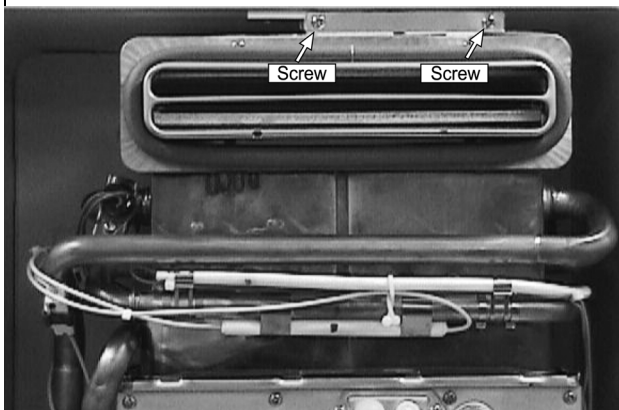

## j. Remove Bypass tube - (REU-V2630 Models ONLY)

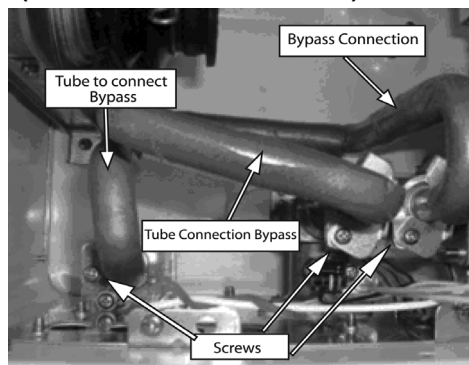

## k. Pull out heat exchanger screws

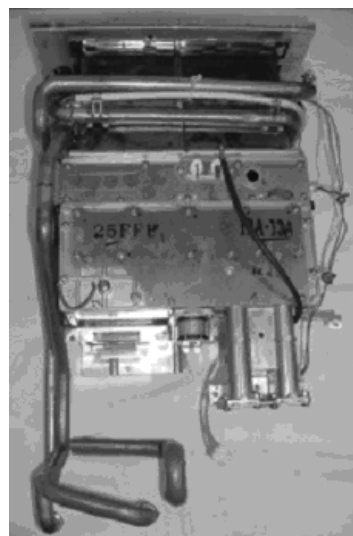

- l. Remove **manifold and burner unit.**
- m. Remove **thermal fuse, over heat switch, sparker, hex thermister and back pressure joint.**

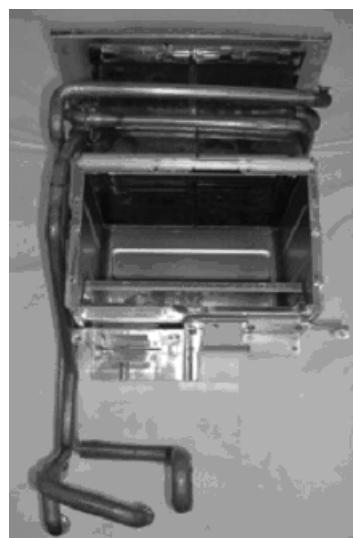

## 17) Removal of Thermal Fuse

- a. Remove heat exchanger.
- b. Remove Thermal Fuse.

After removal of thermal fuse fitting procedure is as follows:

### Heat Exchanger Front

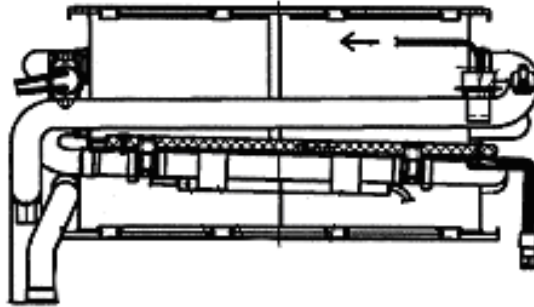

### Heat Exchanger Right

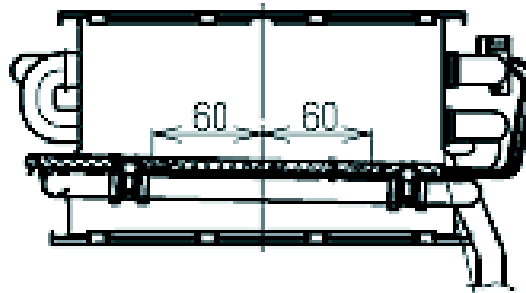

### Heat Exchanger Left

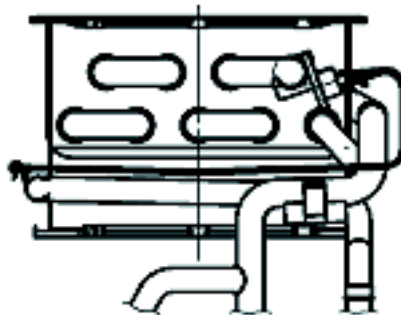

### Heat Exchanger Right

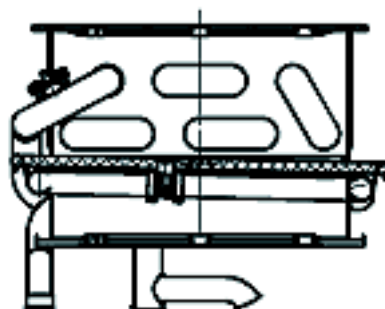



## 19. Parts List

---

**NOTE:**

**Some Part details may have changed since publication of this manual.  
Contact Rinnai to confirm spare parts details before ordering.**

**“REU-V1620WG / REU-V1620WB / REU-V1620WS” on page 37**

**“REU-V2024WG” on page 40**

# REU-V1620WG / REU-V1620WB / REU-V1620WS

Effective: 30/08/2007

E

NO	Part Name	RA Part No.	11 Digit Code	REU-V1620WG	REU-V1620WB	REU-V1620WS(60)
				Quantity		
000	Main Body (Outer Case)	92092049	014-445-000	1		
000	Main Body (Outer Case)	92092050	014-445-000		1	
000	Main Body (Outer Case)	92092050	014-445-000			1
001	Panel Front	92099952	019-3426000	1		
001	Panel Front - Dune	92099953	019-3427000		1	
001	Panel Front - Dune	92099954	019-3435000			1
002	Panel Front Packing		580-0039000	3	3	3
010	Wall Hang Bracket		106-329-000	2	2	2
011	Blind Packing		510-893-000	1	1	1
012	Rubber Bushing C		194-140-000	1	1	1
013	Harness Easy Connect	92099955	106-651-000	1	1	1
014	Cable Seal Packing	92099984	580-0105000	1	1	1
015	Piping Reinforce		044-156-000	1	1	1
100	Inlet (3/4") Gas	92081587	106-290-000	1	1	1
101	Screw Test Point	92099956	501-275-005	2	2	2
102	Gas Control	92095018	120-0015000	1	1	1
103	Manifold LP	92093624	101-592-000	1	1	1
103	Manifold NG	92093632	101-593-000	1	1	1
104	Manifold Packing Upper		580-0106000	1	1	1
105	Manifold Packing Lower		580-0107000	1	1	1
106	Burner Case Front		098-0624000	1	1	1
107	Packing		580-589-000	1	1	1
108	Dumper		140-722-000	1	1	1
109	Lean & Rich Bunsen Burner		157-083-000	14	14	14
	Burner Assembly		157-137-000	1	1	1
110	Burner Case Rear		098-402-000	1	1	1
111	Combustion Chamber Front Panel		019-715-000	1	1	1
112	Combustion Chamber Front Panel Upper		580-591-000	1	1	1
113	Electrode	92086974	202-156-000	1	1	1
114	Electrode FR	92093640	230-057-000	1	1	1
115	Packing Electrode RH	92086990	580-507-000	1	1	1

**REU-V1620WG / REU-V1620WB / REU-V1620WS**

NO	Part Name	RA Part No.	11 Digit Code	REU-V1620WG-AK	REU-V1620WB-AK	REU-V1620WS(60)-AK
117	Sleeve Electrode	92087030	518-035-000	1	1	1
120	Heat Exchanger	92093657	314-538-000	1	1	1
121	Water Connecting Tube Retainer		538-615-000	1	1	1
122	Bracket H/Exchanger Outlet	92099548	537-502-000	1	1	1
130	Exhaust Flue	92098466	055-787-000	1	1	1
131	Exhaust Opening Packing		580-593-000	1	1	1
132	Front Panel Seal Packing		580-594-000	1	1	1
150	Comb Fan Motor	92093665	222-512-000	1	1	1
151	Fan Casing Assembly		035-870-000	1	1	1
	Comb Fan Assy		222-612-000			
400	Inlet (1/2") Water	92097906	333-300-000	1	1	1
401	Plug Band		553-119-000	1	1	1
402	Filter Water O Large	92083773	196-062-000	1	1	1
404	Rectifier		330-107-000	1	1	1
405	Water Flow Servo	92099957	301-152-000	1	1	1
406	Water Flow Servo Cover		098-1445000	1	1	1
408	Connection (1/2") H/W	92098458	333-303-000	1	1	1
409	Hot Water Plug Band		553-043-000	1	1	1
410	Valve Press Relief	92081751	337-048-000	1	1	1
700	PCB Main	92099958	200-0418000	1	1	1
701	EC Cover -2-A		098-1853000	1	1	1
701	EC Cover -2-Z		098-1854000			
702	Electric Control Cover		098-0627000	1	1	1
703	Sparker	92095026	261-157-000	1	1	1
704	Lead HT	92092253	203-828-000	1	1	1
705	Ignitor Bracket		537-0619000	1	1	1
706	Surge Arrestor	92093699	210-605-000	1	1	1
707	Sub Circuit Board Cover		098-1855000	1	1	1
708	Bracket		537-0618000	1	1	1
709	Elec Cord	92089051	206-226-000	1	1	1
710	Harness Fuse	92099959	290-1284000	1	1	1

**REU-V1620WG / REU-V1620WB / REU-V1620WS**

<b>NO</b>	<b>Part Name</b>	<b>RA Part No.</b>	<b>11 Digit Code</b>	<b>REU-V1620WG-AK</b>	<b>REU-V1620WB-AK</b>	<b>REU-V1620WS(60)-AK</b>
712	Switch Thermal	92097187	234-444-000	1	1	1
713	Heater Fixing Plate		537-0440000	4	4	4
715	Harness Power	92095027	290-1285000	1	1	1
716	Harness Magnet	92095028	290-1286000	1	1	1
717	Harness Sensor	92099960	290-1292000	1	1	1
718	Fuse Thermal	92098300	290-0491000	1	1	1
719	Thermal Fuse Fixing Plate		537-505-000	2	2	2
720	Thermal Fuse Fixing Plate		537-0110000	2	2	2
721	Sensor MR	92092288	243-072-000	1	1	1
722	Thermistor	92095030	233-246-000	1	1	1
725	Harness Remote Control	92099961	290-1288000	1	1	1
800	Earth Screw		501-889-000	1	1	1
801	Truss Screw		501-973-010	3	3	3
802	Screw		501-0064000	3	3	3
803	Tapping Screw		501-737-000	1	1	1
804	Thermistor Fixing Screw		501-295-000	1	1	1
820	O-Ring	90195165	520-300-010	2	2	2
821	O-Ring Gas Con	92072859	520-043-010	1	1	1
822	O-Ring Gas Control	92096502	580-180-000	2	2	2
825	O-Ring Thermistor	92062249	520-209-010	1	1	1
826	O-Ring	92062348	520-281-010	1	1	1
827	O-Ring Heat Exchanger	92072800	520-255-010	1	1	1
828	O-Ring Heat Exchanger	92062207	520-193-010	1	1	1
829	O-Ring Heat Exchanger Inlet	92062199	520-048-010	1	1	1
830	O-Ring In/Out Water	92071182	520-049-010	1	1	1
888	Operation Manual		623-344-700	1	1	1
889	Establishment Manual		K23-366-800	1	1	1

# REU-V2024WG

Effective: 30/8/2007

NO	Part Name	RA Part No.	11 Digit Code	REU-V2024WG-AK
000	Main Body (Outer Case)	92092049	014-445-000	1
000	Main Body (Outer Case)	92092050	014-446-000	
000	Main Body (Outer Case)	92092050	014-446-000	
001	Panel Front - Beige	92099963	019-3423000	1
001	Panel Front - Dune	92099964	019-3424000	
001	Panel Front - Dune	92099965	019-3432000	
002	Front Panel Packing		580-0039000	3
010	Wall Hang Bracket		106-329-000	2
011	Blind Packing		510-893-000	1
012	Rubber Bushing C		194-140-000	1
013	Harness Easy Connect	92099955	106-651-000	1
014	Cable Seal Packing	92099984	580-0105000	1
015	Piping Reinforce		044-156-000	1
100	Inlet (3/4") Gas	92081587	106-290-000	1
101	Screw Test Point	92099956	501-275-005	2
102	Gas Control	92095018	120-0015000	1
103	Manifold LP	92093764	101-594-000	1
103	Manifold NG	92093814	101-595-000	1
104	Manifold Packing Upper		580-0108000	1
105	Manifold Packing Lower		580-0109000	1
106	Burner Case Front		098-0625000	1
107	Packing		580-590-000	1
108	Dumper		140-723-000	1
109	Lean and Rich Bunsen Burner		157-083-000	18
	Burner Assembly		157-138-000	1
110	Burner Case Rear		098-403-000	1
111	Combustion Chamber Front Panel		019-1676000	1
112	Combustion Chamber Front Panel Upper		580-596-000	1
113	Electrode	92086974	202-156-000	1

**REU-V2024WG**

NO	Part Name	RA Part No.	11 Digit Code	REU-V2024WG-AK
114	Electrode FR	92093640	230-057-000	1
115	Packing Electrode RH	92086990	580-507-000	1
116	Electrode Holder RH	92087006	580-505-000	1
117	Sleeve Electrode	92087030	518-035-000	1
120	Heat Exchanger	92093822	314-539-000	1
120	Heat Exchanger	92099966	314-522-000	
121	Water Connecting Tube Retainer		538-615-000	1
122	Bracket H/Exchanger Outlet	92099548	537-502-000	1
130	Exhaust Flue	92099967	055-788-000	1
131	Exhaust Opening Packing		580-592-000	1
132	Front Panel Seal Packing		580-600-000	1
150	Fan Comb	92093665	222-512-000	1
151	Fan Casing		035-870-000	1
	Fan Comb Assembly		222-612-000	1
400	Inlet (1/2") Water	92097906	333-300-000	
400	Inlet (3/4") Water	92099968	333-301-NPB	1
401	Plug Band		553-119-000	1
402	Filter Water O Large	92083773	196-062-000	1
404	Rectifier		330-107-000	1
405	Water Flow Servo & Sensor Assy	92099957	301-152-000	1
406	Water Flow Servo Cover		098-1445000	1
407	Water Flow Sensor	92099969	301-154-000	
408	Conn (1/2") HW	92098458	333-303-000	
408	Water Outlet (3/4")	92099970	333-304-000	1
409	Hot Water Plug Band		553-043-000	1
410	Valve Press Relief	92081751	337-048-000	1
700	PCB Main	92099958	200-0418000	1

**REU-V2024WG**

NO	Part Name	RA Part No.	11 Digit Code	REU-V2024WG-AK
700	PCB Main	92099971	200-0419000	
701	EC Cover -2-A		098-1853000	1
701	EC Cover -2-Z		098-1854000	
702	Electric Control Cover		098-0627000	1
703	Sparker	92095026	261-157-000	1
704	Lead HT	92092253	203-828-000	1
705	Ignitor Bracket		537-0619000	1
706	Surge Arrestor	92093699	210-605-000	1
707	Sub Circuit Board Cover		098-1855000	1
708	Bracket		537-0618000	1
709	Elec Cord	92089051	206-226-000	1
710	Fuse Harness -2	92099959	290-1284000	1
711	Heater Anti Frost	92098318	213-001-000	1
712	Switch Thermal	92097187	234-444-000	1
713	Heater Fixing Plate		537-0440000	4
715	Harness Electric Power	92095027	290-1285000	1
716	Harness Magnet Valve	92095028	290-1286000	1
717	Sensor Harness	92099960	290-1292000	1
717	Sensor Harness	92099962	290-1295000	
718	Fuse Thermal	92099621	290-0492000	1
719	Thermal Fuse Fixing Plate		537-505-000	2
720	Thermal Fuse Fixing Plate		537-0110000	2
721	Sensor MR	92099988	243-072-000	1
722	Thermistor	92095030	233-246-000	1
725	Remote Control Harness	92099961	290-1288000	1
800	Earth Screw		501-889-000	1
801	Truss Screw		501-973-010	3
802	Screw		501-0064000	3
803	Tapping Screw		501-737-000	1

**REU-V2024WG**

<b>NO</b>	<b>Part Name</b>	<b>RA Part No.</b>	<b>11 Digit Code</b>	<b>REU-V2024WG-AK</b>
804	Thermistor Fixing Screw		501-295-000	1
820	O-Ring (S4)	90195165	520-300-010	2
821	O-Ring Gas Con	92072859	520-043-010	1
822	O-Ring Gas Control	92096502	580-180-000	2
825	O-Ring Thermistor	92062249	520-209-010	1
826	O-Ring	92062348	520-281-010	1
827	O-Ring Heat Exchanger	92072800	520-255-010	1
828	O-Ring Heat Exchanger	92062207	520-193-010	1
829	O-Ring Heat Exchanger Inlet	92062199	520-048-010	1
830	O-Ring In/Out Water	92071182	520-049-010	1
888	Operation Manual		623-344-700	1
888	Operation Manual		623-342-100	
889	Establishment Manual		K23-366-800	1



# 20. Exploded Diagram

REU-V1620WG/REU-V1620WB/REU-V1620WS

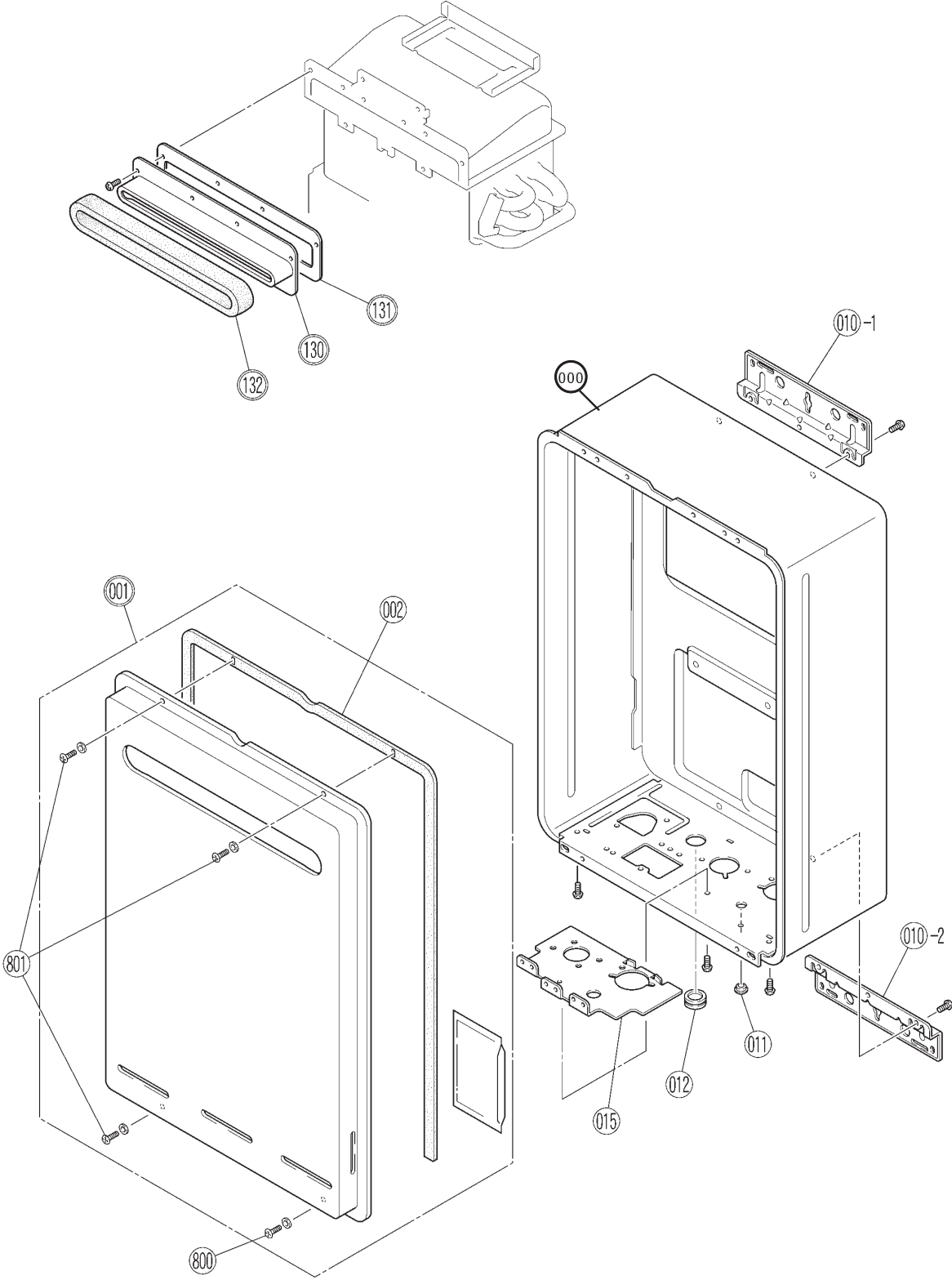

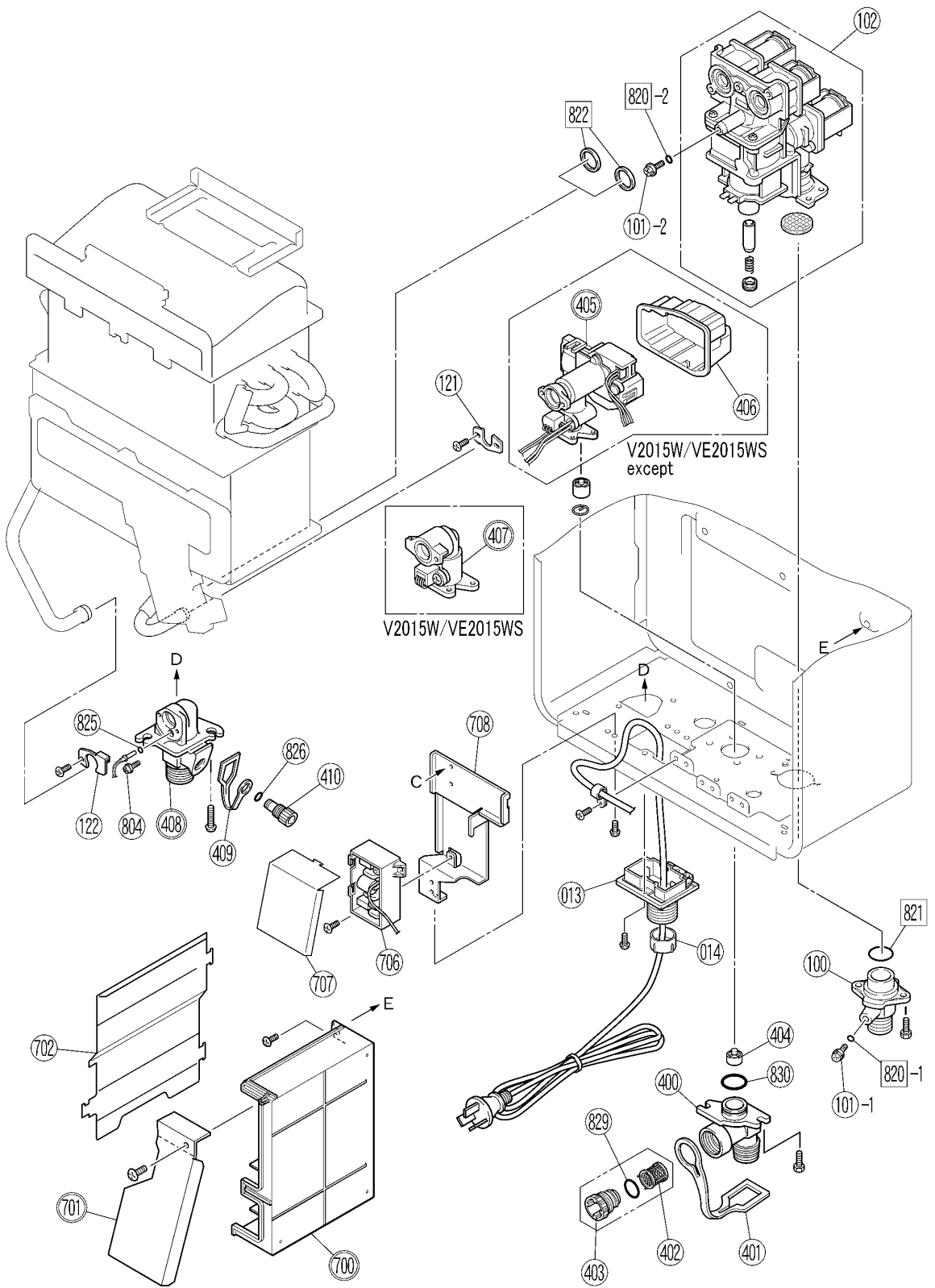

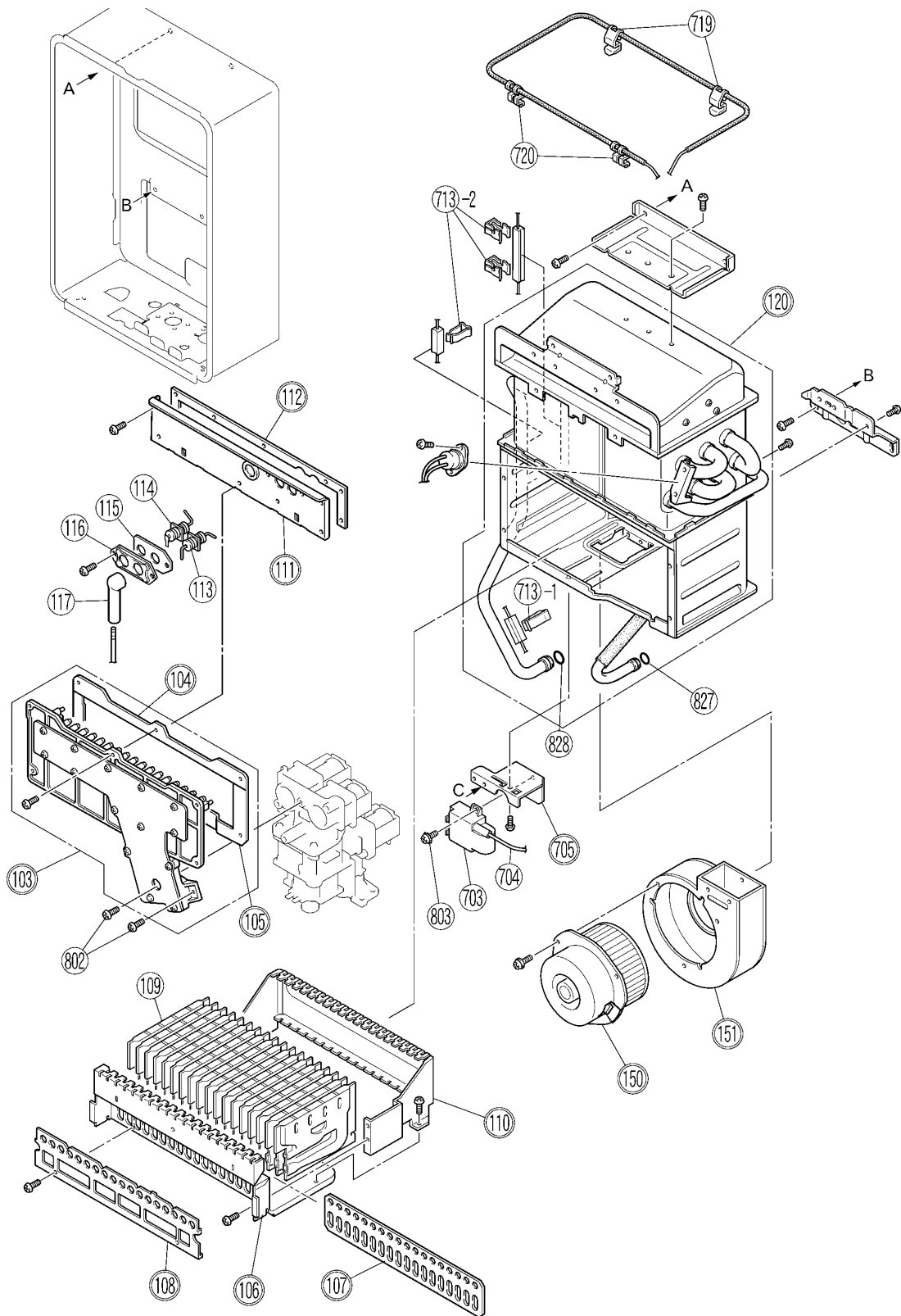

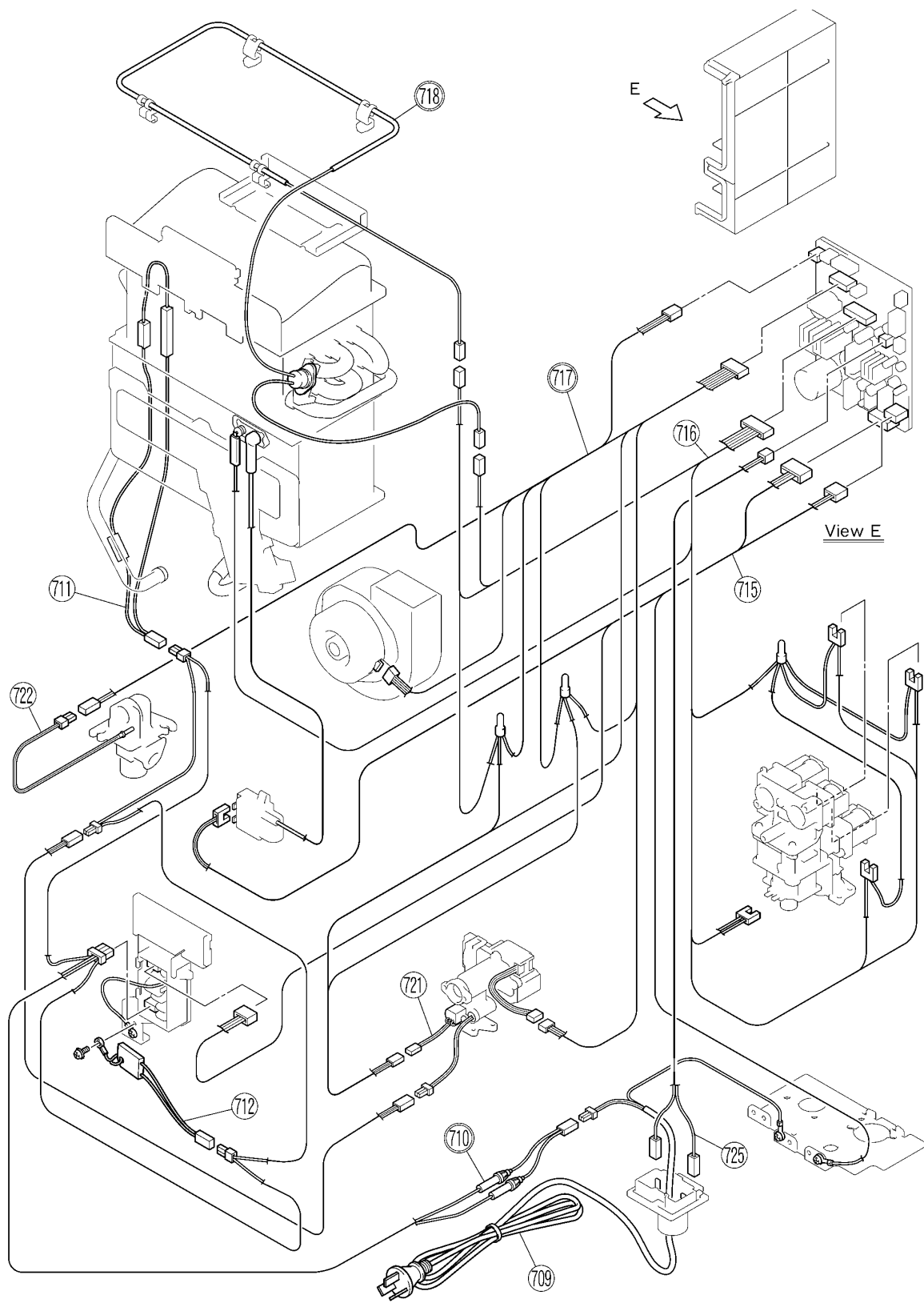

# REU-V2024WG

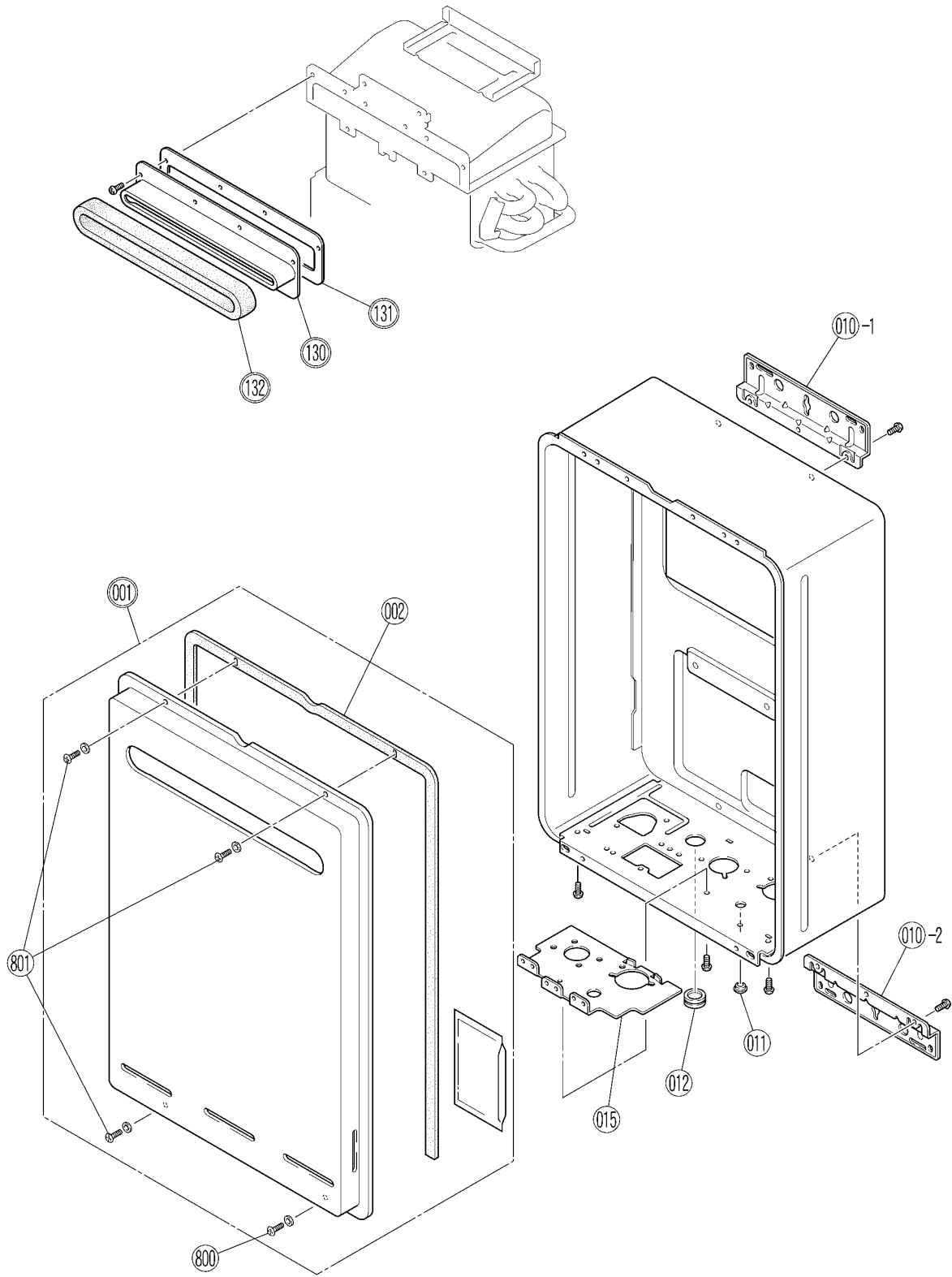

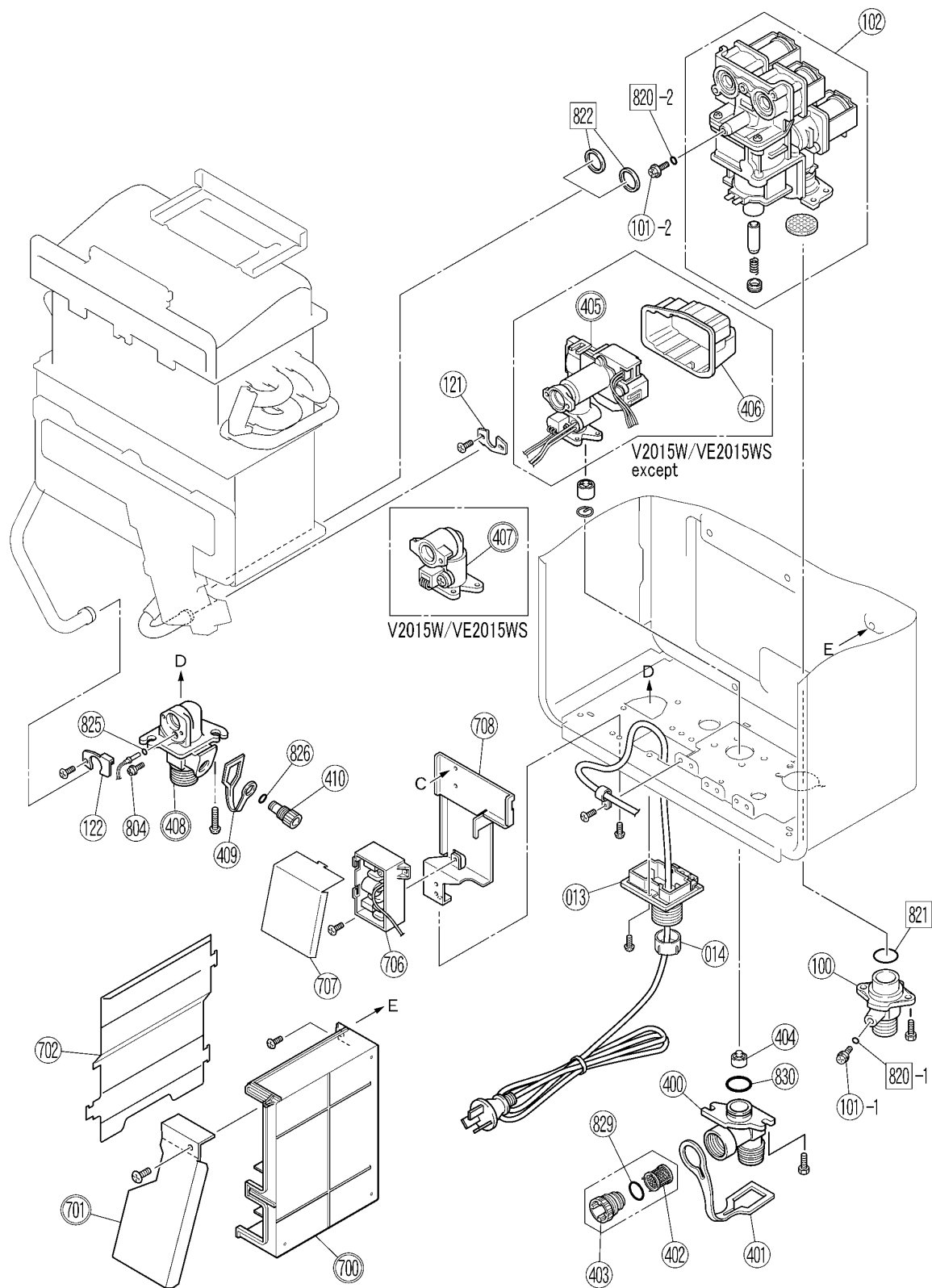

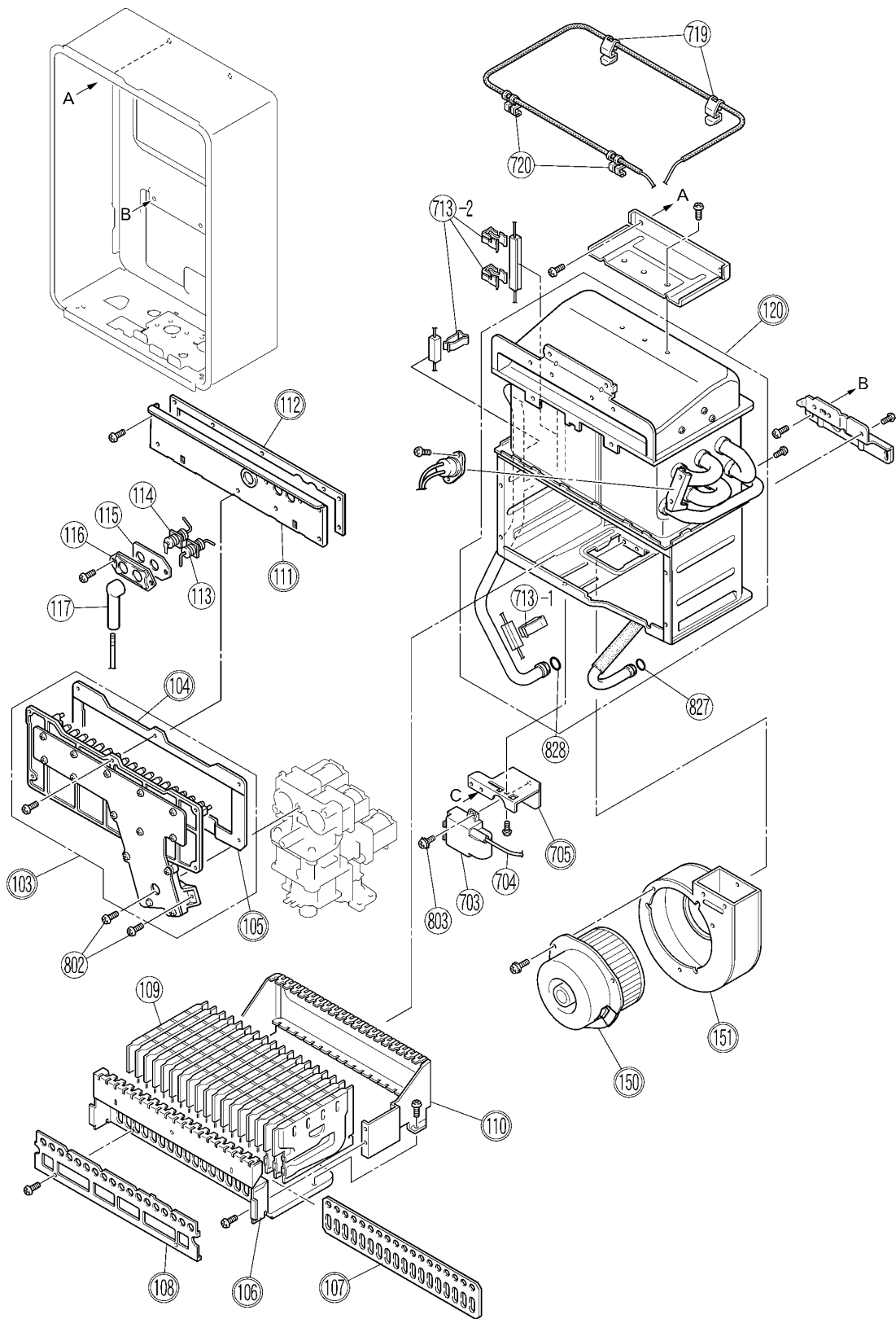

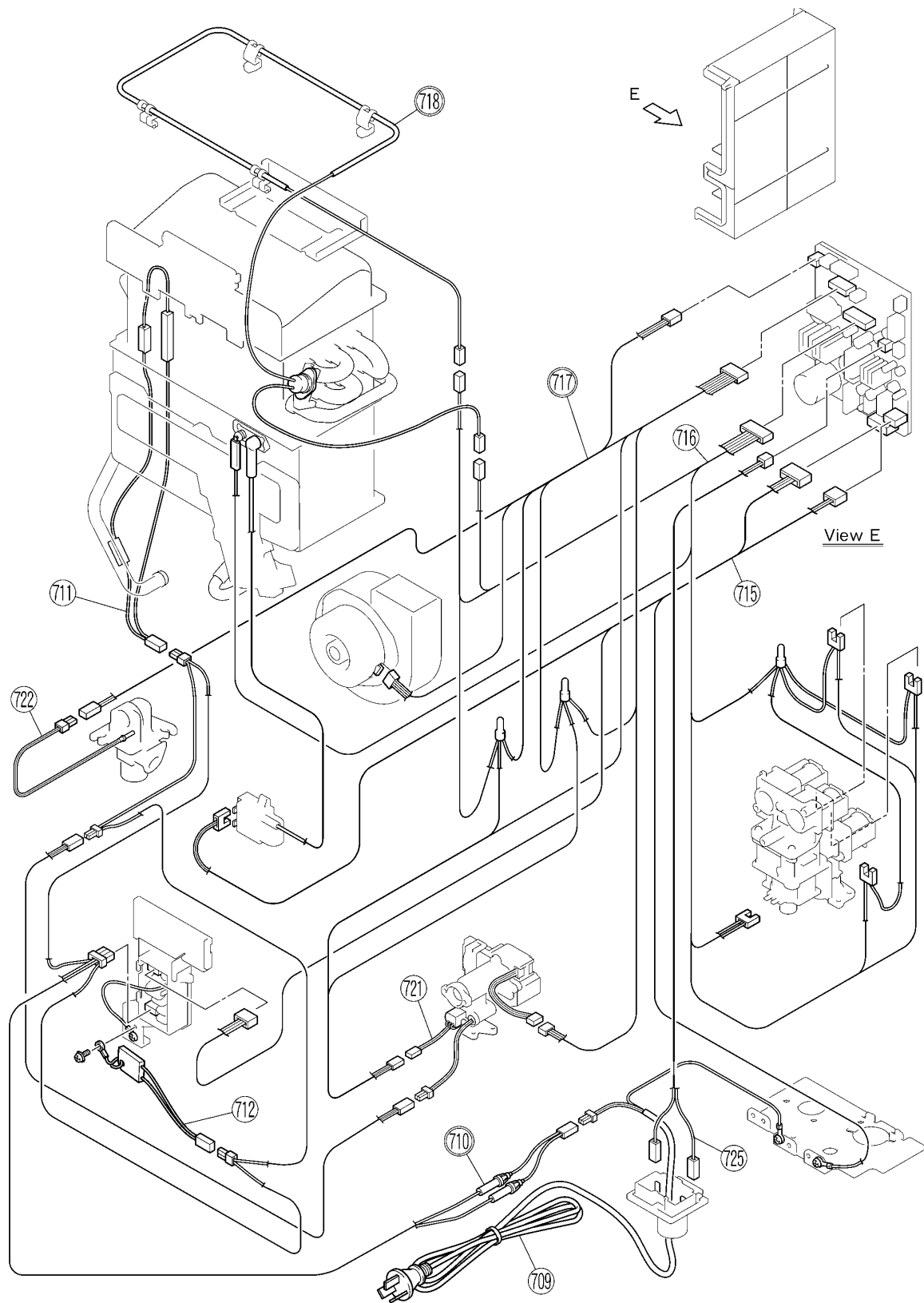



# Rinnai

**Rinnai Australia Pty. Ltd.** ABN 74 005 138 769

## Head Office

10-11 Walker Street,  
Braeside, Victoria 3195  
P.O. Box 460  
Tel: (03) 9271 6625  
Fax: (03) 9271 6622

Rinnai has a Service and Spare Parts network with personnel who are fully trained and equipped to give the best service on your Rinnai appliance. If your appliance requires service, please call our Hot Water Service Line. Rinnai recommends that this appliance be serviced every 3 years.

Internet: [www.rinnai.com.au](http://www.rinnai.com.au) E-mail: [enquiry@rinnai.com.au](mailto:enquiry@rinnai.com.au)

## National Help Lines

### Spare Parts & Technical Info

Tel: 1300 555 545\*

Fax: 1300 300 141\*

*\*Cost of a local call Higher from mobile or public phones.*

### Hot Water Service Line

Tel: 1800 000 340