

Rinnai

INFINITY REU-V2626W
HD200E REU-V2632WC

SERVICE MANUAL

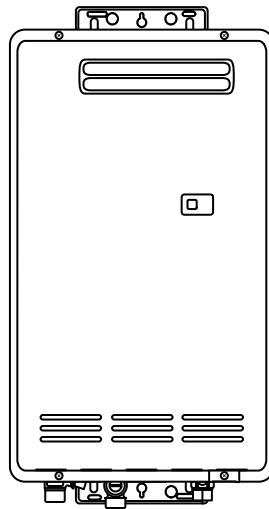

Rinnai High Capacity Continuous Flow Gas Hot Water System

NOTE: This manual does not apply to models: REU-V1620WG, REU-V1620WB, REU-V2024WG, REU-V2024WE, REU-V2426WB, REU-V2626WG, REU-VM2630WD, REU-VM2630WC, REU-V2632FFUG, REU-VM2632FFUC



The Australian
Gas Association

All Rinnai products are certified by the Australian Gas Association as compliant to relevant Australian Standards.



ISO 9001 Lic 4983
SAI Global

Head Office Certified

Distributed and serviced in Australia under a Quality System certified as complying with ISO 9001 by SAI Global

Rinnai Australia Head Office is certified as complying with ISO 9001 by SAI Global.



Quality
Endorsed
Company

ISO 9001 Reg 415

Rinnai New Zealand has been certified to ISO 9001 Quality Assurance by Telarc.

Certified
Product



WaterMark

AS3498 Lic W208
SAI Global

All Rinnai products are Certified to WaterMark by SAI Global. WaterMark certification is awarded to products and fittings complying with safety and water contamination standards.

Copyright© Rinnai Australia Pty Ltd ABN 74 005 138 769 ACN 005 138 769

All rights reserved

Produced by Customer Technical Services

October 2005 - Issue 2.

No portion or part of this manual may be copied without prior permission from Rinnai Australia.

Rinnai Australia takes no responsibility for the accuracy or otherwise of information contained in this manual, and reserves the right to make modifications and change specifications without notice.

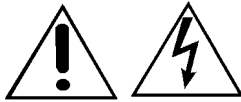

WARNING

Failure to comply with these instructions may result in serious personal injury or damage to the appliance.

ALL WIRING INSIDE THIS APPLIANCE MAY BE AT 240 VOLTS POTENTIAL

ALL SERVICE WORK MUST BE CARRIED OUT BY AN AUTHORISED PERSON.

DO NOT TEST FOR GAS ESCAPES WITH AN OPEN FLAME

This manual has been published by Rinnai Australia Technical Services. While many individuals have contributed to this publication, it will be successful only if you - the reader and customer - find it useful. We would like to extend an invitation to users of this manual to make contact with us, as your feedback and suggestions are valuable resources for us to include as improvements.

Rinnai are constantly working toward supply improved appliances as well as information, and specifications may be subject to alteration at any time.

SM REU-V2626W/REU-V2632WC

Issue N^o2

Table of Contents

Glossary of Terms and Symbols	v
1. Introduction	1
2. Specifications	2
3. Water Flow Rates and Pressures	4
4. Dimensions	8
5. Remote Controls	9
6. Cutaway Diagram	13
7. Operational Flow Chart	14
8. Operation Principles	15
9. Main Components	17
10. Time Charts	18
11. Wiring Diagram	20
12. Dip Switch Settings	22
13. Fault Finding	24
14. Component Circuit Value Table	26
15. Component and Circuit Checks	27
16. Maintenance Monitor / Error History	34
17. Gas Pressure Setting Procedure	36
18. Gas Conversion Procedure	38
19. Dismantling for Service	42
20. Exploded Diagram	51
21. Parts List	56
REU-V2626W	57
REU-V2632WC.....	60
SERVICE CONTACT POINTS	63

Glossary of Terms and Symbols

dB(A)	-	sound pressure level in decibels, “A” range
DC	-	direct current
AC	-	alternating current
WFCD	-	water flow control device
FB	-	feedback information
FF	-	feedforward information
Hz	-	Hertz
IC	-	integrated circuit
kcal/h	-	kilocalorie per hour
kPa	-	kilopascals
LED	-	light emitting diode
L/min	-	Litres per minute
mA	-	milliamps
MJ/h	-	megajoule per hour
mm	-	millimetres
mmH ₂ O	-	millimetres of water (gauge pressure)
OHS	-	overheat switch
PCB	-	printed circuit board
CPU	-	central processing unit
POT	-	potentiometer
rpm	-	revolutions per minute
SV	-	solenoid valve
∅	-	diameter
Δ °C	-	temperature rise above ambient
POV	-	modulating valve
TE	-	thermal efficiency
TH	-	thermistor
T _{IN}	-	temperature of incoming water
T _{OUT}	-	temperature of outgoing water

1. Introduction

The Rinnai V-Series hot water units represents the latest technology in continuous flow, temperature controlled hot water.

Features

- The Infinity 26 and the HD200E NEVER RUN OUT of hot water. Whilst electricity, water and gas supplies are connected, hot water is available whenever hot water taps are open.
- Built into the main micro-processor is the facility to LIMIT THE MAXIMUM TEMPERATURE of the hot water supplied. The water temperature may be limited to various maximum temperatures. This is particularly useful when the hot water unit is installed where young children or the infirm may be using the hot water. The Infinity is delivered with a maximum preset temperature of 55°C and the HD200E at 65°C. If required, the temperature limits can be changed by a service technician. For further information, please contact Rinnai.
- The Infinity is a power flued appliance. It is COMPACT, saving both floor and wall space.
- The temperature of outgoing hot water is CONSTANTLY MONITORED by a BUILT-IN SENSOR. If the temperature of the outgoing hot water rises to more than 3°C above the selected temperature shown on the Digital Monitor (or the pre-set limit when Remote Controls are not fitted), the burner will automatically go out. The burner will ignite again once the outgoing hot water temperature falls below the temperature shown on the Digital Monitor (or the pre-set limit).
- The burner lights automatically when the hot water tap is opened, and goes out when the tap is closed. IGNITION IS ELECTRONIC, therefore there is not pilot light. When the hot water tap is off, no gas is used.
- ‘Deluxe’ or ‘Standard’ Remote Controllers are available as an optional extra. Depending on the models chosen, these offer the following additional features :
 - Bath fill function
 - Voice Prompting
 - Localised Temperature Control for up to one kitchen and two bathroom controllers
 - Clock
- Temperatures selected at the controllers are retained in the SYSTEM MEMORY.
- Operating NOISE LEVEL IS VERY LOW.
- ERROR MESSAGES ARE DISPLAYED on the Remote Controllers, assisting with service.

2. Specifications

Model No.	Infinity REU-V2626W / HD200E REU-V2632WC		
Type of Appliance	Temp.controlled continuous Flow Gas Hot Water Unit		
Operation	With/without remote controls, mounted in kitchen, bathroom, etc.		
Exhaust System	Forced Flue		
Installation	Externally mounted		
Available Default Temperatures (<i>Note 1</i>): (without Remote Controllers)	40° C, 43° C, 50° C, 55° C , 60° C, 65° C, 75° C, (*85° C) (Set by combination of Dip switches on PCB).		
Temperature Range (with Remote Controllers)	Kitchen controller	: 37 ~ 55° C	
	Bathroom controller	: 37 ~ 50° C	
Dimensions (mm)	Width: 350	Height: 600	Depth: 224
Electrical Consumption	Normal	65 W	
	Standby	6 W (with 1 Remote Control)	
	Anti-frost	100 W	
Noise Level	49 dB(A)		
Weight	(Kg)	21	
Connections	Gas	20A (R3/4)	
	Cold Water Supply	20A (R3/4)	
	Hot Water Supply	20A (R3/4)	
Ignition system	Direct Electronic Ignition		
Gas Consumption (Max / Min).	Natural Gas	199 ~ 16 MJ/h	
	Propane Gas	199 ~ 16 MJ/h	
Output (Max/Min) (kW)	(kW)	REU-V2626W: 45.3 / 3.6	REU-V2632WC: 45.2 / 3.7
Hot Water Capacity	2.4 to 26 L/min.		
Thermal efficiency	83%		
NOXaf	46 ppm		
Minimum Operating Water Flow (<i>Note 2</i> : - V2632WC):	2.4 L/min.		
Minimum Operating Pressure (<i>Note 2</i> : - V2632WC):	REU-V2626W - 200 kPa	REU-V2632WC - 140 kPa	
Maximum Operating Water Flow	REU-V2626W - 26 L/min.	REU-V2632WC - 32 L/min.	
Nominal Operating Pressure	Less than 60°C	REU-V2626W - 200 kPa	REU-V2632WC - 140 kPa
	Greater than or equal to 60°C	200 ~ 1000 kPa	
Water Flow Control - V2626W	Water flow sensor, Electronic water flow control		
Water Flow Control - V2632WC	Electronic Water flow sensor flow control & heat exchanger By-pass flow		
Power Supply	Infinity Unit	AC 240 Volts (50 Hz)	
	Remote Control (optional)	DC 12 Volts (Digital)	
Safety Device	Flame Failure	Flame rod	
	Boil dry	Water flow sensor	
	Remaining Flame (OHS)	97° C bi-metal switch	
	Over temperature	95° C lockout thermistor	
	Fusible link	129° C Thermal Fuse	
	Pressure relief valve	Opens 2060 kPa, Closes 1470 kPa	
	Combustion fan rpm check	Integrated circuit system	
	Over current	Glass fuse (3 Amp).	
Remote Control (Optional)	Kitchen control	MC-91-1A or MC-70-2A	
	Bathroom control	MC-91-1A or BC-70-2A	
	Second Bathroom control	MC-91-1A or BC-70-2A	
	Third Bathroom control	MC-91-1A	
Remote Controller Cable (Optional)	Two core sheathed (double insulated) flex with min.cross-sectional		
Manifold Electronic Control System (optional)	MSA-2M, MSA-2S		

Note 1: The default factory setting is 55°C for REU-V2626W. 65°C for REU-V2632WC. The unit can be ordered from Rinnai to be pre-set to any of the other temperatures listed. The unit can be pre-set to any of the temperatures listed by a suitably qualified person. * **Temperatures set at 85° C for REU-V2632W models only.**

Controllers are available with default temperatures up to 75° C. When fitted with controllers, only temperatures not exceeding the default temperatures can be selected. When fitted without controllers, the unit will deliver water at the default temperature. Controllers are not available with 85° C settings.

Note 2: Unit will operate at lower pressures but the maximum rated flow of 32L/min. will not be achieved (REU-V2632WC).

Sensors and Safety Devices

- Heat Exchanger Thermistor: Measures hot water temperature at heat exchanger outlet. If water temperature reaches a predetermined limit, gas supply is stopped.
- Hot Water Delivery Thermistor: Measures hot water temperature at the outlet valve (i.e. the ‘mixed’ temperature).
- Flame Rod: Monitors combustion characteristics inside the combustion chamber. If the flame fails, gas supply is stopped.
- Overheat Switch: Situated on the heat exchanger, gas supply is stopped when water temperature reaches 97° C for a number of seconds.
- Fusible Link: Situated on the heat exchanger, electrical power supply is stopped if the temperature exceeds 129° C.
- Water Pressure Relief Valve: Safeguards the water circuit against excessive inlet pressure. Opens at 2060 kPa, closes at 1470 kPa.
- Electrical Fuse: (3A glass fuse) prevents against over-current.
Surge Protector: prevents against over-current.
- Boil Dry Prevention: If water flow sensor detects no flow, gas supply is stopped.
- Combustion Fan Speed Sensor: In case of combustion fan defect (no rotation of fan) gas supply is stopped.
- Temperature Cutout: If the delivered hot water temperature rises above the required delivery temperature for a number of seconds, the gas supply is stopped.

Combustion Specifications

Gas Type	Injector Size (mm)	Nominal TPP (kPa) * *		Gas Input (MJ/hr)	
		Low	High	Low	High
Natural	1.15	0.140	.79	16	199
	1.80				
Propane (NZ LPG)	0.75	0.219	1.15	16	199
	1.15				

* * The TPP is measured with the cover off the appliance at the regulator test point with supply pressures of 1.13 kPa (NG) and 2.75 kPa (Propane).

3. Water Flow Rates and Pressures

Water Flows

Table 1 shows unmixed and mixed water flow rates and approximate gas consumptions for various temperature rises. The unmixed flow rates are the flow rates available at the given temperature rise directly at the outlet of the water heater. The mixed water flow rates are available at the given temperature rise by mixing hot water from the outlet of the water heater with cold water from the mains supply.

Water Flows can also be calculated by the following formula :

Q = Heat energy available in kW = 46kW for the REU-V2626W and REU-V2632WC

C = Specific heat of water = 4.2KJ/Kg °C. C does not change for the purpose of this calculation.

Δ T = Temperature rise required (°C)

Example:

What is the flow rate available with an incoming water temperature of 10° C and a required temperature of 20° C?

$$\Delta T = 20 - 10 = 10^{\circ} C$$

$$Q = 46$$

$$C = 4.2$$

$M = 60 \times (46 / (4.2 \times 10)) = 66$ l/min. Since 66 is greater than 26 this flow rate is mixed. This result corresponds with the value in Table 1.

Approx. Water Flows & Gas Usage - REU-V2626W / REU-V2632WC All Preset Temp & Less than 60°C.

Models (All Pre-set Temperatures)	Temp Rise (°C)						5						10						15						20					
	Approx. Min / Max Gas Input (MJ/hour)	L/sec	L/min	L/hr	Min Water Pressure (kPa)	Approx. Gas Cons. (MJ/h)	L/sec	L/min	L/hr	Min Water Pressure (kPa)	Approx. Gas Cons. (MJ/h)	L/sec	L/min	L/hr	Min Water Pressure (kPa)	Approx. Gas Cons. (MJ/h)	L/sec	L/min	L/hr	Min Water Pressure (kPa)	Approx. Gas Cons. (MJ/h)	L/sec	L/min	L/hr	Min Water Pressure (kPa)	Approx. Gas Cons. (MJ/h)				
REU-V2626W - Ext.	16-199	0.43	26	1560	200	40	0.43	26	1560	200	80	0.43	26	1560	200	80	0.43	26	1560	200	120	0.43	26	1560	200	160				
Models (All Pre-set Temperatures)	Temp Rise (°C)						25						30						35						40					
REU-V2626W	16-199	0.43	26	1560	200	199	0.36	21.6	1296	100	199	0.31	18.6	1116	70	199	0.27	16.2	972	50	199	0.27	16.2	972	50	199				
Models (All Pre-set Temperatures)	Temp Rise (°C)						45						50						55						60					
REU-V2626W	16-199	0.24	14.4	864	44	199	0.22	13.2	792	32	199	0.2	12	720	25	199	0.18	10.8	648	20	199	0.18	10.8	648	20	199				
Models (Preset temperatures less than 60°C)	Temp Rise (°C)						5						10						15						20					
Rinnai HD200E (REU-V2632WC)	16-199	0.53	32	1920	140	47	0.53	32	1920	140	94	0.53	32	1920	140	94	0.53	32	1920	140	141	0.53	32	1920	140	188				
Models (Preset temperatures less than 60°C)	Temp Rise (°C)						25						30						35						40					
Rinnai HD200E (REU-V2632WC)	16-199	0.44	26.4	1584	100	195	0.37	22.2	1332	65	199	0.37	22.2	1332	65	199	0.32	19.2	1152	50	199	0.28	16.8	1008	40	199				
Models (Preset temperatures less than 60°C)	Temp Rise (°C)						45						50						55						60					
Rinnai HD200E (REU-V2632WC)	16-199	0.25	15	900	30	199	0.22	13.2	792	25	199	0.22	13.2	792	25	199	0.2	12	720	23	199	0.19	11.4	684	20	199				
Models (Preset temperatures less than 60°C)	Temp Rise (°C)						65						70						75						80					
Rinnai HD200E (REU-V2632WC)	16-199	0.17	10.2	612	19	199	0.16	9.6	576	18	199	0.15	9	540	17	199	0.14	8.4	504	16	199	0.14	8.4	504	16	199				

Approx. Water Flows & Gas Usage- REU-V2626W/REU-V2632WC Preset Temp. **Greater than or equal to 60°C**

Models (Preset temps greater than or equal to 60° C)	Temp Rise (° C) ↑				5				10				15				20				
	Approx. Min / Max Gas Input (MJ/hour)	L/sec	L/min	L/hr	Min Water Pressure (kPa)	Approx Gas Cons. (MJ/h)	L/sec	L/min	L/hr	Min Water Pressure (kPa)	Approx Gas Cons. (MJ/h)	L/sec	L/min	L/hr	Min Water Pressure (kPa)	Approx Gas Cons. (MJ/h)	L/sec	L/min	L/hr	Min Water Pressure (kPa)	Approx Gas Cons. (MJ/h)
Rinnai HD200E (REU-V2632WC)	16-199	0.4	24	1440	200	36	0.4	24	1440	200	72	0.4	24	1440	200	108	0.4	24	1440	200	144
Models (Preset temps greater than or equal to 60° C)																					
Rinnai HD200E (REU-V2632WC)	16-199	0.4	24	1440	200	180	0.37	22.2	1332	112.5	199	0.32	19.2	1152	75	199	0.28	16.8	1008	60	199
Models (Preset temps greater than or equal to 60° C)																					
Rinnai HD200E (REU-V2632WC)	16-199	0.25	15	900	45	199	0.22	13.2	792	40	199	0.2	12	720	36	199	0.19	11.4	684	33	199
Models (Preset temps greater than or equal to 60° C)																					
Rinnai HD200E (REU-V2632WC)	16-199	0.17	10.2	612	31	199	0.16	9.6	576	29	199	0.15	9	540	27	199	0.14	8.4	504	25	199
Models (Preset temps greater than or equal to 60° C)																					
Rinnai HD250E (REU-V2632WC)	21-250	0.16	9.6	576	29	250	0.15	9	540	25	250	0.15	9	540	25	250	0.15	9	540	25	250

Notes:

1. All values shown are approximate.
2. Temperature **Rise** = Pre-set temperature of water heater - Incoming Water Temp.
3. Minimum Water pressures quoted are for flow through the water heater only.

Water Pressure

As seen in the table below a minimum supply pressure of 180 kPa is required to operate at the rated flow of 26 L/min. In an actual installation, pressure losses in the plumbing system also need to be considered.

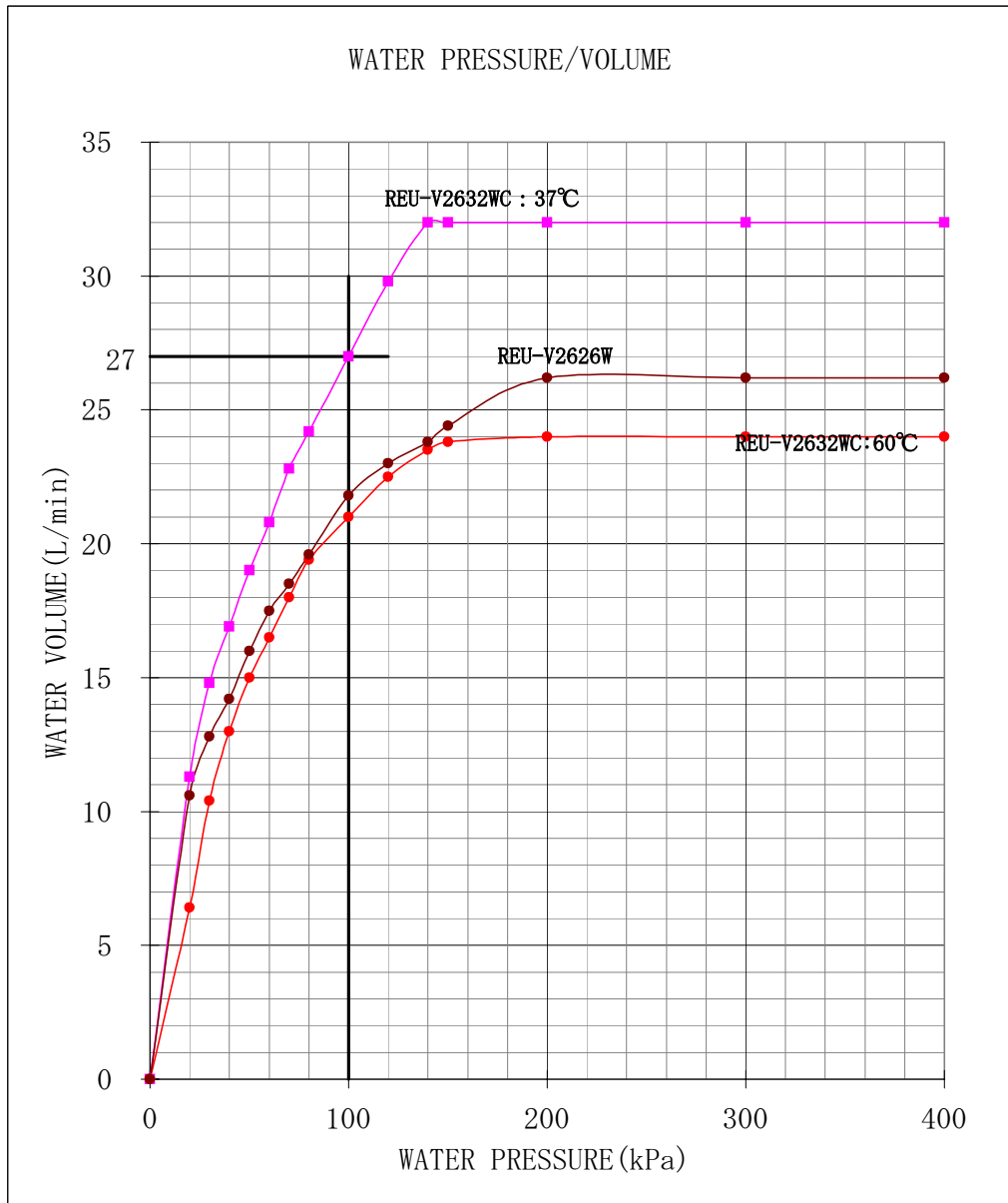

4. Dimensions

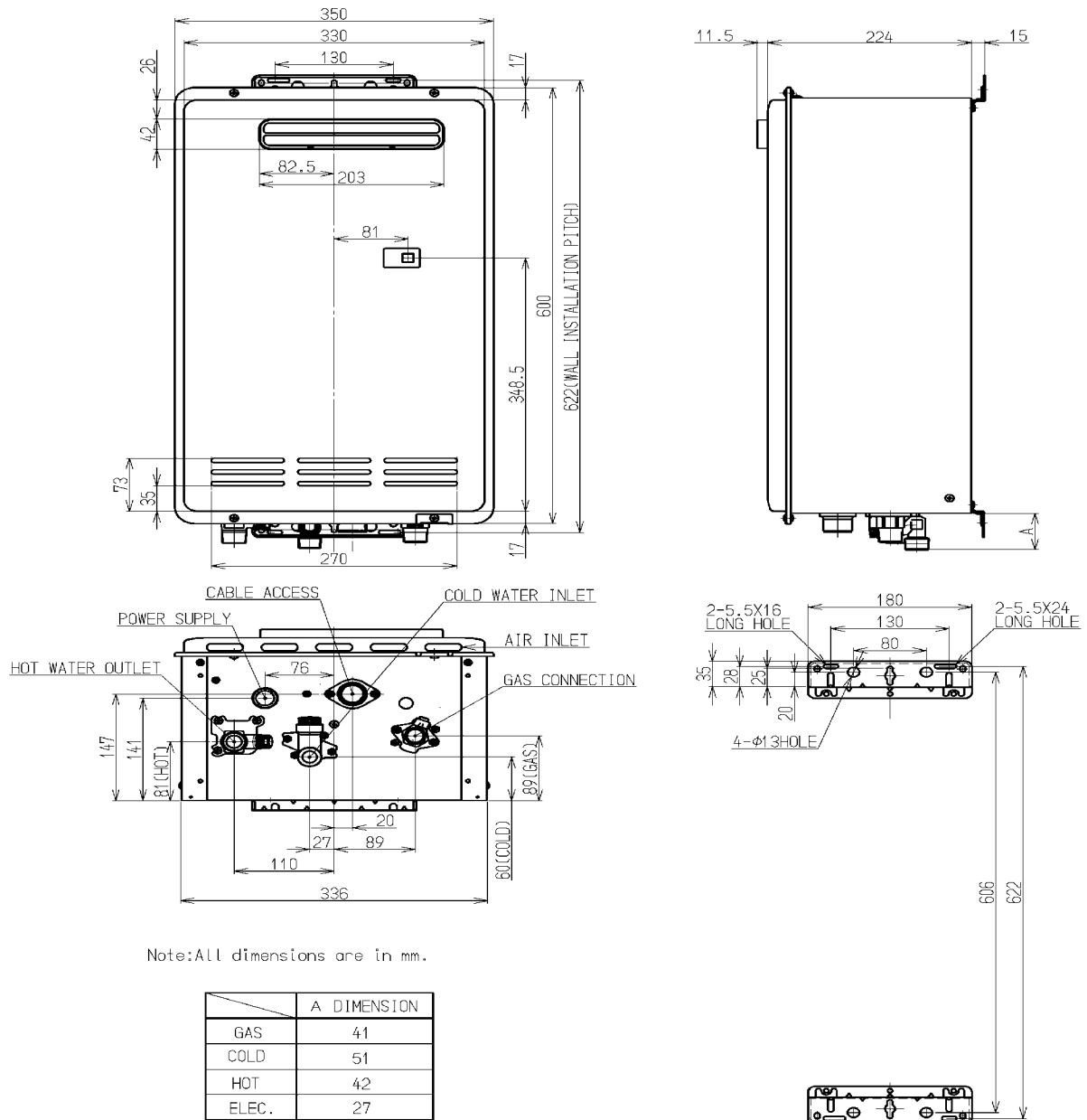

5. Remote Controls

Remote Controls

Remote Controllers are an optional extra. 'Standard' and 'Deluxe' controllers can be fitted.

Standard controllers allow temperature selection only. Deluxe controllers have temperature selection, bath-fill and voice prompting functions. For detailed information regarding controller operation refer to the 'How to use your water heater' booklet supplied with the appliance. Other manufacturers' controllers are NOT compatible with this appliance.

Standard Controller (Model MC-91)

Up to 4 Standard Controllers can be fitted to the appliance. They are normally installed in the areas where the majority of hot water is used, for example, the kitchen, bathroom, ensuite and laundry.

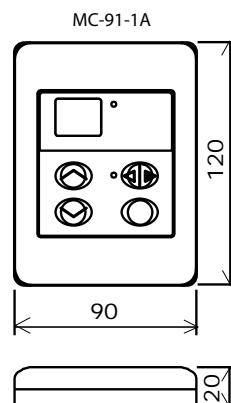

Deluxe Kitchen Remote Control (MC-70)and (BC-70A)

Deluxe controllers have 'Kitchen' (MC-70-2A) and 'Bathroom' (BC-70-2A) versions. 'Kitchen' controls are intended for the Kitchen or other convenient area where the majority of hot water is used. Bathroom Controllers are intended to be fitted in the bathroom or ensuite and allow the user to have a bath filled to the required level and temperature automatically.

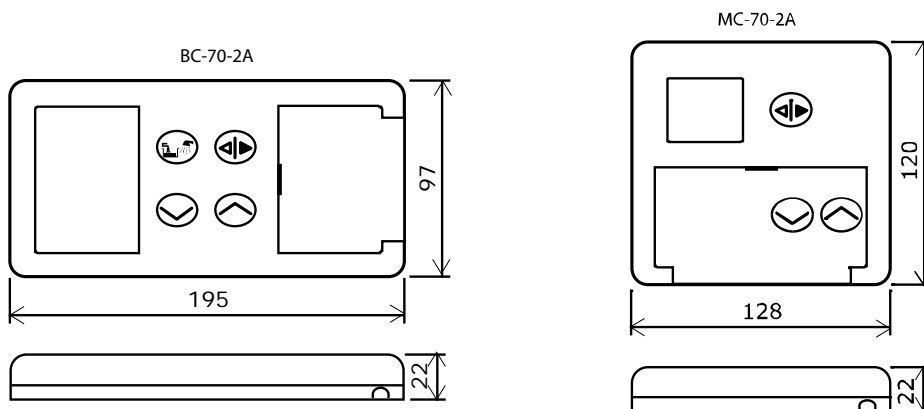

Up to three 'Deluxe' Controllers can be connected		
Kitchen	Bathroom	Ensuite
MC70-2A		
MC70-2A		
MC70-2A	BC70-2A	
MC70-2A	BC70-2A	BC70-2A

If a fourth Controller is required a Standard Controller can be included			
Kitchen	Bathroom	Ensuite	Laundry
MC70-2A			
MC70-2A			
MC70-2A	BC70-2A		
MC70-2A	BC70-2A	BC70-2A	MC91-1A

Positioning of Controllers

Controllers must be installed in shaded and clean locations. They should be fitted out of reach of children (suggested height from floor at least 1500mm). Controllers are water resistant, however, durability is improved when positioned outside the shower recess or at least 400mm above the highest part of a sink, basin or bath.

DO NOT INSTALL THE CONTROLLERS

- NEAR A HEAT SOURCE, SUCH AS A COOK TOP, STOVE OR OVEN. HEAT, STEAM, SMOKE AND HOT OIL MAY CAUSE DAMAGE
- IN DIRECT SUNLIGHT
- OUTDOORS UNLESS AN ENCLOSURE IS PROVIDED WHICH PROTECTS THE CONTROLLER AGAINST SUNLIGHT AND DUST INGRESS.
- AGAINST A METAL WALL UNLESS THE WALL IS EARTHED IN ACCORDANCE WITH AS/NZ3000.

Remote Controller Connection

Remote controls operate at extra low voltage (12 Volts DC) which is supplied from the appliance. Controllers are supplied with 15 m of electrical cable. The cable wires for connection to the appliance are fitted with spade terminals.

Extension cables are available from Rinnai. Alternatively, a two core sheathed (double insulated) flex with minimum cross-sectional area of 0.5 mm² can be used. Maximum cable length is 50 m.

For connection refer to the “CONNECTING REMOTE CONTROL CABLES” section.

If the front cover of the appliance contains following text install it in accordance with Diagram 1 below:

Water Heater and Controller installation configurations

If the appliance is marked to state that it delivers water not exceeding 50°C, local regulations may permit it's installation without a Temperature Limiting Device. Installations without a Temperature Limiting Device are shown in Diagram 1.

If the appliance is NOT marked to state that it delivers water not exceeding 50°C, or your local regulations require installation with a Temperature Limiting Device then install the appliance in accordance with Diagram 2.

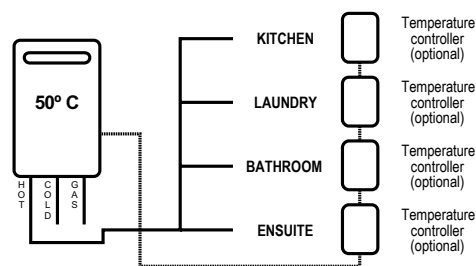

Diagram 1. 50° C Appliance

If the front cover of the appliance does NOT contain the above text install it in accordance with Diagram 2:

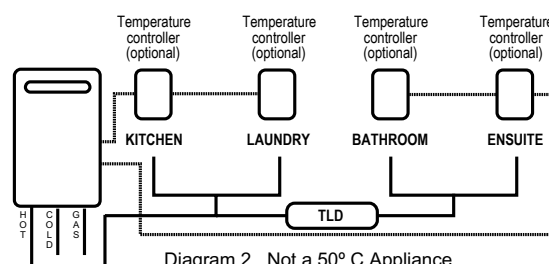

Diagram 2. Not a 50° C Appliance
Note: TLD = Temperature Limiting Device.

IMPORTANT: If the appliance is to deliver water primarily for the purposes of personal hygiene in an early childhood centre, primary or secondary school, nursing home or similar facility for young, aged, sick or disabled persons as defined in AS/NZ3500.4 a Temperature Limiting Device (TLD), such as a Tempering Valve, may be required even if the appliance is set to 50° C or less. For these types of applications contact Rinnai.

Connecting remote control cables



Do not attempt to connect the remote control cable terminals to the appliance with the power on.
RISK OF ELECTRICAL SHOCK.

Connecting One or Two Controllers

1. Isolate the power supply
2. Remove the front cover from the Appliance (4 screws) fig. 1.
3. Thread the cable(s) through the cable access hole at the base of the appliance.
4. Connect the spade connectors to the terminals marked "Remote Control" on the printed circuit board (fig. 2). Polarity is not important. Either wire colour can be connected to either terminal.
5. Replace cover of the Appliance. Ensure that the screw with the star washer is placed at the bottom right hand corner for earthing purposes.

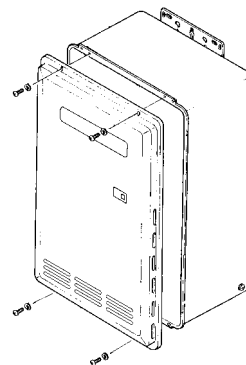

fig.1.

Connecting Three Controllers

6. Isolate the power supply
7. Remove the front cover from the Appliance (4 screws) fig.1.
8. Cut the spade connectors from 2 of the controller cables to be connected to the appliance (4 spade connectors should be cut off) and discard. Connect the wires from these two cables and terminate into two new spade connectors as shown in fig.3. Spade connectors are available from your local electrical component retailer.
9. Thread the 3 cables through the cable access hole at the base of the appliance. Connect the 4 spade connectors to the terminals marked "Remote Control" on the printed circuit board (fig.2). Polarity is not important. Either wire colour can be connected to either terminal.
10. Replace cover of the Appliance. Ensure that the screw with the star washer is placed at the bottom right hand corner for earthing purposes.

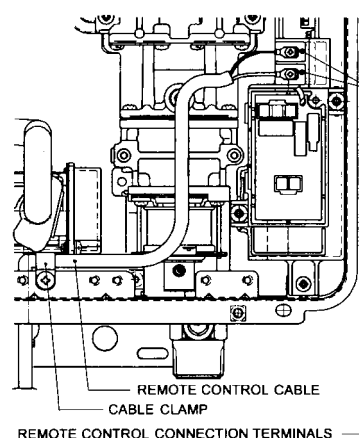

fig.2.

Connecting Four Controllers

11. Isolate the power supply
12. Remove the front cover from the Appliance (4 screws) fig 1.
13. Cut the spade connectors from all four controller cables to be connected to the appliance (8 spade connectors should be cut off) and discard. Connect the wires from two cables and terminate into two new spade connectors as shown in (fig. 3). Repeat for the remaining two cables. Spade connectors are available from your local electrical component retailer.
14. Thread the 4 cables through the cable access hole at the base of the appliance. Connect the 4 spade connectors to the terminals marked "Remote Control" on the printed circuit board (fig 2). Polarity is not important. Either wire colour can be connected to either terminal.
15. Replace cover of the Appliance. Ensure that the screw with the star washer is placed at the bottom right hand corner for earthing purposes.

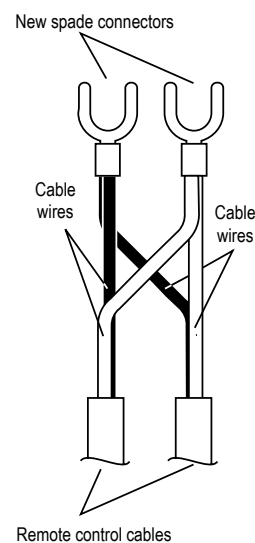

fig. 3

MC-91A Controller Programming

Question 1: Are four Controllers connected ?

IF YES: You will need to activate the fourth controller.

STEP 1:

For the Controller in the 'KITCHEN' only, press and hold the 'Transfer' and 'On/Off' buttons simultaneously (see fig. 1) until a 'beep' is heard (approximately 5 seconds).

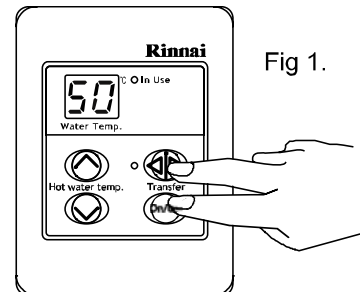

Fig 1.

STEP 2:

Check that the display on ALL FOUR controllers is lit and displaying a temperature when 'switched on'. If any ONE of the controller displays two dashes (see fig. 2) in the display repeat STEP 1.

This completes the activation procedure. Ignore Question 2.

IF NO: (You have three controllers or fewer), go to Question 2.

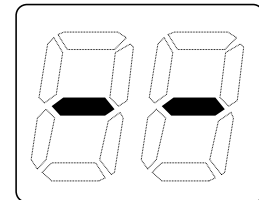

Fig 2.

Question 2: Is your water heater labelled "THIS APPLIANCE DELIVERS WATER NOT EXCEEDING 50° C IN ACCORDANCE WITH AS 3498" On the front cover ?

IF YES: No further action required.

IF NO: You will need to program the Kitchen controller to enable selection of temperatures higher than 50° C.

STEP 1:

For the controller in the KITCHEN only, press and hold the 'Transfer' and 'On/Off' buttons simultaneously (see fig 1.) until a 'beep' is heard (approximately 5 seconds).

STEP 2:

When the controller fitted in the KITCHEN is switched on, it should be possible to select temperatures higher than 50° C. If not, repeat Step 1.

Note:

- If the kitchen controller is replaced, repeat STEP 1 above for the replacement controller
- If the kitchen controller is swapped with another controller (for example, the controller fitted in a bathroom), repeat STEP 1 for the controller moved from the kitchen to the bathroom. Then perform STEP 1 for the controller moved from the bathroom to the kitchen.

6. Cutaway Diagram

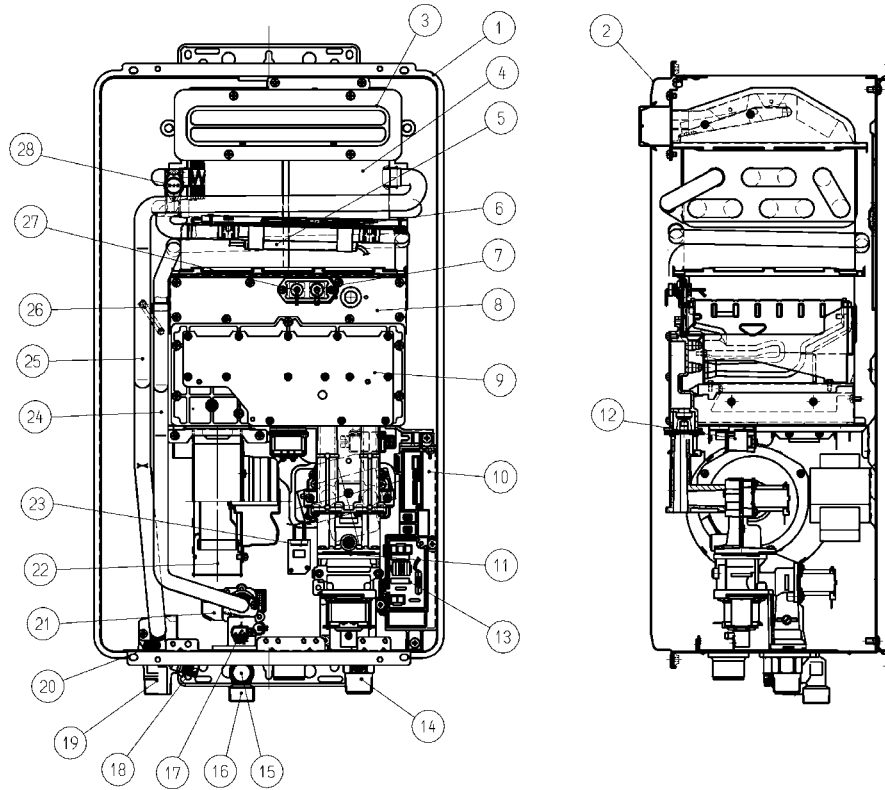

NO.	NAME	MATERIAL
1	CASING ASS'Y	HOT-DIPPED ZINC-COATED STEEL SHEET
2	FRONT PANNEL ASS'Y	STEEL SHEET
3	FLUE OUTLET	STAINLESS STEEL
4	HEAT EXCHANGER	COPPER
5	ANTI-FROST HEATER	(-AK, ZK ONLY)
6	THERMAL FUSES	
7	FLAME ROD	
8	COMBUSTION CHAMBER FRONT PLATE ASS'Y	HOT-DIPPED ALUMINUM COATED STEEL SHEET
9	MANIFOLD ASS'Y	ALUMINUM CASTING
10	P.C.B.	
11	GAS CONTROL ASS'Y	ALUMINUM CASTING
12	IGNITER	
13	SURGE PROTECTOR	
14	GAS CONNECTION	ALUMINUM CASTING
15	WATER FILTER ASS'Y	
16	WATER INLET	BRASS
17	WATER FLOW SENSOR	
18	PRESSURE RELIEF VALVE	BRASS
19	HOT WATER OUTLET	BRASS
20	OUTGOING WATER THERMISTOR	
21	WATER FLOW CONTROL DEVICE	
22	COMBUSTION FAN	
23	FROST SENSING SWITCH	(-AK, ZK ONLY)
24	WATER CONNECTING PIPE	COPPER
25	WATER CONNECTING PIPE	COPPER
26	BY-PASS PIPE	COPPER
27	ELECTRODE	
28	OVERHEAT SWITCH	

7. Operational Flow Chart

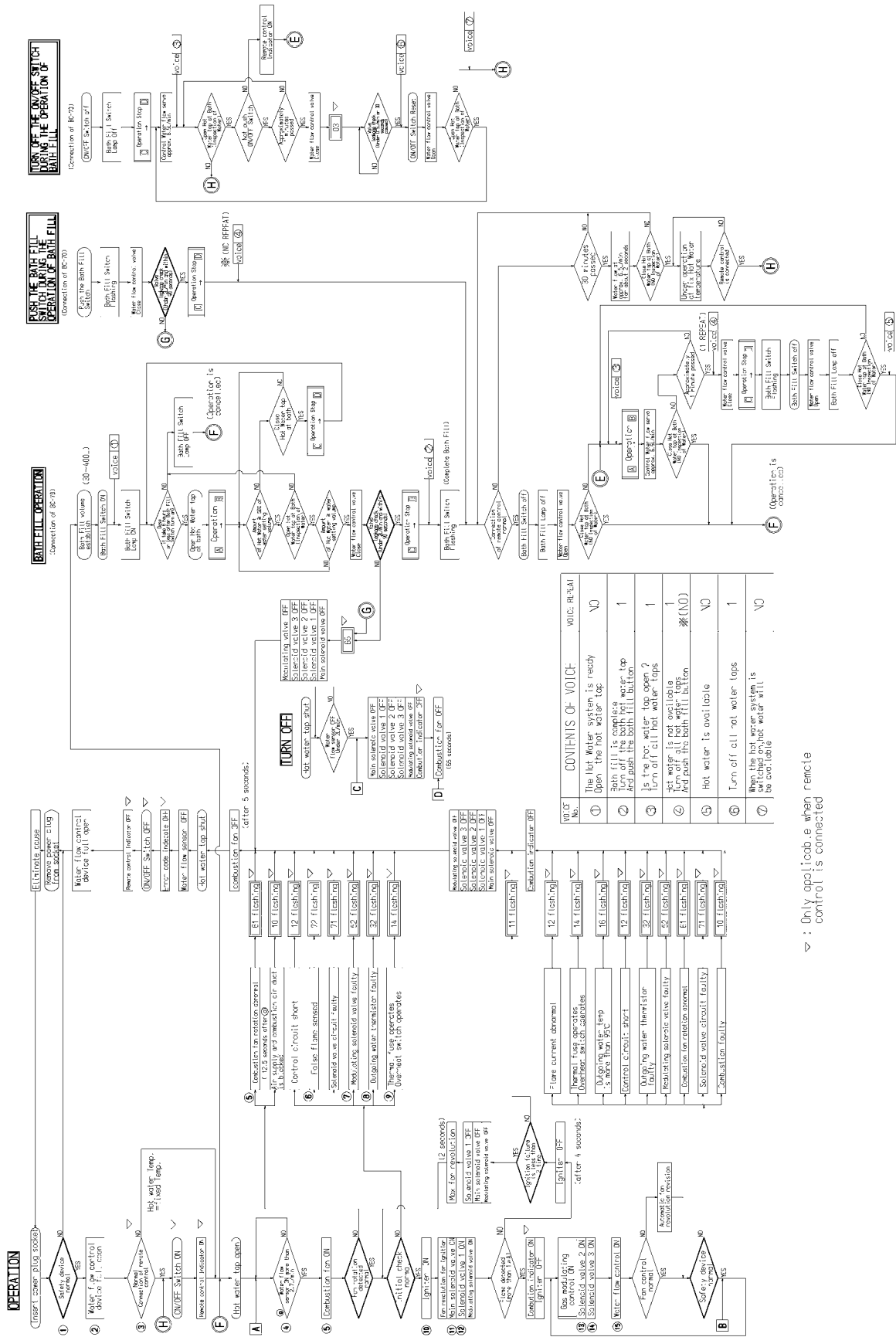

▽ : Only opo1.cob.e when remote control is connected

8. Operation Principles

REU-V2626W

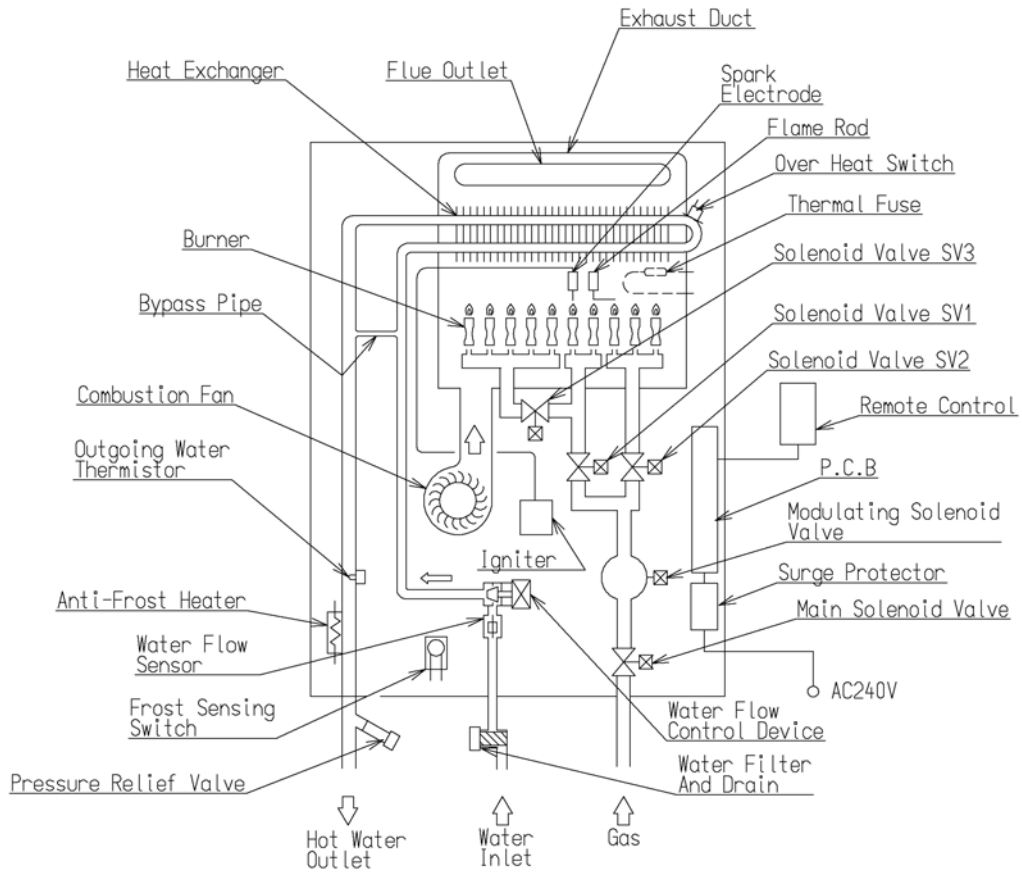

REU-V2632WC

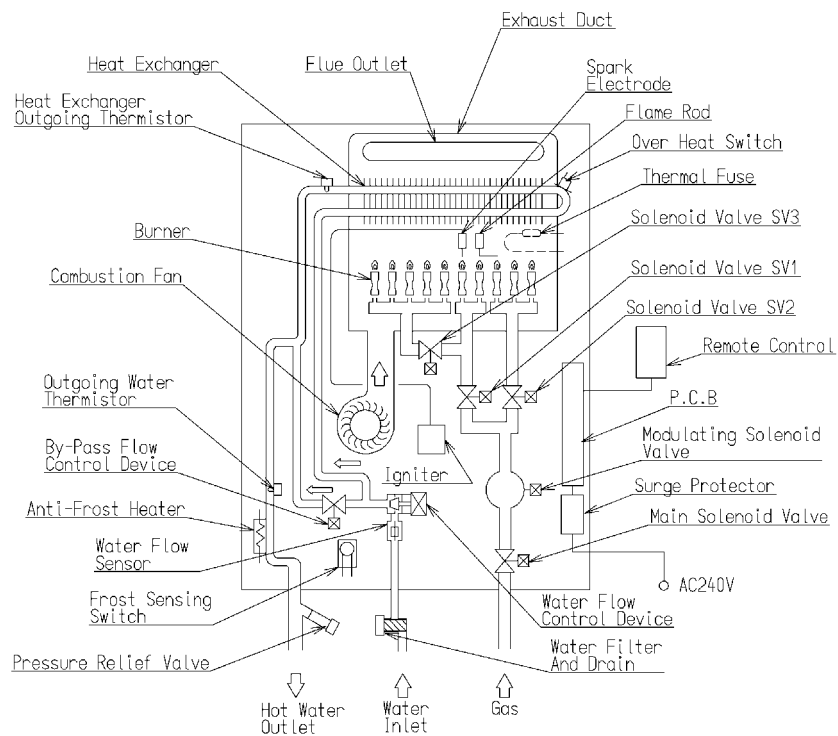

Hot Water Operation

1. Ignition

- Activate controllers (if fitted) and open the hot water tap (for full details regarding operation of controllers refer to the 'How To Use Your Water Heater' booklet).
- When water flows through the unit, the water flow sensor rotates and sends an electrical 'pulse' signal to the Printed Circuit Board (PCB). This signal is proportional to the water flow rate.
- The PCB sends electrical current to the combustion fan motor causing it to turn. The fan motor sends an electrical pulse signal to the PCB. If fan rotation is OK, the main solenoid and changeover solenoid valves open as required, the spark generator activates and the spark electrode ignites the burner.

2. Water Temperature / Flow Control / Volume Control

- The PCB will automatically control operation of the internal components to achieve the programmed temperature. When a high temperature rise is required, the PCB may cause the Water Flow Servo to close partially resulting in a lower flow rate to achieve the programmed temperature. This is a necessary operational feature of the unit.
- When operating in 'Bath Fill' mode, the signal from the water flow sensor is also used by the PCB to compute the volume of water that has been passed through the unit at any instant whilst the bath is filling.

3. Shut Down

- When operating in 'Bath Fill' mode, the PCB causes the Water Flow Servo to close when the programmed Bath Fill volume has passed through the unit. Alternatively, flow is stopped when the user closes the hot water tap.
- When water flow stops, the water flow sensor stops rotating and the pulse signal to the PCB stops. The PCB then causes the main solenoid and solenoid valves to close and the burner is extinguished. The combustion fan will continue to operate for some time to purge the combustion chamber.

9. Main Components

1) Printed Circuit Board

- The Printed Circuit Board controls all operational functions including Air Supply Control, Gas Control, Water Flow Measurement, Water Flow Control, Combustion System and all sensors and safety devices.

2) Gas Flow Control

- During normal operation, the PCB keeps the main solenoid valve open whilst there is flow through the unit and the burner needs to be lit.
- Gas flow rate is controlled by the modulating valve assembly and three changeover solenoid valves to always ensure constant outlet water temperature, regardless of flow rate or incoming water temperature.
- The modulating valve is electronically controlled by the PCB using signals from the water flow sensor, water flow control device, bypass flow control device, water temperature thermistors and combustion fan speed sensor. The modulating valve directs gas to the three changeover solenoid valves.
- The three changeover solenoid valves direct gas to each of the three burner banks independently. Any one, two or all of the solenoid valves may be open during operation.
- Gas flow is modulated between 16 and 199 MJ/hr by a combination of the modulating valve and changeover solenoid positions.
- The maximum gas rate is predetermined and the appliance cannot be overloaded when correctly installed.

3) Water Flow Control

- Water flow is detected by a turbine coupled to a magnetic pulse generating device. The magnetic pulses are detected and counted by the PCB. The PCB calculates the exact water flow from the frequency of pulses generated by the turbine, as well as the volume of water that has passed through the unit at any instant during 'Bath Fill' operation. A minimum flow rate of 2.4 l/min. is required for the burner to ignite.
- Water flow control is achieved through the use of servo driven water flow and bypass valves. Both servo motors are controlled by the PCB. The 'Water Flow Valve' restricts the flow of water into the heat exchanger assembly if the programmed temperature cannot be achieved. Also, when the Bath Fill function is activated, flow of water is stopped when the bath is full. During normal operation, cold water from the inlet valve is mixed with hot water from the heat exchanger outlet.
- For V2632WC, the 'Bypass Valve' mixes the correct proportion of cold and hot water to ensure accurate hot water delivery temperature over the available range of flow rates. The water flow and bypass valves are a combined assembly on the cold water inlet of the appliance.

4) Air Supply Control

- Air for combustion is supplied by a centrifugal fan driven by a variable speed DC motor. The voltage to the motor is determined by the PCB based on water flow, delivered water temperature and programmed water temperature. The actual fan speed is monitored by a magnetic pulse counter. This counter emits a signal to the PCB. From the voltage supplied to the DC motor and the fan speed signal, the PCB determines whether an error condition exists with the fan.

5) Combustion System

The combustion chamber is housed within the heat exchanger assembly and comprises:

- A three chamber aluminium alloy manifold with a total of 44 integral injectors, arranged in two rows of twenty two. The middle chamber houses eight injectors, the left chamber, twelve, and the right chamber, twenty four injectors. Gas flow to each chamber is controlled by an electronic solenoid valve (refer 'Gas Flow Control' above).
- A burner assembly comprising twenty two identical modular stainless steel bunsen burners secured by an aluminised steel framework. The manifold is attached to the front of the burner module. Each bunsen burner is supplied by two injectors.
- A combustion chamber. Integrated into the combustion chamber front panel are the flame rod and two ignition electrodes.

10. Time Charts

Normal Combustion - V2626W

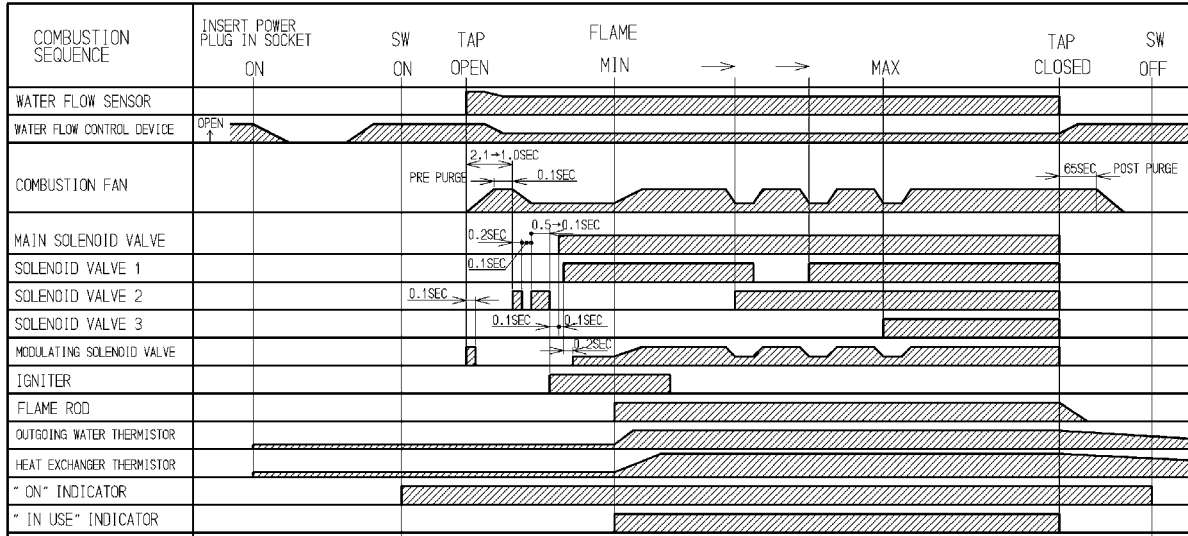

Mis-ignition / Flame Failure - V2626W

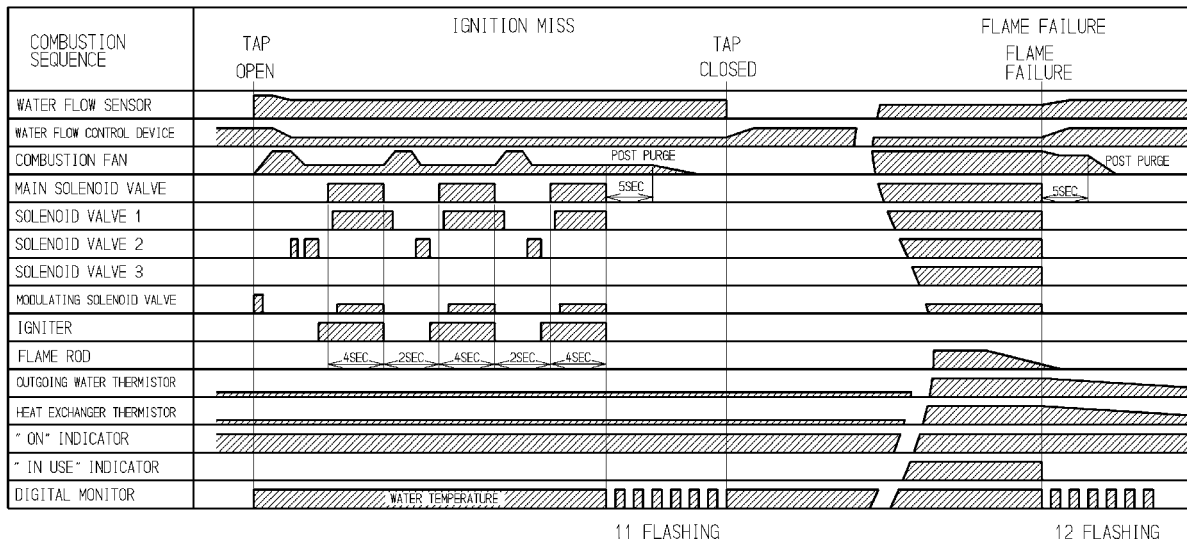

Abnormal Pre-Purge (Air Supply/Exhaust Blockage) - V2626W

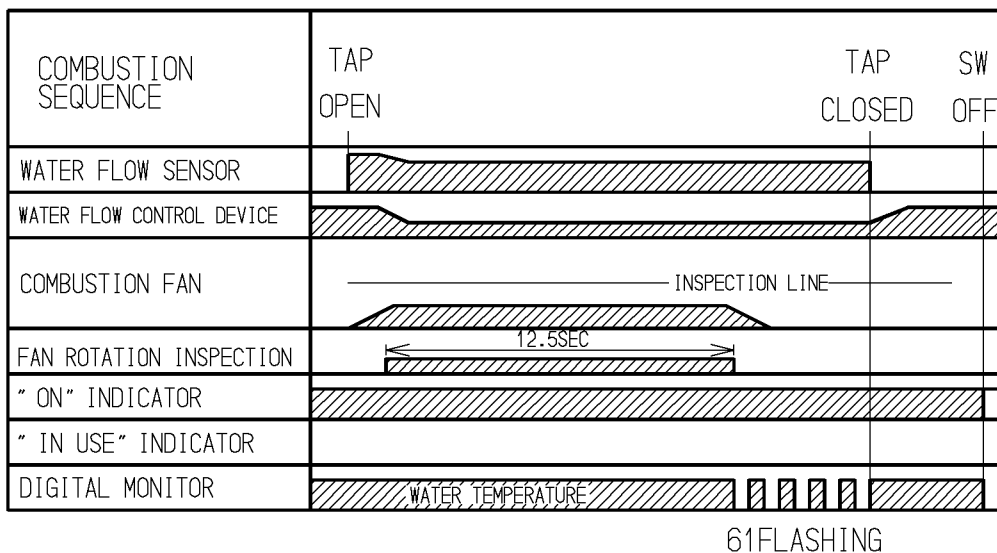

11. Wiring Diagram



REU-V2626W

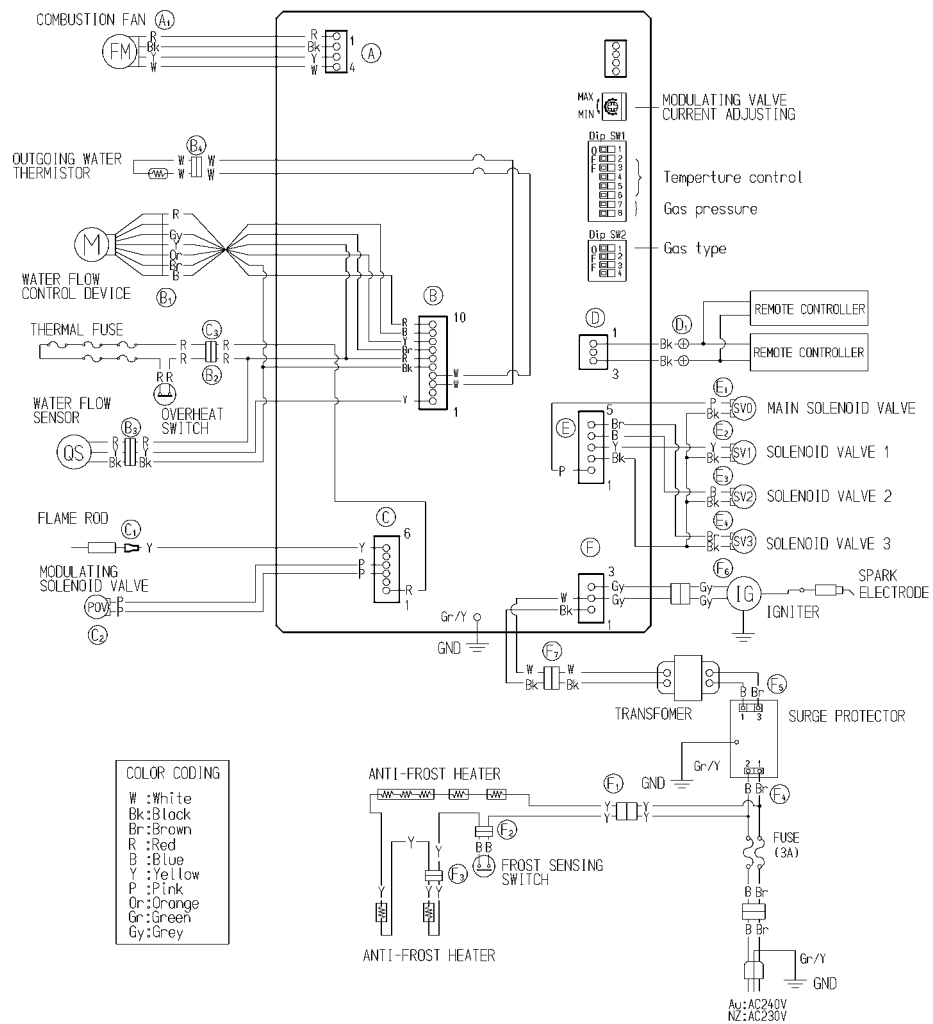

12. Dip Switch Settings

WARNING: Dip Switch settings must only be changed by an authorised person.

Dip Switch Settings REU-V2632W, REU-V2632WC & REU-V2626W

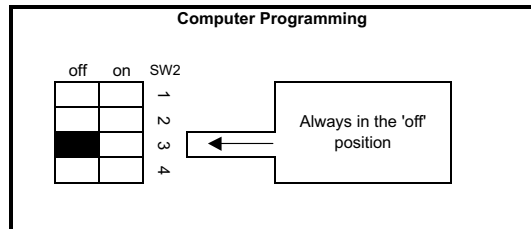
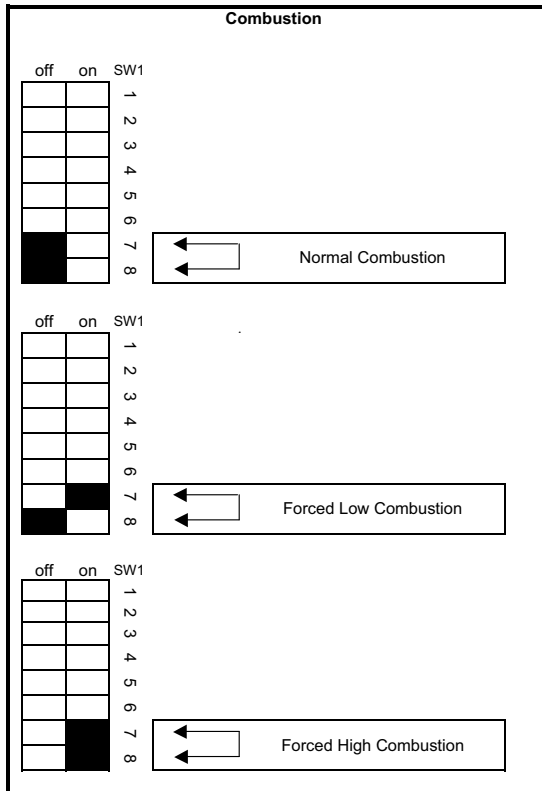
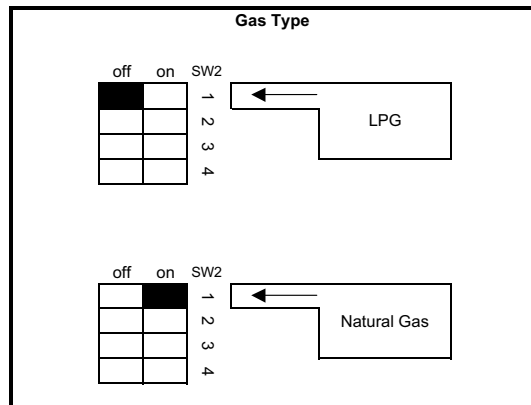
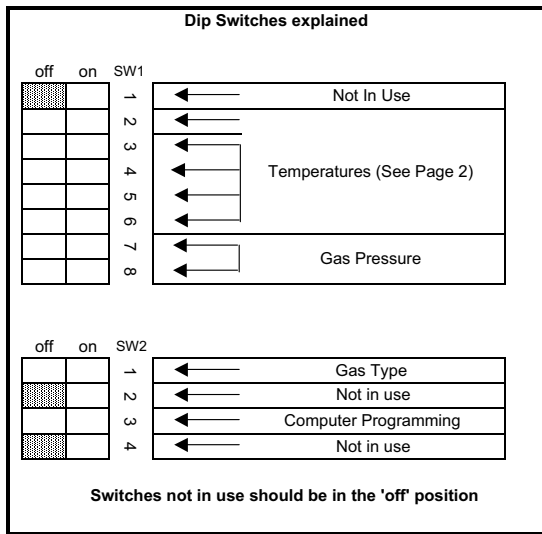

Dip Switches explained:

REU-V2632W, REU-V2632WC, REU-V2626W Temperature Settings

With or without remotes

off	on
SW1	
2	
3	
4	
5	
6	

40

off	on
SW1	
2	
3	
4	
5	
6	

43

off	on
SW1	
2	
3	
4	
5	
6	

50

off	on
SW1	
2	
3	
4	
5	
6	

55

With remotes

off	on
SW1	
2	
3	
4	
5	
6	

60

off	on
SW1	
2	
3	
4	
5	
6	

65

off	on
SW1	
2	
3	
4	
5	
6	

75

Note (1) : If remote(s) accidentally disconnected, units revert to a 'pre set' temperature of 55 C.

Legend (Black section indicates position of switch)

off	on

off	on

Without remotes

off	on
SW1	
2	
3	
4	
5	
6	

60

off	on
SW1	
2	
3	
4	
5	
6	

65

off	on
SW1	
2	
3	
4	
5	
6	

75

off	on
SW1	
2	
3	
4	
5	
6	

85°C*

*Note: ONLY models REU V2632WC and REU V2632FFUC can be converted to 85°C. Unit must be specially converted by Rinnai personell to delivery water at 85 C.

Dip Switch Settings using Preheat Loop Smart Start

SW No.	Item	OFF	ON
1	Vacant	Vacant	
2	Temp. setting	※See table 1	
3			
4			
5	Reserved	Reserved	
6	Reserved		
7	Preheat factor	0.80	0.90
8	Pump activation	Pump Off	Pump Run

Table 1
Temp. setting SW
SW No.

2	OFF	50	ON	43	OFF	55
3	OFF		OFF		ON	
4	OFF		OFF		OFF	

} For continuous System

13. Fault Finding



If there is a fault with the appliance, and controllers are installed, a numerical fault code may appear on the digital display controller. If controllers are not installed, one may be fitted to find out the fault code. Fault finding without controllers (and thus fault codes) is possible but more time consuming.

To diagnose and rectify faults, the **Fault Finding Table** is used as illustrated below:

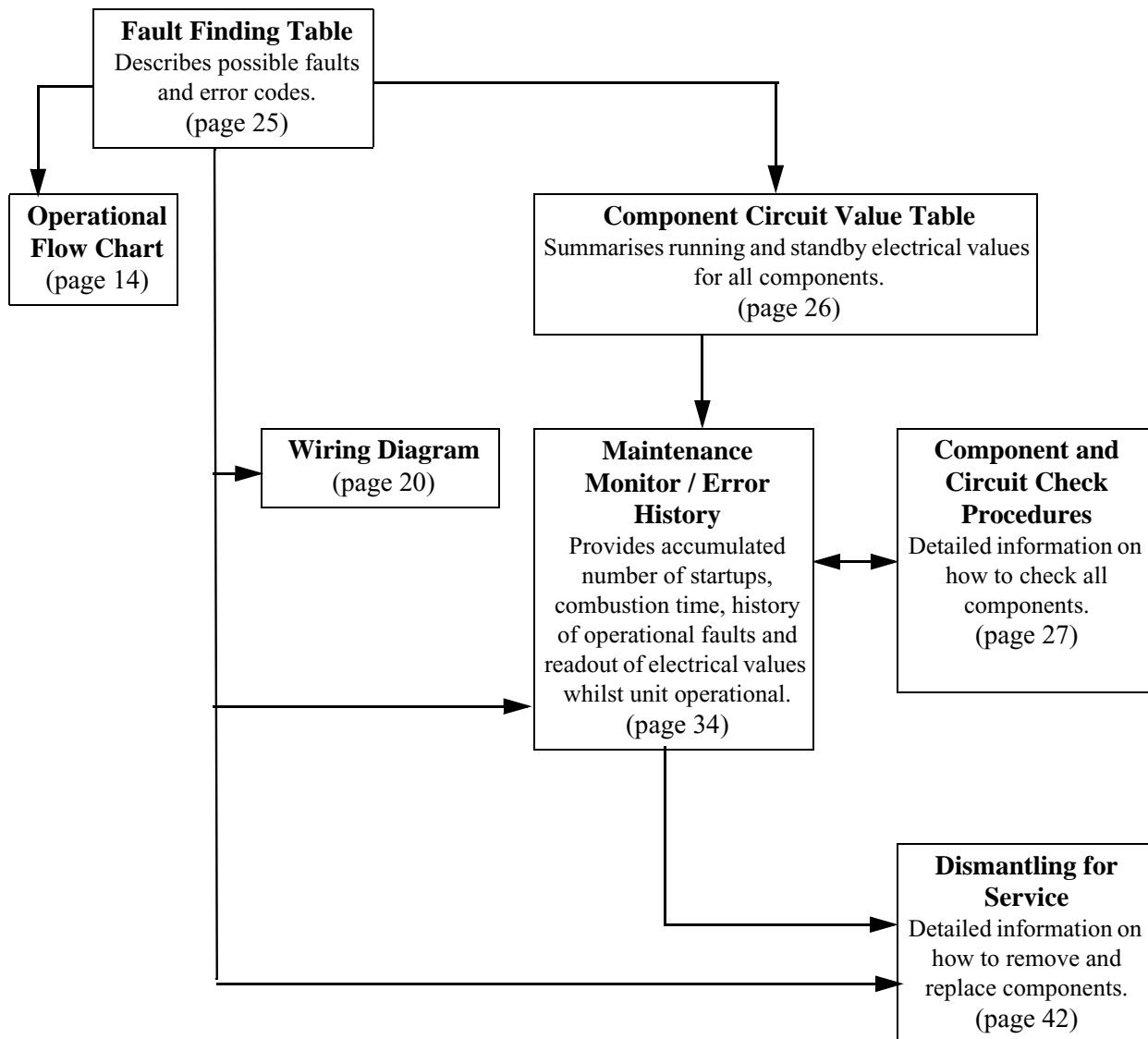

Fault Finding Table

Code on Controller	Fault	Table	Action
03	Power interruption during Bathfill. Water will not flow when power restored.		1. Turn off all hot water taps. 1. Press the ON/OFF button on a controller twice.
10	Combustion fan current too high. Unit operates, then stops.	F	1. Check blockage of air intake/flue outlet. 2. Check combustion fan.
11	No ignition. Unit stops without flame igniting	C	1. Check gas supply 2. Check sparker unit 3. Check gas valves
12	Flame Failure / Earth Leakage		1. Check gas supply 2. Check flame rod 3. Check earth wire lead 4. Check remote control
14	Thermal fuse and/or overheat switch activated. Unit operates, then stops.		1. Check thermal fuse 2. Check overheat switch IMPORTANT- If thermal fuse or overheat switch were faulty : a. Check heater for damage b. Confirm "Gas Type" and "Combustion" dip switch settings (page 22). c. Confirm test point pressures (page 36).
16	Over temperature warning. Unit operates, then stops.		1. Confirm "Gas Type" and "Combustion" dip switch settings (page 22) 2. Confirm test point pressure (page 36)
		C	3. Check gas valves
		D	4. Check water flow sensor
		B	5. Check water flow servo
		A	6. Check heat exchanger outlet temperature thermistor 7. Check hot water outlet temperature thermistor
32	Outlet water thermistor flow	A	Check hot water outlet thermistor
33	Heat exchanger thermistor error	A	Check heat exchanger thermistor
52	Modulating solenoid valve fault. Unit stops without flame ignition.	C	Check modulating solenoid valve
61	Combustion fan rotation error	F	Check combustion fan
65	Water flow control device error. Water flow is not controlled. Water temperature too low.	B	Check water flow servo
71	Solenoid valve circuit error. Unit does not operate.	C	Check gas valves
72	Flame rod circuit error. Unit does not operate.		Check flame rod
-	Appliance does not operate at all. No display on the remote controllers (if fitted).		1. Check power cord plugged in and supply turned on. 2. Check power supply voltage. 3. Check electrical fuse. 4. Check transformer.
		C	5. Check gas valves
			6. Check sparker unit. 7. Check earth leads and connections. 8. Check for short circuits. 9. Check remote controller(s) - if fitted.
-	No combustion despite remote control indicating that combustion is occurring - if remote controller(s) fitted)	D	1. Check water flow sensor.
			2. Check flame rod.
		A	3. Check heat exchanger outlet thermistor. 4. Check hot water outlet thermistor.
		F	5. Check combustion fan.
			6. Check the sparker unit.
		C	7. Check gas valves.
			8. Check thermal fuse.
			9. Check overheat switch.
			IMPORTANT - If thermal fuse or overheat switch were faulty: a) check heater for damage; b) confirm "Gas Type" and "Combustion" dip switch settings; c) confirm test point pressure.
-	Combustion stops during operation.		1. Check gas supply 2. Check flame rod 3. Check earth leads and connections.
-	Cannot adjust the hot water temperature via the controller(s) - only if controller(s) fitted.	A	1. Check hot water outlet thermistor. 2. Check heat exchanger outlet thermistor.
		C	3. Check gas valves
		B	4. Check water flow servo.
		E	5. Check bypass servo. (REU-V2632WC only)
-	Anti-frost heater does not operate.	G	1. Check anti-frost heater components 2. Check frost sensing switch

14. Component Circuit Value Table

Table Reference	Component	Measurement Point		Normal Value	A Note
		CN	Wire Colour		
	Surge Protection	F ₅	B-Br	AC207~264V	
B	Water Flow Control Device	B ₂	R-B	DC11~13V	Operate Electricity
			Gy-Or	DC11~13V	Control Electricity
			Gy-Y	Below DC1V (Limiter On)	Full Open Position
				DC4~6V (Limiter Off)	
			Gy-Br	Below DC1V (Limiter On)	Full Close Position
DC4~6V (Limiter Off)					
E	By-Pass Flow Control Device (REU-V2632WC Only)	G ₁	Br-W Or-W	DC2~6V	Operate Condition
			Y-W R-W GND	15~35Ω	
	Remote Control	D ₁	Bk-Bk	DC11~13V	
D	Water Flow Sensor	B ₄	R-Bk	DC11~13V	On 2.7L/min (30Hz) Over 1800 PULSE/min Off 2.0L/min (20Hz) Below 1200 PULSE/min
			Y-Bk GND	DC4~7V (Pulse 17~460Hz)	
F	Combustion Fan	A ₁	R-Bk	DC6~45V	
			Y-Bk	DC11~13V	
			W-Bk GND	DC5~10V (33~400Hz)	
	Flame Rod	C ₁	Y-BODY EARTH	AC5~150V	After Ignition
			Y-FLAME ROD	Over DC1μA	Flame Condition
C	Modulating Valve	C ₂	P-P	DC2~15V 67~81Ω	
A	Outgoing Thermistor Heat Exchanger Outgoing Thermistor (REU-V2632WC Only)	B ₄	W-W	15° C... 11.4 ~ 14.0kΩ	
		B ₅		30° C... 6.4 ~ 7.8kΩ 45° C... 3.6 ~ 4.5kΩ 60° C... 2.2 ~ 2.7kΩ 100° C... 0.6 ~ 0.8kΩ	
	Thermal Fuse	B ₃	R-R	Below 1W	
		C ₃			
	Igniter	F ₆	Gy-Gy	AC90~110V	
C	Main Solenoid Valve	E ₁	P-Bk	DC80~100V 1.7~2.1kΩ	
	Solenoid Valve 1	E ₂	Y-Bk	DC80~100V 1.7~2.1kΩ	
	Solenoid Valve 2	E ₃	B-Bk	DC80~100V 1.7~2.1kΩ	
	Solenoid Valve 3	E ₄	Br-Bk	DC80~100V 1.7~2.0kΩ	On Manifold
	Transformer	F ₅	B-Br	16~18W	
		F ₇	W-Bk	AC90~110V	
G	Valve Heater	F ₃		50~56kΩ	
	Valve Heater and Square Heater	F ₂	Y-Y	444~510kΩ	
		F ₃	Y-Y		

15. Component and Circuit Checks



1. Combustion Fan Circuit

Check the Motor

Check the combustion fan if the error indicator displays “61”.

Measure voltages between Black and Red of the PCB connector (A₁).

Normal: DC6~45V (when fan ON)

DC0V (when fan OFF)

If normal proceed to check the rotation sensor

Faulty: Replace PCB

Check for the Fan Rotation Sensor

a.) Measure voltages between Black and Yellow of connector (A₁).

Normal: DC11~13V

If normal proceed to b.).

Faulty: Replace PCB.

b.) Measure voltages between Black and White of connector (A₁).

Normal: DC5~10V

If normal proceed to Sparker Circuit 2.

Faulty: Replace Combustion Fan.

2. Sparker Circuit

a.) Measure voltages between Grey and Grey of connector (F₆).

Normal: AC90~110V

If normal, proceed to b.).

Faulty: Replace PCB.

b.) Disconnect connector (J₆) and measure resistance between both terminals of the sparker.

Normal: 1MΩ

If not sparking, adjust or replace ignition plug.

Faulty: Replace Sparker.

3a. Main Solenoid Valve (SV₀) Circuit

Check the main solenoid if error indicator “11” is displayed.

- a.) Disconnect Main Solenoid connector (E₁) and measure resistance between Pink and Black

Normal: 1.7~2.1kΩ

If normal, proceed to b.).

Faulty: Replace Main Solenoid.

- b.) Measure voltage between Pink-Black of Main Solenoid connector.

Normal: DC80~100V

If normal, proceed to Solenoid Valve SV₁ (E₂)

Faulty: Replace PCB.

3b. Solenoid Valve 1 (SV₁) Circuit

Check Solenoid 1 if error indicator “11” is displayed.

- a.) Disconnect Solenoid 1 connector (E₂) and measure resistance between Yellow and Black.

Normal: 1.7~2.1kΩ

If normal, proceed to b.).

Faulty: Replace Solenoid 1.

- b.) Measure voltage between Yellow and Black of Solenoid 1 connector.

Normal: DC80~100V

If normal, proceed to Solenoid Valve 2 (SV₂) Circuit

Faulty: Replace PCB.

3c. Solenoid Valve 2 (SV₂) Circuit

- a.) Disconnect Solenoid Valve 2 connector (E₃) and measure resistance between Blue and Black.

Normal: 1.7~2.1kΩ

If normal, proceed to b.

Faulty: Replace Solenoid Valve 2.

- b.) Measure voltage between Blue and Black of Solenoid Valve connector.

Normal: DC80~100V

If normal, proceed to Thermal fuse Circuit.

Faulty: Replace PCB.

3d.Valve Circuit

a.) Disconnect Solenoid connector (E₄), measure resistance between Brown and Black.

Normal: 1.7~2.0kΩ

If normal, proceed to b.).

Faulty: Replace Solenoid Valve 3.

b.) Measure voltage between Brown and Black of SV₃ connector.

Normal: DC80~100V

If normal, proceed to Modulating valve circuit.

Faulty: Replace PCB.

c.) Disconnect Modulating Valve fasten terminal and measure resistance between terminals.

Normal: 67~81Ω

If normal, proceed to b.).

Faulty: Replace Modulating Valve.

d.) Measure voltage between Pink and Pink of Modulating Valve fasten terminal.

Normal: DC2~15V

If normal, proceed to c.).

Faulty: Replace PCB.

e.) Check the gas secondary pressure change when set temperature on the remote control changes from 37 to 55°C.

Normal: If secondary pressure changes, go to Water Flow Servo Circuit.

Faulty: Replace Modulating Valve.

4. Flame Rod Circuit

Check flame rod.

Disconnect flame rod terminal (C₁), and re-operate.

“72” indicated:- Proceed to 3.

“72” is not indicated:- check for electrical leaks from the flame rod.

Measure resistance between flame rod terminal (C₁) and appliance earth.

Normal: >1MΩ

If normal, replace PCB.

Faulty: Replace flame rod.

a.) Remove the Flame Rod terminal (C₁) repeat operation procedure, if 72 is displayed again check the Hot water outlet thermistor.

If 72 is not displayed check current leakage from the Flame Rod.

b.) Measure voltage between body earth and Flame Rod terminal (C₁).

Normal: Voltage AC5~150V

If normal, replaced PCB

Faulty: Replace Flame Rod.

c.) Check if the Flame Rod is securely fitted.

Normal: replace the PCB

Faulty: Adjust the fitting of the Flame Rod

4. Earth Lead

Confirm the Earth Lead connection is secure (at round terminal), and check for broken or short circuits in the lead.

If normal, check other possible causes for flame failure (is gas valve open?, is the filter blocked? etc.).

If faulty, tighten the earth lead, PCB, power cord and surge arrester.

5. Thermal Fuse Circuit

Check the Thermal Fuse.

Disconnect relay connector (F₁) measure resistance between Red and Red.

Normal: < 1Ω

If normal, replace PCB.

Faulty: Replace Thermal Fuse if after confirming there is no damage to the appliance.

6. Overheat Switch Circuit

Measure resistance between Overheat Switch terminals.

Normal: < 1Ω

If normal, replace PCB.

Faulty: Replace Overheat Switch.

Note: If Thermal fuse or Overheat Switch were faulty.

- a.) Check heater for damage
- b.) Confirm gas type and combustion dipswitch settings
- c.) Confirm test point pressure.

7. Water Flow Sensor

a.) Measure voltage between Red - Black of relay connector (B₄).

Normal: DC 11~13V

If normal, proceed to b.

Faulty: Replace PCB.

b.) Measure voltage between Yellow - Black of relay connector (B₄).

Normal: DC 4~7V

If normal, proceed to 2).

Faulty: Replace water flow sensor.

Note: For controller readout of water flow whilst operational refer maintenance monitor. (Chapter 17 No. 1).

8. Water Flow Servo Circuit

a.) Disconnect relay connector (B₂), and measure voltage between Red and Blue on water flow servo.

Normal: 10~30Ω

If normal: proceed to b.).

Faulty: Replace Water Flow Servo and Water Flow Sensor.

b.) Disconnect relay connector (B₂), and measure voltage between Orange (+) and Grey (-) on PCB unit side.

Normal: DC11~13V

If Normal: proceed to c.).

Faulty: Replace PCB unit.

c.) Measure voltage between Brown and Grey with relay connector (B₂) connected (with no water flowing, water flow servo fully open).

Normal: < DC4~6V

Faulty: Replace Water Flow Servo and Water Flow Sensor.

d.) Measure voltage between Yellow and Grey with relay connector (B₂) connected (with no water flowing, water flow servo fully open).

Normal: < DC1.0V

Faulty: Replace Water Flow Servo and Water Flow Sensor.

9. Heat Exchanger Outlet Thermistor Circuit

Check Heat Exchanger Thermistor if error code “33” is displayed.

Disconnect relay connector (B₆) and measure resistance between White -White.

Circuit break: Resistance >1MΩ

Short circuit: Resistance > 1 Ω

Normal: Check Heat exchanger outlet thermistor

Faulty: Replace heat exchanger outlet thermistor.

Note: For controller readout of thermistor temperature whilst operational refer maintenance monitor.

10. Hot Water Outlet Thermistor Circuit

Check Hot Water Thermistor if error code “32” is displayed.
Disconnect relay connector (B₅) and measure resistance White - White.

When disconnected: Resistance > 1 MΩ

When short circuit: Resistance > 1 Ω

Normal: Check Heat Exchanger Outlet Thermistor.

Faulty: Replace hot water outlet thermistor.

Normal

Temp.	15°C	30°C	45°C	60°C
Resistance	11.4~14 kΩ	6.4~7.8 kΩ	3.6~4.5 kΩ	2.2~2.7 kΩ

Note: For controller readout of thermistor temperature whilst operational refer maintenance monitor. (Chapter 17, No. 2).

Disconnect relay connector (E₁) and measure resistance White-White.

11. Surge Protector

Check the fuse.

a.) Unplug the power plug.

b.) Check whether or not the fuse (3A) x 2 has blown by measuring the resistance.

Normal: <1Ω

If normal go to step Electrical Fuse 13.

Faulty: Replace fuse/s (3Ax2). Check for a short next time it's turned off.

12. Electrical Fuse

a.) Measure voltage between blue and brown on the connector (F₄)

Normal : AC 207~264V

If normal proceed to b.

Faulty: Check if voltage on the fuse terminal is AC207~264V

b.) Measure voltage between white and white on the (F₅).

Normal: AC207~264V.

Faulty: replace surge protector unit.

13. Transformer

Check for the transformer

a.) Measure the voltage between red and red on the transmission connector (F₅).

Normal: AC207~264V

If normal proceed to b.).

Faulty: Check if the voltage on fuse terminals is 207~264V.

b.) Measure the voltage of the connector on the PCB.

Normal: Between Brown and Grey AC 30~50V
Between Yellow and Grey AC 180~220V
If normal, proceed to c.).

Faulty: Replace transformer.

c.) Measure voltage between White and Black of connector (F) on PCB.

Normal: AC 90~110V
If normal, proceed to 4.

Faulty: Replace transformer.

Note) The above transformer voltages are measured while the appliance is in standby mode - not while it is operating.

14. Bypass Servo Circuit 15.

a.) Disconnect relay connector (G₁) and measure resistance.

Normal

CN	Wire Colour	Value
G ₁	Br - W O - W Y - W R - W ^{GND}	15~35Ω

If normal, proceed to b.).

Faulty: Replace PCB.

b.) Measure working voltage while relay connector (G₁) is connected.

Normal

CN	Wire Colour	Value
G ₁	Br - W O - W Y - W R - W ^{GND}	DC 2~6V

Faulty: Replace Bypass Servo.

15. Remote Control

Check the voltage between the 2-core remote control cable.

Measure the voltage between terminals on the remote control terminal (D₁).

Normal: DC 11~13V

If normal, replace the remote control after confirming that the cable hasn't been damaged or shorted.

Faulty: Because normal voltage is not given due a short circuit, despite the PCB being in normal state, check Water Flow Servo circuit.

If solution is not given from the above replace PCB.

16. Maintenance Monitor / Error History

This feature is available on appliances where a deluxe controller (MC70-2A or BC70-2A) is fitted, enabling service personnel to locate the error history and fault find operational appliances.

NB. Use only one controller, when accessing the maintenance information /error history, as two or more remote controls may cause incorrect operation.

To display Maintenance Information

1. With the controller in the "OFF" position press the Water Temperature "DOWN" (Cooler) button while holding the "ON/OFF" button to activate the maintenance monitor. Press the "ON/OFF" button a second time to set the controller in the "ON" mode. This feature can now be used with the appliance in operation.
2. The maintenance number will be shown in the Water Temperature display.
3. Data will be shown in the Clock display.
4. To select the required maintenance number, press the Water Temperature "UP" and "DOWN" buttons.

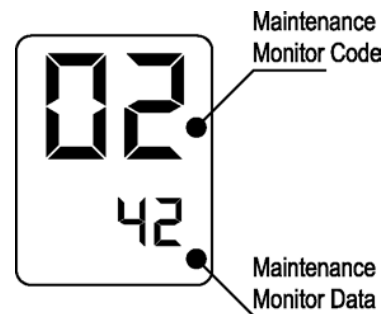

Display Monitor Contents			
No.	Contents	Units	Data Range
01	Water flow sensor recognition flow (Example 123 = 12.3L/min).	0.1L/min	0~400
02	Hot water Outlet thermistor temperature (Example 20 = 20°C)	°C	0~999
03	Hot water combustion time (Example 6 = 600 hours)	100 hours	000~999
04	Hot water operation frequency (Example 6 = 600 Operations)	100	0~999
05	Hot water fan frequency	Hz pulses/sec	0~999 *Note 1

***Note 1** Fan Frequency rpm Conversion
 $(rpm) = (Hz) \times 15$

06	Remote control connection	none	0 or 1 *Note 2
----	---------------------------	------	-----------------------

***Note 2** Remote Control Connections

	Bathroom Remote		Kitchen remote
Additional remotes			
" 0			" 1 "
	1		

Controls connected	Display
No	"0"
Yes	"1"

07	Water flow servo present recognising positioning	None	0~2 *Note 3
----	--	------	-------------

***Note 3 Water Flow Servo Positioning**

Servo Position	Open	Centre	Closed
Display	"1"	"0"	"2"

08	Inlet water temperature (PCB recognition value) (Example 25 = 25°C)	°C	0~999
09	Hot water fan current flow value (Example 6 x 10 = 60 mA)	10 mA	0~999
10	Bath fill amount (this counts the litres during bath fill operation).	Litres	0~999
11	Heat exchanger exit thermistor temperature (Example 55 = 55° C)	°C	0~999

To return to normal operation

- Press the ON/OFF button again while holding down the Water Temperature "DOWN" (Cooler) button.

(Hotter)

for error

isplayed in

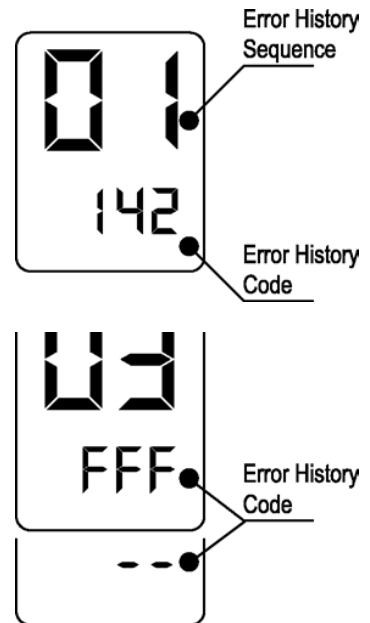

To return to normal operation.

- Press the ON/OFF button again while holding the Water Temperature "UP" (Hotter) button.
- This feature will automatically shut down after 3 minutes.

17. Gas Pressure Setting Procedure



The regulator on the Infinity is electronically controlled and factory pre-set. Under normal circumstances it **does not** require adjustment during installation. Perform this procedure only if the unit is not operating correctly and **all** other possible causes for incorrect operation have been eliminated.

- 1) Turn 'OFF' the gas supply
 - 2) Turn 'OFF' 240V power supply.
 - 3) Remove the front cover from the appliance.
 - 4) Check gas type switches (fig. 1) are in the correct position (dipswitch 1 of SW2 'ON' = NG 'OFF' = LPG).
- Note: 'ON' towards front, 'OFF' towards rear.**

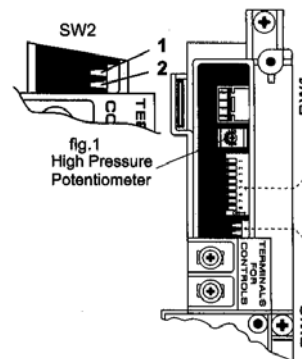

- 5) Attach pressure gauge to burner test point, located on the gas control. (fig. 2).
- 6) Turn 'ON' the gas supply.
- 7) Turn 'ON' 240V power supply.
- 8) If remote controllers are fitted, turn the unit 'ON' at the kitchen controller, select the maximum delivery temperature of 55°C and open a hot water tap fully. **(CAUTION: Ensure building occupants do not have access to hot water outlets during this procedure).**

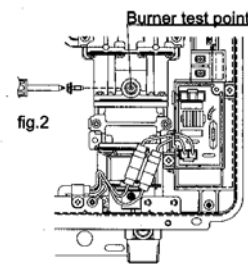

Pressure Setting Low	
N.G.	0.14 kPa
Prop.G.	0.22 kPa

Table 1.

- 9) Set the Infinity to 'Forced Low' combustion by setting No. 7 dipswitch of the (SW1) set of dipswitches to 'ON'. (fig. 3).

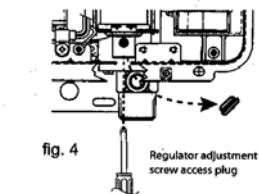

- 10) Check the burner test point pressure.
- 11) Remove rubber access plug and adjust the regulator screw on the modulating valve (fig. 4) as required to the pressure Table 1. Replace rubber access plug.

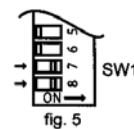

- 12) Set the Infinity to 'Forced High' combustion by setting both No. 7 and No. 8 dipswitches on the bottom (SW1) set to 'ON'. (fig. 5). Ensure maximum water flow.

Pressure Setting High	
N.G.	0.79 kPa
Prop.G.	1.15 kPa

Table 2.

- 13) Check the burner test point pressure.

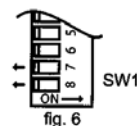

- 14) Adjust the high pressure Potentiometer (POT) on the Printed Circuit Board (PCB) as required to the pressure shown Table 2. (fig. 1).

- 15) **IMPORTANT:** Set dipswitches No's 7 and 8 on the bottom (SW1) set of switches to 'OFF' to return the appliance to 'Normal' combustion. (fig. 6).
- 16) Close hot water tap.
- 17) Turn OFF the gas supply and 240V power supply.
- 18) Remove pressure gauge, and replace sealing screw.
- 19) Turn 'ON' the gas supply and 240V power supply.
- 20) Operate unit and check for gas leaks at test point.
- 21) Replace the front cover of the appliance.

	<h1>Warning</h1> <p>DURING PRESSURE TESTING OF THE INSTALLATION ENSURE GAS COCK SITUATED BEFORE UNIT IS SHUT OFF. FAILURE TO DO SO MAY RESULT IN SERIOUS DAMAGE TO THE APPLIANCE AND POSSIBLE INJURY.</p>
---	--

18. Gas Conversion Procedure



<ol style="list-style-type: none"> ① Turn OFF main gas valve ② Disconnect 240V power supply ③ Remove Front Cover ④ Remove Remote Control 	
<p>Replacement of Manifold</p> <ol style="list-style-type: none"> ① Remove Flame Rod Connection terminal ② Pull off high tension lead 	
<ol style="list-style-type: none"> ③ Remove Manifold assembly <div style="display: flex; align-items: center;"> <div style="font-size: 3em; margin-right: 10px;">[</div> <div style="margin-right: 10px;">Screws (9)</div> <div style="margin-right: 10px;">Manifold - Gas Control (3)</div> <div style="margin-right: 10px;">Manifold - Burner (6)</div> <div style="font-size: 3em; margin-left: 10px;">]</div> </div> <p>Clean combustion deposits on the burner if necessary</p> 	
<ol style="list-style-type: none"> ④ Replace Manifold fit Gasket to Gas Control. <p>REU-V2626W For NG: U245-200-B 92092550 For Propane: U245-200-A 92092089 REU-V2632WC For NG: U245-200-C 92094317 For Propane: U245-200-A 92094309</p>	

⑤ Change Gas Type Switch on PCB

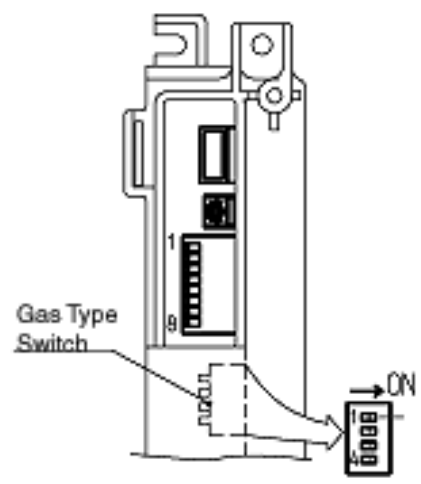

LPG	NG																
<table border="1"> <tr><td>□</td><td>1</td></tr> <tr><td>□</td><td>2</td></tr> <tr><td>□</td><td>3</td></tr> <tr><td>□</td><td>4</td></tr> </table>	□	1	□	2	□	3	□	4	<p>→ ON</p> <table border="1"> <tr><td>□</td><td>1</td></tr> <tr><td>□</td><td>2</td></tr> <tr><td>□</td><td>3</td></tr> <tr><td>□</td><td>4</td></tr> </table>	□	1	□	2	□	3	□	4
□	1																
□	2																
□	3																
□	4																
□	1																
□	2																
□	3																
□	4																

Pressure Setting

- ① Remove pressure test point sealing screw from gas control
- ② Connect digital manometer with test point

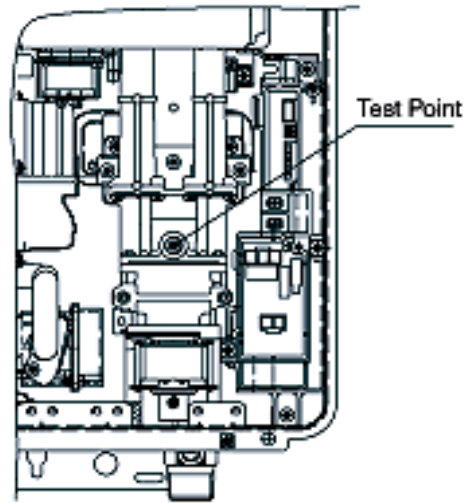

- ③ Turn ON 240V power supply
- ④ Turn ON remote controller switch
- ⑤ Turn ON main gas valve fully

- ⑥ Change Dipswitch No. 7 for low combustion
- ⑦ Turn ON outgoing water tap
- ⑧ Set pressure low with solenoid valve adjustment

	Low Capacity (k P a)
N. G.	0.14
Prop. G	0.22

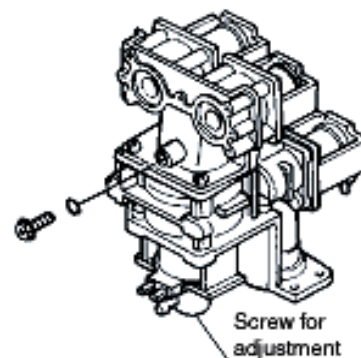
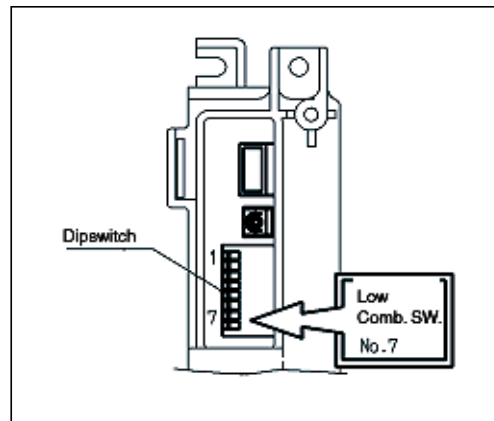

- ⑨ Change Dipswitch No. 7 & 8 to ON for high combustion.
- ⑩ Set high capacity pressure with adjustment volume on PCB

	High Capacity (k P a)
N. G.	0.79
Prop. G	1.15

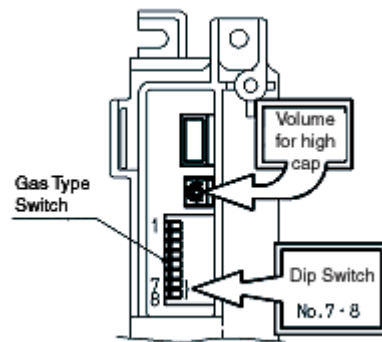

- ⑪ Return Dipswitch No. 7 & 8 to OFF position

- ⑫ Turn OFF outgoing water tap
- ⑬ Disconnect 240V power supply
- ⑭ Fit pressure test point sealing screw
- ⑮ Check leakage from gas control, manifold connection and pressure point sealing screw

- ⑯ Refit front cover
- ⑰ Turn ON 240V power supply

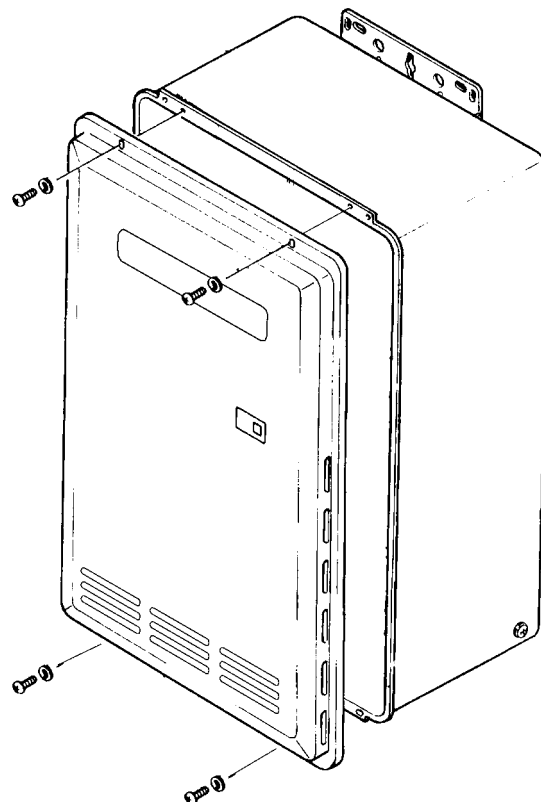

19. Dismantling for Service



240 Volt potential exposure. Isolate the appliance and reconfirm with a neon screwdriver or multimeter.

Item	Page
1. "Removal of the Front Panel"	43
2. "Removal of the PCB Unit"	43
3. "Removal of the Water Flow Sensor, Servo and Bypass Servo"	43
4. "Removal of the Bypass Servo -"	44
5. "Removal of Transformer"	44
6. "Removal of Sparker"	58
7. "Removal of the Manifold and Burner unit"	58
8. "Removal of the Gas Control"	58
9. "Removal of Flame rod and Spark plug"	59
10. "Removal of Outgoing Water Thermistor"	60
11. "Removal of Heat Exchanger Thermistor"	61
12. "Removal of Bypass Servo -"	47
13. "Removal of Anti Frost Switch"	47
14. "Removal of Anti Frost heater"	48
15. "Removal of the Fan Motor"	48
16. "Removal of Heat Exchanger"	49
17. "Removal of Thermal Fuse"	50

Unless otherwise stated, re-assembly is the reverse of dismantling.

IMPORTANT

For some areas of dismantling you may need to isolate any or all of the following:

- * Isolate gas supply.
- * Disconnect electrical supply from wall socket.
- * Isolate water supply.
- * Drain **all** water from appliance.

1) Removal of the Front Panel

- a. Remove four (4) screws.



2) Removal of the PCB Unit

- a. Remove the front panel. (Refer Item 1.)
- b. Remove two (2) PCB unit fixing screws and pull out forward.



3) Removal of the Water Flow Sensor, Servo and Bypass Servo

- a. Remove the front panel. (Refer Item 1.)
- b. Remove two (2) screws and locking plates located on the water supply pipe and bypass pipe. Pull bypass pipe and water supply pipe forward to clear servo valves. Ensure O-rings are not lost or damaged.

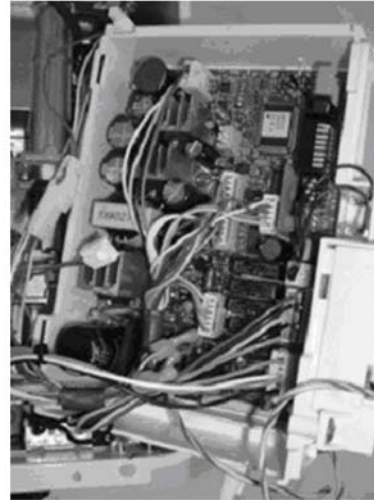

4) Removal of the Bypass Servo - REU-V2632WC - (HD200E) ONLY

- a. Remove two (2) screws from the water flow servo body, and pull the bypass servo out forwards. Ensure O-rings are not lost or damaged.



5) Removal of Transformer

- a. Remove PCB (Refer to 2)
- b. Remove 100 V harness and 2-pin connection

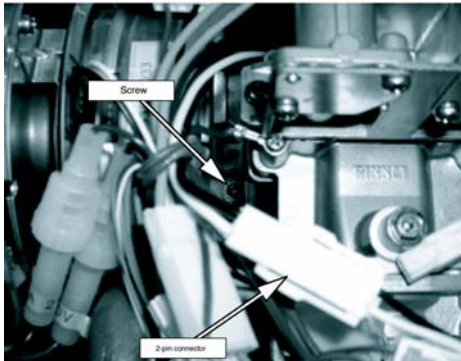

c. Removal Transformer

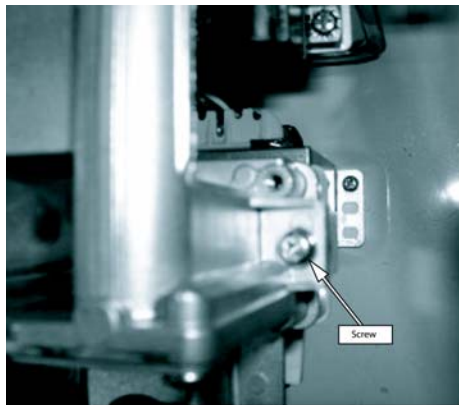

6) Removal of Sparker

- a. Remove sparker
- b. Remove 3 pin connector
- c. Remove high tension cord

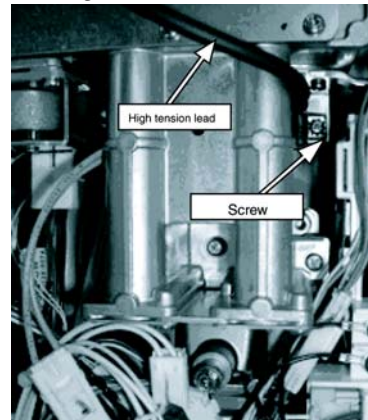

7) Removal of the Manifold and Burner unit

- a. Remove high tension cord and flame rod.
- b. Remove 2 pin connection of the solenoid valve
- c. Remove manifold.

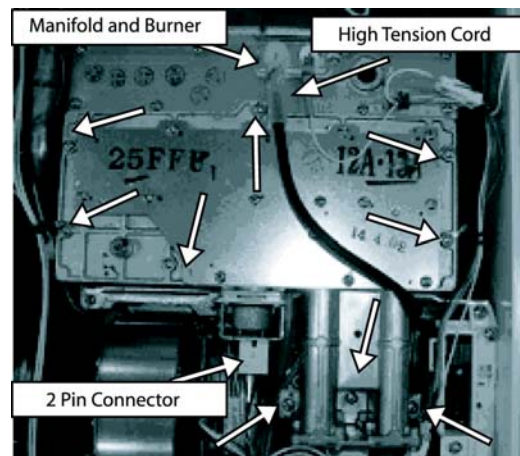

Manifold Assembly

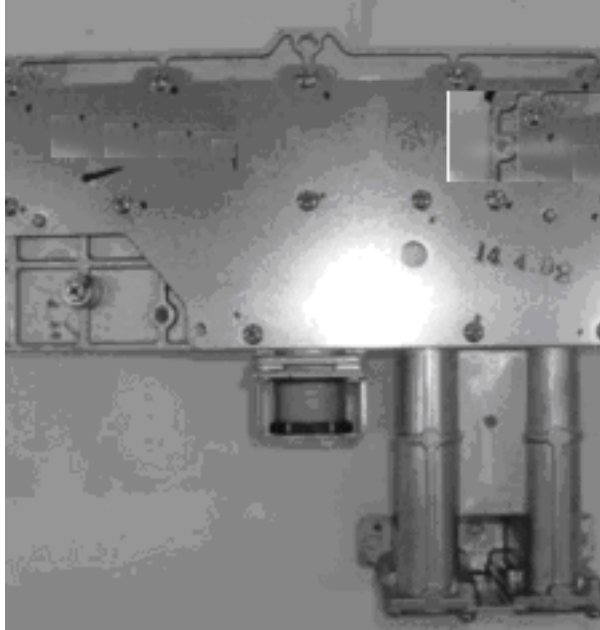

- a. Remove combustion chamber front panel.
- b. Remove burner unit.

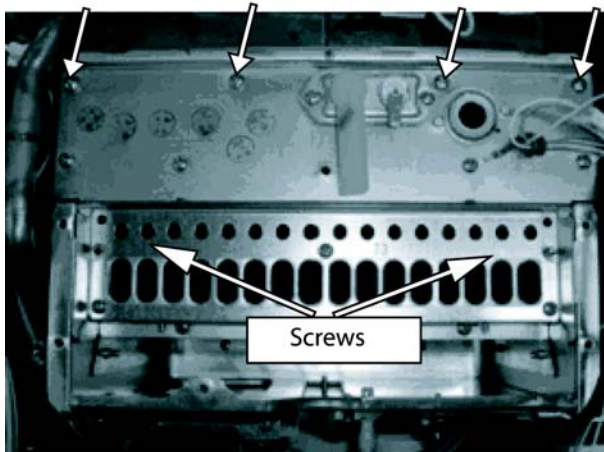

- c. Pull off burner unit

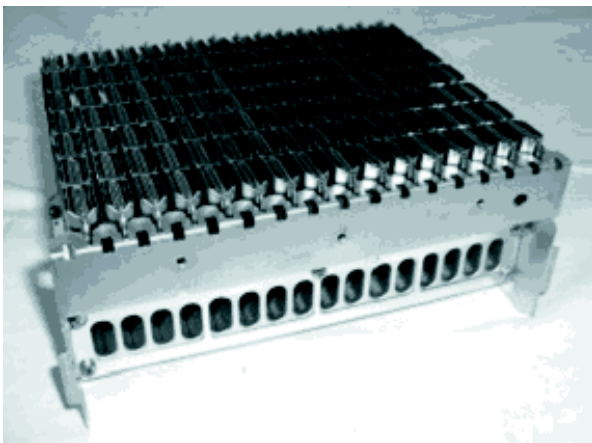

8) Removal of the Gas Control

- a. Remove manifold (refer to point 7)
- b. Remove back tube
- c. Remove gas connection.

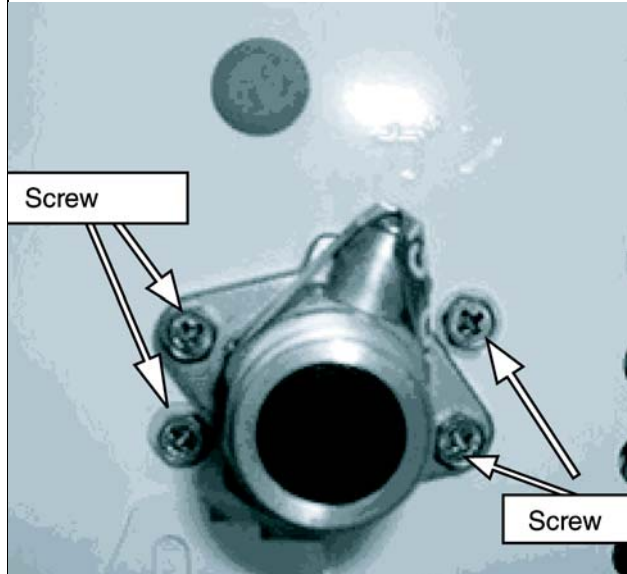

- a. Pull off connectors for gas control modulation valve and solenoid valve.

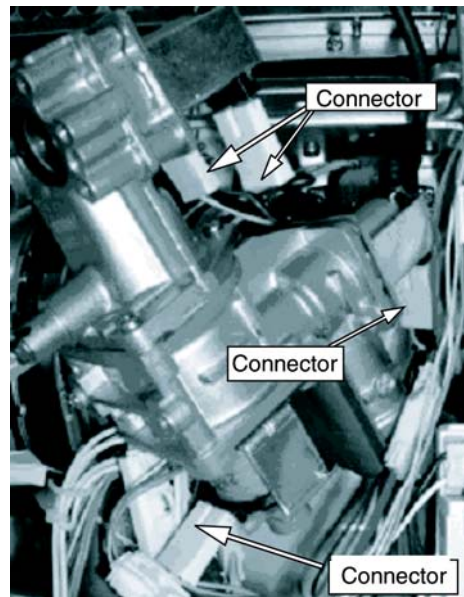

Gas Control



9) Removal of Flame rod and Spark plug

- Remove flame rod terminal and tighten sparkler lead.
- Remove flame rod and spark plug.

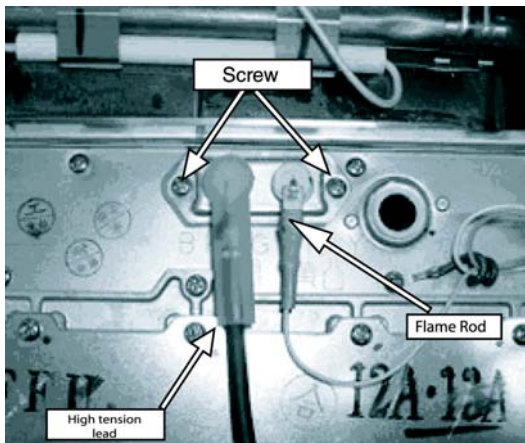

- Remove of High Tension lead

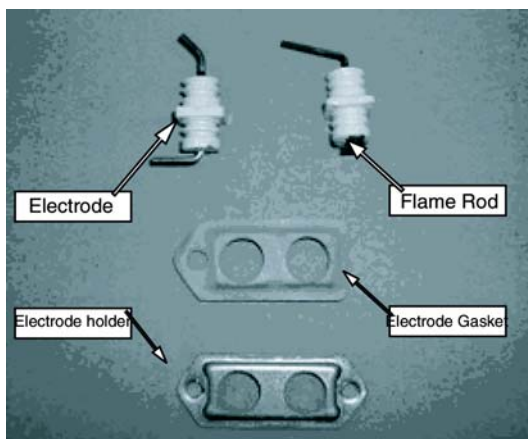

10) Removal of Outgoing Water Thermistor

- Remove thermistor fixing screw.
- Remove 2 pin connection outgoing water thermistor

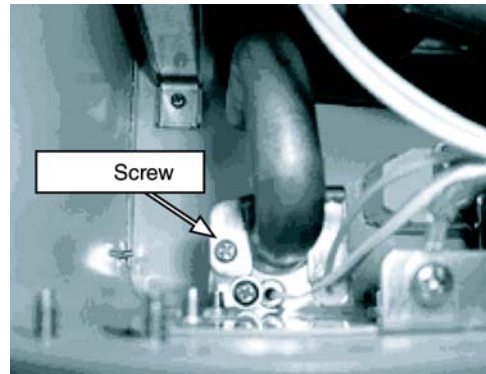

Heat Exchanger Thermistor



11) Removal of Heat Exchanger Thermistor REU-V2632WC (HD200E) ONLY

- Remove thermistor holder
- Remove 2 pin connector

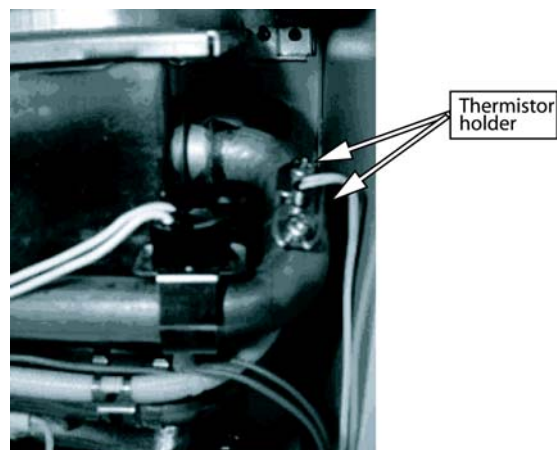

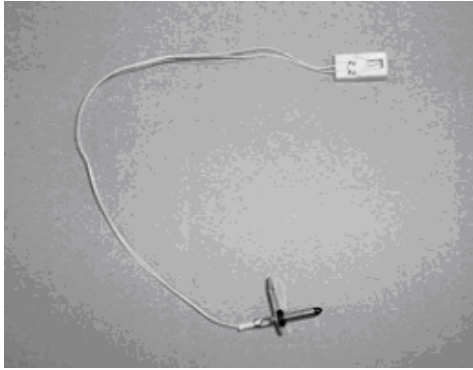

12) Removal of Bypass Servo - REU-V2632WC - (HD200E) ONLY

- a. Remove fan motor (Refer to point 16)
- b. Remove 3 pin connector
- c. Remove 2 pin connector
- d. Remove 6 pin connector and 5 pin connector
- e. Remove bracket for water connection tube.

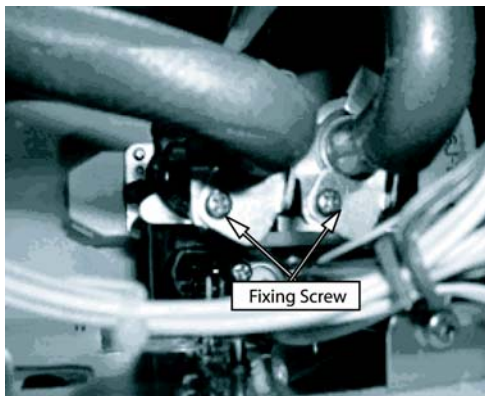

f. Removal of inlet water connection

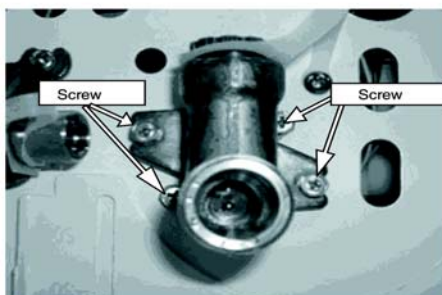

- g. Remove bypass servo and water flow servo
- h. Remove fitting screws of bypass servo

i. Flow sensor and water flow servo

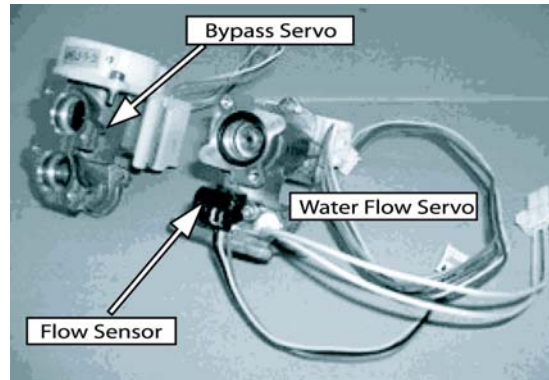

13) Removal of Anti Frost Switch

- a. Remove 2 pin connection for anti frost switch
- b. Remove Anti Frost switch

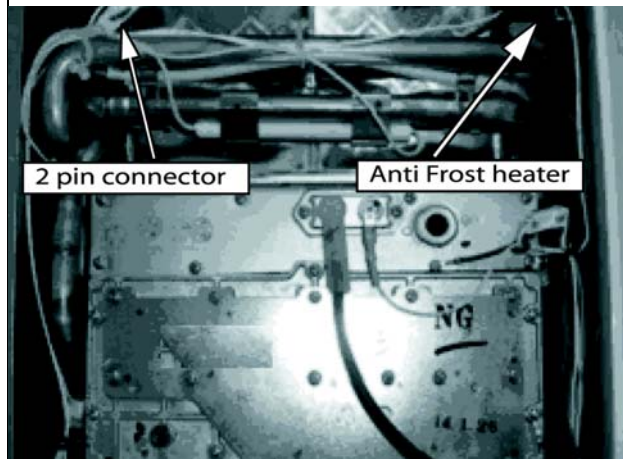

c. Anti Frost switch



14) Removal of Anti Frost heater

- a. Remove 2 pin connection of Anti Frost heater
- b. Remove bracket on hot water connection.
- c. Remove Anti Frost heater.

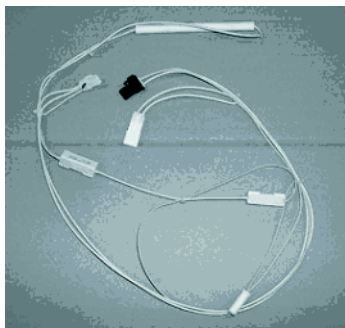
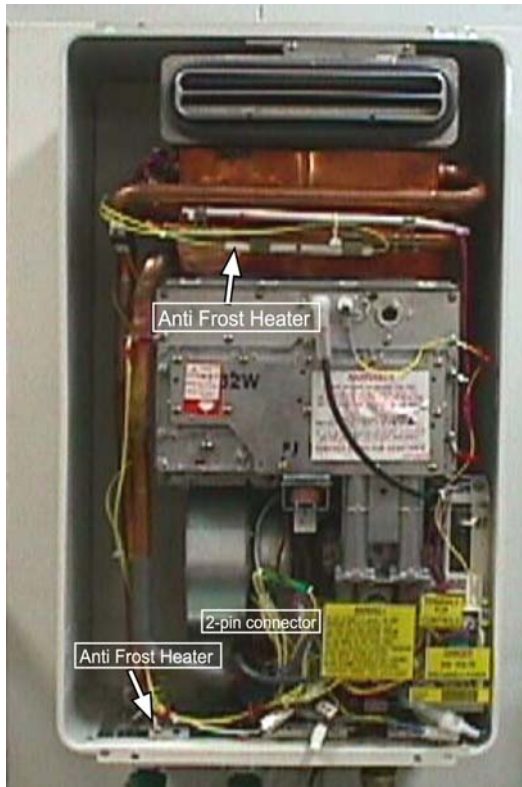

15) Removal of the Fan Motor

- a. Remove 4 pin connector to fan motor.
- b. Remove 2 pin connector of solenoid valve.

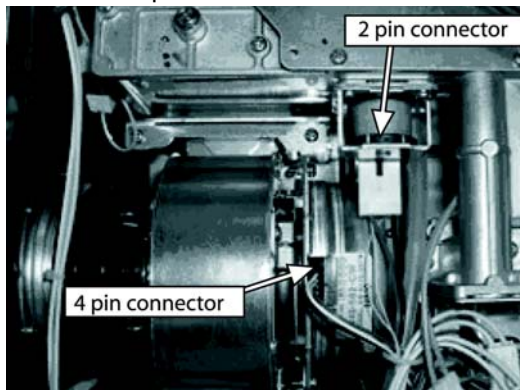

- c. Remove fan motor screws (x 2)

- d. Remove fan motor assembly by sliding forward

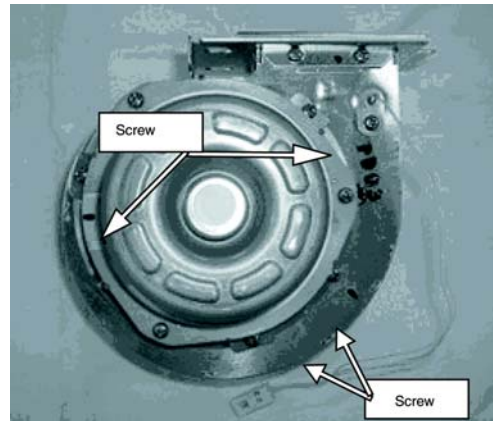

- e. Remove fan motor from housing via. 3 screws

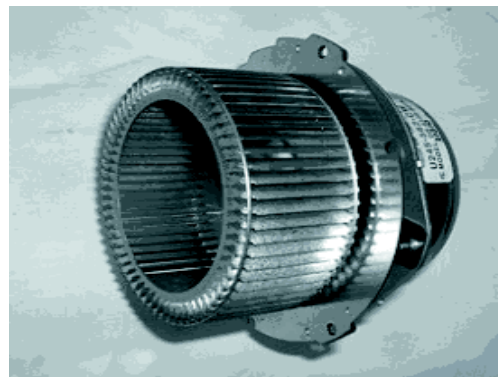

16) Removal of Heat Exchanger

- a. Remove PCB
- b. Remove fan motor
- c. Remove 2 pin connector of thermal fuse
- d. Remove flame rod terminal of high tension cord
- e. Remove anti frost heater switch
- f. Remove 2 pin connector
- g. Remove 3 pin connector
- h. Remove fixing screws of the heat exchanger unit
- i. Remove heat exchanger screws

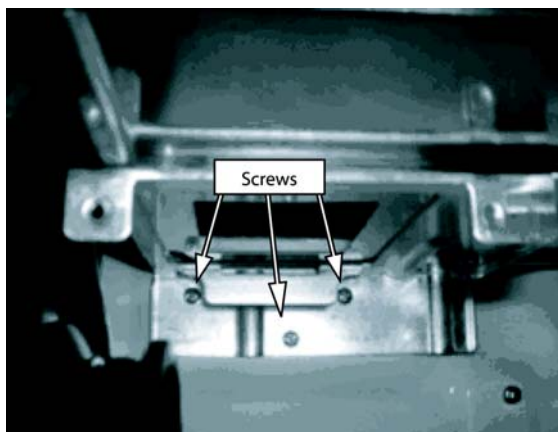
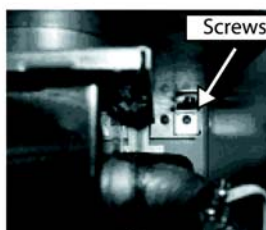
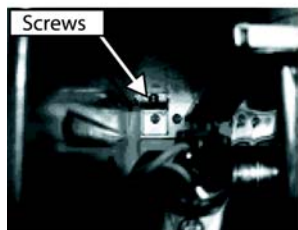

j. Remove Bypass tube - REU-V2632WC (HD200E) ONLY

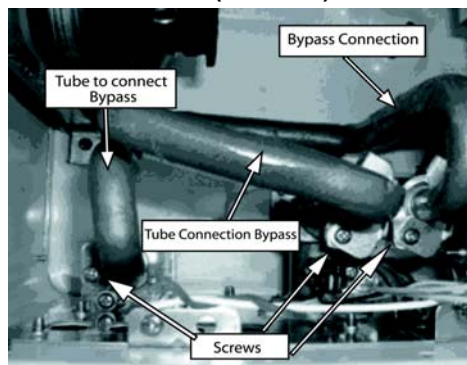

k. Pull out heat exchanger screws REU-V2632WC - (HD200E) - Heat Exchanger shown

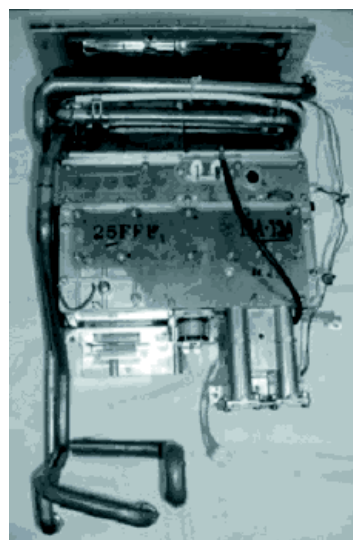

- l. Remove manifold and burner unit.
- m. Remove thermal fuse, over heat switch, sparker, hex thermister and back pressure joint.

REU-V2632WC - (HD200E) - Heat Exchanger shown



17) Removal of Thermal Fuse

- a. Remove heat exchanger.
- b. Remove Thermal Fuse.

After removal of thermal fuse fitting procedure is as follows:

Heat Exchanger Front

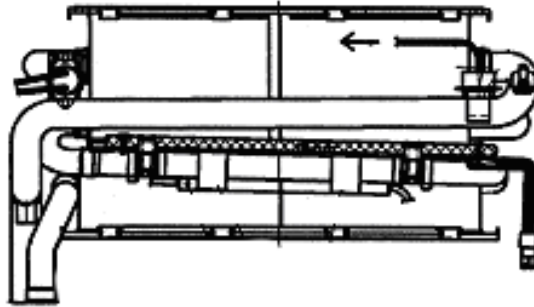

Heat Exchanger Right

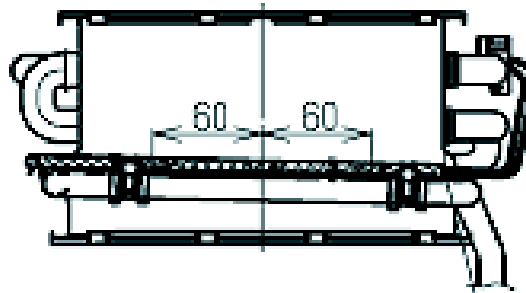

Heat Exchanger Left

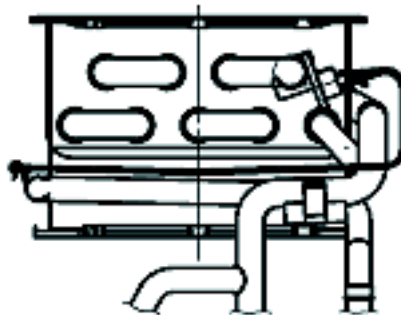

Heat Exchanger Right

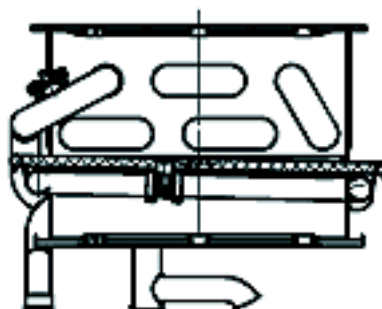

20. Exploded Diagram

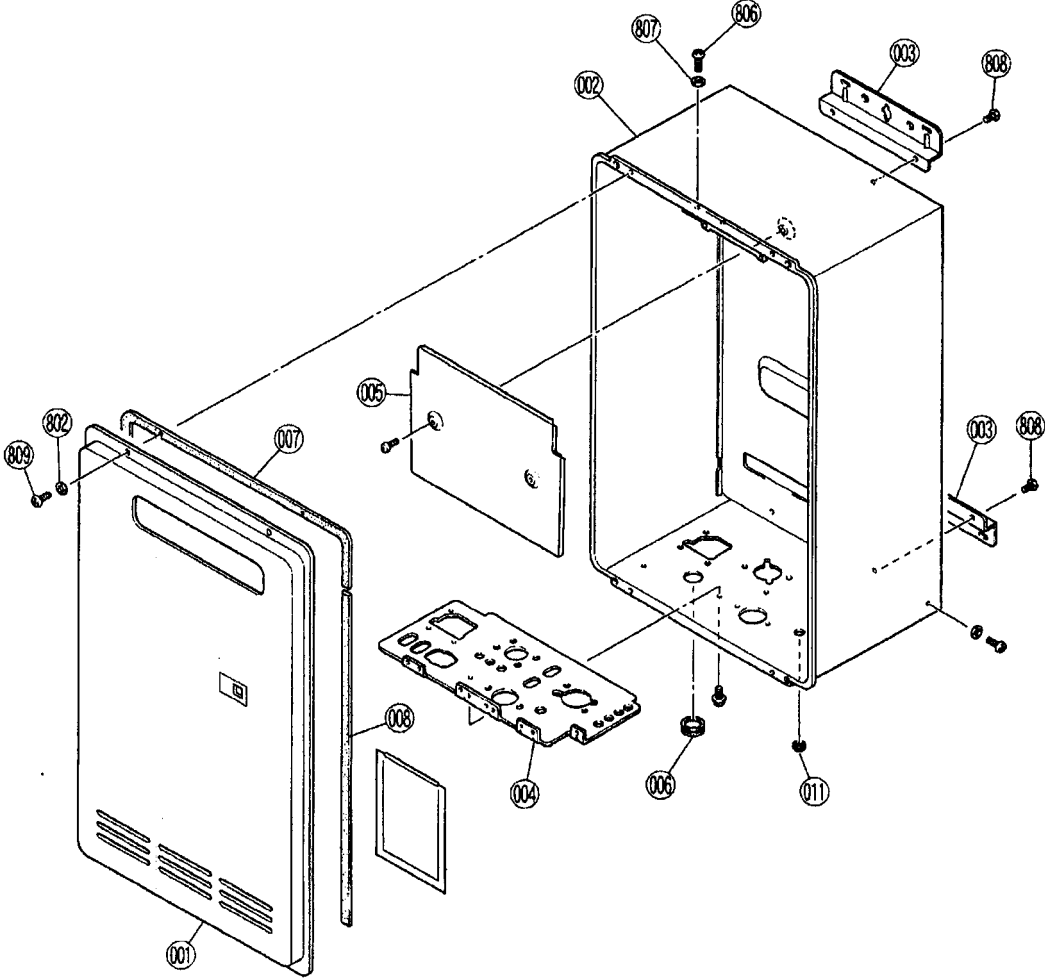

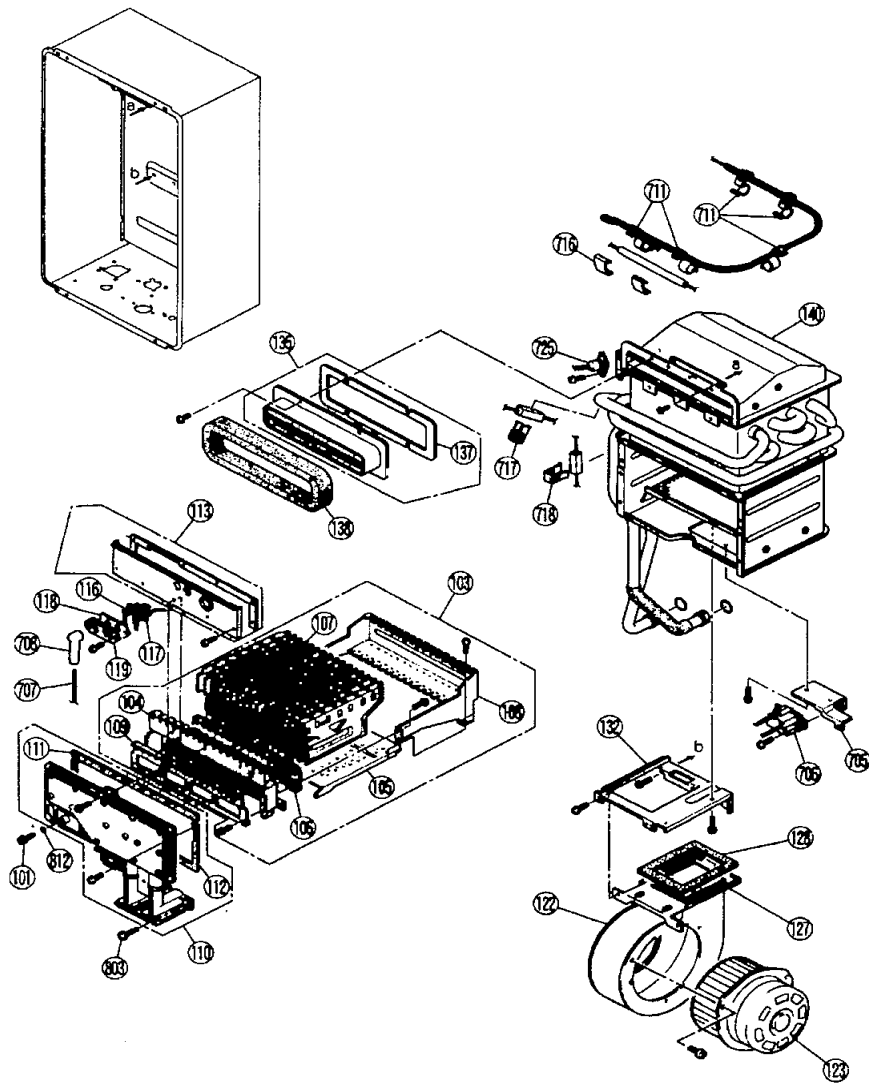

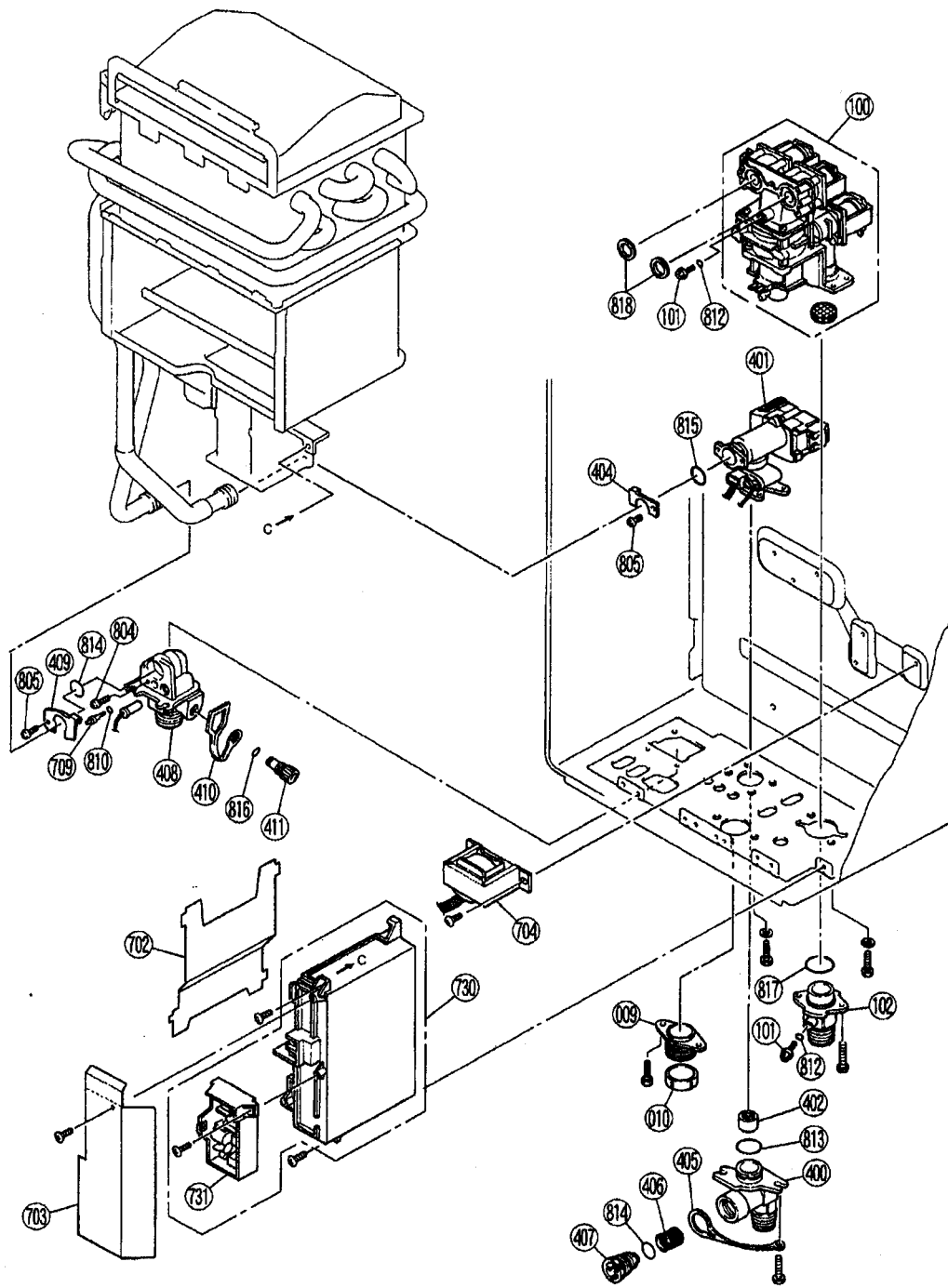

REU-V2632WC

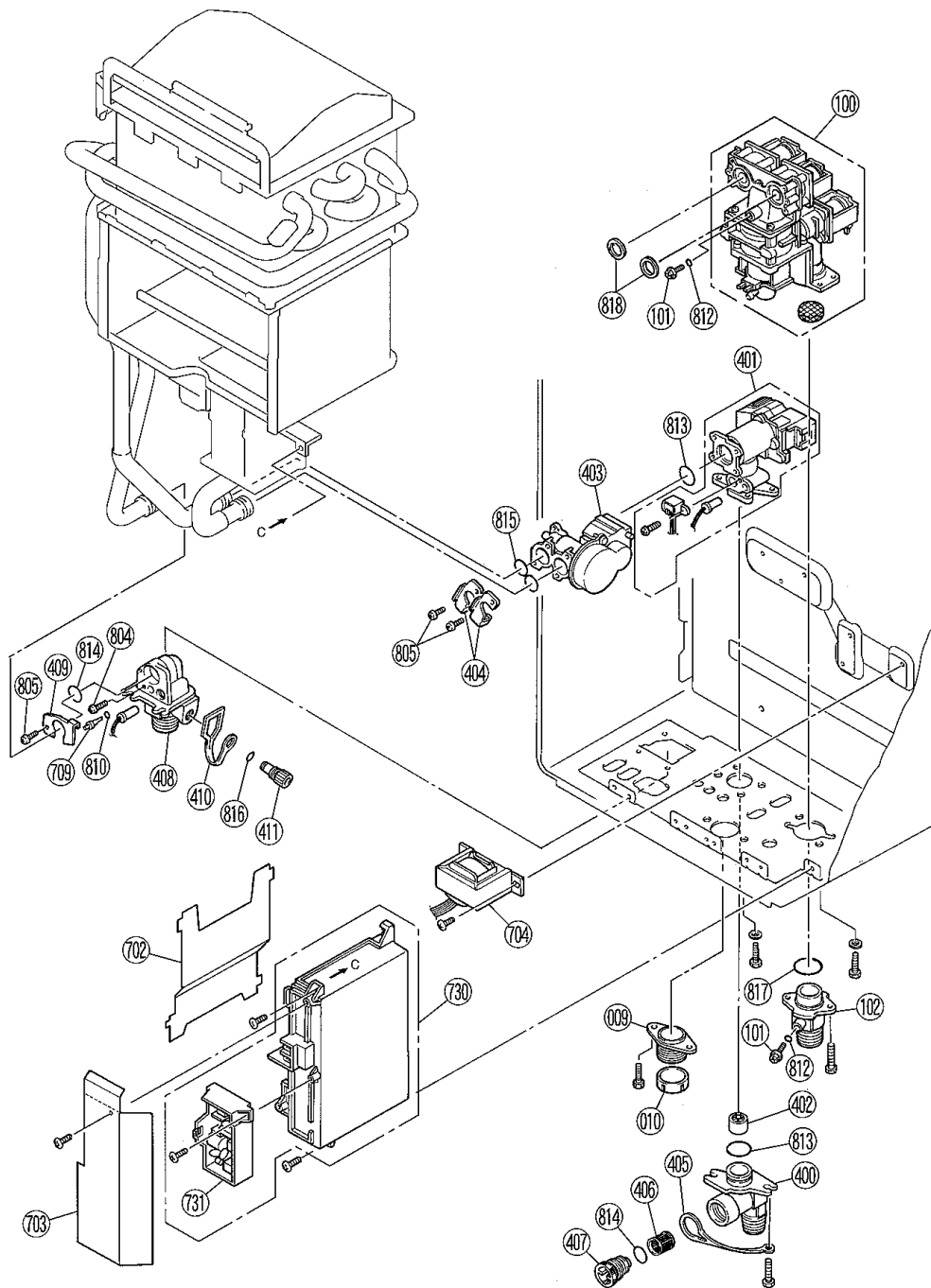

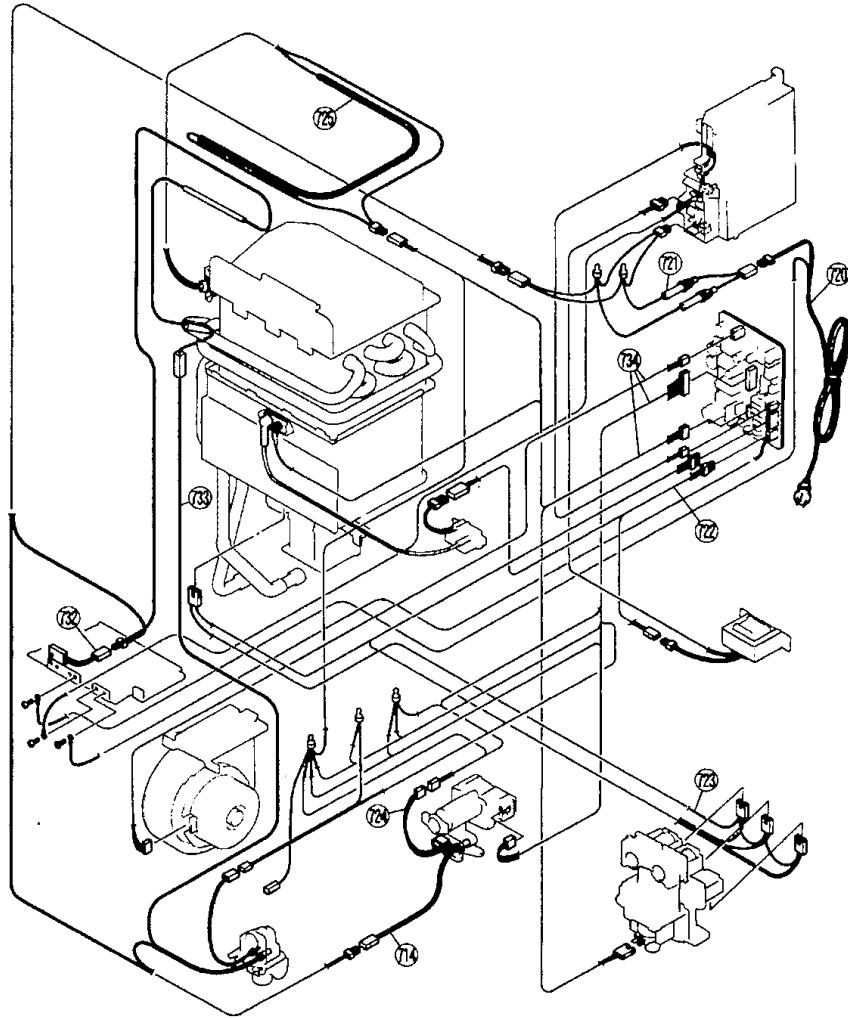

21. Parts List

“REU-V2626W” on page 57

“REU-V2632WC” on page 60

REU-V2626W

Effective Date: 30/08/2006

Supersedes: Jan. 2004

No.	PART NAME	RJ DRAWING No.	11 DIGIT CODE	RA PART No.	QTY
001	PANEL, Front	U245-1110-A	019-1806000	92092196	1
002	BODY Assy, Main	U245-1100	014-371-000	92092204	1
003	BRACKET, Mounting	BU195-121	106-329-000	92071323	2
004	PANEL, Connect Reinf.	U245-120	044-064-000		1
005	SHIELD, Heat Insul.	U245-107	030-915-000		1
006	GROMMET	CF79-41020-C	194-025-000		1
007	SEALING, Front Panel	BU195-167	580-453-000	92086909	1
008	SEALING, Body Side	AU115-163	510-990-000	92063361	2
009	ENTRY, Cable	BU56-602-N	106-104-000	92073352	1
010	GASKET, Cable Seal	AU169-126	580-306-000		1
011	GASKET	AU105-113	510-893-000		1
100	GAS CONTROL Assy	C36E-43-S	120-156-000	92092063	1
101	SCREW, T.P. Sealing	C10D-5	501-275-000	90195157	1
102	CONNECTION, Gas 3/4	CU195-211	106-290-000	92081587	1
103	BURNER, Unit Assy	H73-110	000-059-000	92092212	1
104	BURNER CASE, Fr Panel	CH51-209	098-902-000		1
105	BURNER CASE, Btm Plate	H73-112	005-137-000		1
106	GASKET, Bnr Case Fr	BH51-218	580-440-000		1
107	BURNER, Low NOx Bunsen Assy	B3A7-1	157-090-000		16
108	BURNER CASE, Back Plate	CH51-211	098-904-000		1
109	DAMPER	H73-115	140-597-000		1
110	MANIFOLD, Assy (LP)	U245-200-A	101-559-AU0	92092089	1
110	MANIFOLD, Assy (NG)	U245-200-C	101-579-AU0	92092550	1
111	SEALING, Combust.	AU155-207-2	580-547-000		1
112	SEALING, Lwr Comb.Cmbr	H73-214	580-569-000		1
113	FRONT PLATE, Comb. Cmbr Assy	U245-260	019-1337000		1
116	ELECTRODE	H73-120	202-156-000	92086974	1
117	ELECTRODE, Flame Rod	AH41-216	230-047-000	92086982	1
118	GASKET, Electrode	AH66-398	580-507-000	92086990	1
119	HOLDER, Electrode	AH66-393	580-505-000	92087006	1
122	FAN CASING, Assy		035-867-000		1
123	FAN MOTOR, Assy	H89-261	222-480-000	92092220	1
127	CONNECTION, Fan	BH29-606	106-320-000	92098870	1
128	PACKING, Fan Connect	AU183-562	580-338-000	92098888	1
132	BRACKET, Comb Cmbr	U245-255	538-512-000		1
135	FLUE TERMINAL, Assy	U245-1130	055-760-000	92092634	1
136	EXHAUST FLUE		055-760-000	92092634	1

REU-V2626W

Effective Date: 30/08/2006

Supersedes: Jan. 2004

No.	PART NAME	RJ DRAWING No.	11 DIGIT CODE	RA PART No.	QTY
137	GASKET, Flue Terminal	U245-1122	580-0023000		1
138	PACKING, Flue Term.	AH24-653-6	580-835-000		1
140	HEAT EXCHANGER, Assy	U245-340	314-525-000	92092238	1
400	CONNECTION, 3/4 Water	H73-501	333-301-000	92089044	1
401	SENSOR, Water Flow	M8E-4-8	301-096-000	92092246	1
402	RECTIFIER	M8D1-15	330-107-000		1
404	BRACKET	AH195-321	512-507-000		1
405	STRAP, Plug	H73-512	553-087-000		1
406	FILTER, Inlet Water	H73-511	017-268-000	92083773	1
407	FILTER, Plug	H73-510	196-031-000		1
408	3/4 WATER OUTLET	U245-865-1	333-386-000	92093806	1
409	BRACKET, Holder	AU162-1876	538-515-000		1
410	STRAP, Hot Water Outlet	AU129-526	553-043-000		1
411	VALVE, Assy Drain	BU129-520-C	337-048-000	92081751	1
702	PCB Assy Cover	BU195-507	098-442-000		1
703	PCB, Assy Cover Front	BU168-707	098-441-000		1
704	TRANSFORMER, Assy	ET-282	224-326-000	92092154	1
705	MOUNTING PLATE, PCB Case	U245-257	537-0060000		1
706	SPARKER	EI-189	261-153-000	92092162	1
707	LEAD, High Tension	BH38-710-240	203-828-000	92092253	1
708	SLEEVE, Electrode	AU206-218	518-035-000	92087030	1
709	THERMISTOR	BH45-650	233-108-000	92073675	1
710	BRACKET, Flame Rod	CP-90172	508-836-000	92086388	1
711	CLIP, Thermal Fuse	U217-676	537-505-000		5
714	HEATER, Water Flow	U245-776	235-309-000	92092261	1
716	MOUNTING BRACKET, Heater	CF29-742	538-493-000	92093301	2
717	CLIP, Heater A	AU111-653	537-155-000		1
718	CLIP, Heater B	AU100-721	537-174-000	92076123	1
720	ELECTRIC CORD	CP-90491T	206-226-000	92089051	1
721	HARNESS, Therm. Fuse	BU195-1630	290-0030000	92081900	1
722	HARNESS, 100V	U245-601	290-0389000		1
723	HARNESS, Solenoid Valve	U245-602	290-0390000		1
725	FUSE, Thermal Assy	U245-885	232-153-000	92092188	1
726	MR SENSOR, Assy	M8D1-10-4	243-072-000	92092279	1
730	PCB Assy	U245-1700	210-642-000	92092287	1
731	SUB BOARD, Assy	BU195-1643-2	210-565-000	92092147	1
732	SWITCH, Low Temp. Sensor	H73-750	234-444-000	92097187	1

REU-V2626W

Effective Date: 30/08/2006

Supercedes: Jan. 2004

No.	PART NAME	RJ DRAWING No.	11 DIGIT CODE	RA PART No.	QTY
733	HEATER, A/Frost Assy	U245-1620	235-310-000		1
734	HARNESS-3, Sensor SW	U245-605	290-0537000		1
	DECAL PANEL, Front		602-0010000	92092725	1
802	WASHER	AU33-184	503-022-010		3
803	SCREW	CP-21478-412	501-400-000		3
804	SCREW, Thermistor	U217-449	501-295-000		1
805	SCREW, Small Pan	ZAA0408UK	501-262-000		2
806	SCREW	ZBD0508UK	501-802-000		2
807	WASHER	AU48-174	503-026-000		2
808	SCREW	ZBA0510UK	501-397-010		4
809	SCREW	ZAD0408UK	501-399-010		3
809	SCREW	ZHDC408UK	501-409-000		1
810	O-RING	M10B-2-4	520-209-010	92062249	1
812	O-RING	M10B-13-4	520-300-010	90195165	3
813	O-RING	M10B-2-18	520-049-010	92071182	1
814	O-RING	M10B-2-16	520-048-010	92062199	2
815	O-RING	M10B-2-14	520-193-010	92062207	1
816	O-RING	M10B-2-7	520-281-010	92062348	1
817	O-RING	M10B-1-24	520-043-010	92072859	1
818	WASHER	C36E1-6	580-180-000		2
888	CUSTOMER INSTRUCTION	U245-795	623-782-000		1
888	CUSTOMER INSTRUCTION	U245-796	623-783-800		
889	INSTALLATION INSTRUCTION	U245-1650	K23-820-600		1

REU-V2632WC

Effective Date: 30/08/2006

Supersedes: Jan. 2004

No.	PART NAME	RJ PART CODE	11 DIGIT CODE	RA PART NUMBER	QTY
001	PANEL, Front	U245-1110-3	019-1809000	92092410	1
002	OUTER CASE	U245-1100-3	014-381-000	92095884	1
003	BRACKET, Wall Mount.	BU195-121	106-329-000	92071323	1
004	PANEL, Conn. Reinf.	U245-120	044-064-000		1
005	SHIELD, Heat Insul.	U245-107	030-915-000		1
006	GROMMET	CF79-41020-C	194-140-000		1
007	SEALING, Front Panel	BU195-167	580-453-000	92086909	1
008	SEALING, Body Side	AU115-163	510-990-000	92063361	2
009	SKIRT, Cable	BU56-602-N	106-104-000	92073352	1
010	GASKET, Cable Seal	AU169-126	580-306-000		1
011	PACKING	AU105-113	510-893-000		1
100	GAS CONTROL, Assy	C36E-43-S	120-156-000	92092063	1
101	SCREW, T.P. Seal.	C10D-5	501-275-000	90195157	3
102	CONNECTION, Gas 3/4	CU195-211	106-290-000	92081587	1
103	BURNER, Unit Assy	H73-110	000-059-000	92092212	1
104	BURNER CASE, Fr Panel	CH51-209	098-902-000		1
105	BURNER CASE, Btm Plate	H73-112	005-137-000		1
106	GASKET, Bnr Case Fr	BH51-218	580-440-000		1
107	BURNER, Low NOx Bunsen Assy	B3A7-1	157-090-000		16
108	BURNER CASE, Back Plate	CH51-211	098-904-000		1
109	DAMPER	H73-115	140-597-000		1
110	MANIFOLD, Assy (LP)	U245-200-A	101-559-AU0	92092089	1
110	MANIFOLD, Assy (NG)	U245-200-C	101-633-AU0	92094309	1
111	SEALING, Combust.	AU155-207-2	580-547-000		1
112	SEALING, Lwr Comb.Cmbr	H73-214	580-569-000		1
113	FRONT PLATE, Comb. Cmbr Assy	U245-261	019-1337000		1
116	ELECTRODE	H73-120	202-156-000	92086974	1
117	FLAME ROD	AH41-216	230-047-000	92086982	1
118	GASKET, Electrode	AH66-398	580-507-000	92086990	1
119	HOLDER, Electrode	AH66-393	580-505-000	92087006	1
122	FAN CASING, Assy	CH51-615	035-867-000		1
123	FAN MOTOR, Assy	H89-261	222-480-000	92092220	1
127	PACKING, Fan Connect	BH29-606	106-320-000	92098870	1
128	PACKING, Fan Connect	AU183-562	580-338-000	92098888	1
132	BRACKET, Comb Cmbr	U245-255	538-512-000		1
136	FLUE EXHAUST	U245-1130	055-760-000	92092634	1
137	GASKET, Flue Terminal	U245-1122	580-0023000		1
138	PACKING, Flue Term.	AH24-653-6	580-835-000		1

REU-V2632WC

Effective Date: 30/08/2006

Supersedes: Jan. 2004

No.	PART NAME	RJ PART CODE	11 DIGIT CODE	RA PART NUMBER	QTY
140	HEAT EXCHANGER, Assy	U245-1310-C-S	314-524-000	92093550	1
400	CONNECTION, 3/4 Inlet Water	H73-501	333-301-000	92089044	1
401	SERVO, Water Flow Sensor	M8E-6-6 / M8E-6-7	301-095-000	92097815	1
402	RECTIFIER	M8D1-15	330-107-000		1
403	SERVO, By-Pass Assy	M6J-1-3	301-084-000	92092121	1
404	BRACKET, Stop	AH69-310	512-401-000		2
405	PLUG, Band	H73-512	553-087-000		1
406	FILTER, Inlet Water	H73-511	017-268-000	92083773	1
407	FILTER, Plug	H73-510	196-031-000		1
408	3/4 Outlet Water	U245-865-1	333-386-000	92093806	1
409	BRACKET, Stop	AU162-1876	538-515-000		1
410	VALVE, Assy Drain	AU129-526	553-043-000		1
411	VALVE, Pressure Relief	BU129-520-C	337-048-000	92081751	1
702	PCB, Cover-Side	BU195-507	098-442-000		1
703	PCB Cover-Front	BU168-707	098-441-000		1
704	TRANSFORMER, Assy	ET-282	224-326-000	92092154	1
705	BRACKET, PCB	U245-257	537-0060000		1
706	SPARKER	EI-189	261-153-000	92092162	1
707	LEAD, High Tension	BH38-710-240	203-828-000	92092253	1
708	ELECTRODE, Sleeve	AU206-218	518-035-000	92087030	1
709	THERMISTOR	BH45-650	233-108-000	92073675	2
710	BRACKET, Flame Rod	CP-90172	508-836-000	92086388	1
711	CLIP, Thermal Fuse	U217-676	537-505-000		5
714	HEATER, Water Flow	U245-776	235-309-000	92092261	1
716	HEATER	CF29-742	538-493-000	92093301	2
717	HEATER A	AU111-653	537-0059000	92093319	1
718	HEATER B	AU100-721	537-174-000	92076123	1
720	ELECTRIC CORD	CP-90491T	206-226-000	92089051	1
721	HARNESS, Therm. Fuse	BU195-1630	290-0030000	92081900	1
722	HARNESS, 100V	U245-601	290-0389000		1
723	HARNESS, Solenoid Valve	U245-602	290-0390000		1
725	FUSE, Thermal Assy	U245-885	232-153-000	92092188	1
726	MR SENSOR, Assy	M8D1-10-4	243-072-000	92092279	1
730	PCB Assy	U245-1600-B	210-642-000	92093668	1
731	SUB BOARD, Assy	BU195-1643-2	210-565-000	92092147	1
732	SWITCH, Low Temp. Sensor	H73-750	234-444-000	92097187	1
733	HEATER, A/Frost Assy	U245-1620	235-310-000		1
734	HARNESS-3, Sensor SW	U245-603-3	290-0572000		1

REU-V2632WC

Effective Date: 30/08/2006

Supercedes: Jan. 2004

No.	PART NAME	RJ PART CODE	11 DIGIT CODE	RA PART NUMBER	QTY
802	WASHER	AU33-184	503-022-010		3
803	SCREW	CP-21478-412	501-400-000		3
804	SCREW, Thermistor	U217-449	501-295-000		1
805	Screw Small Pan	ZAA0408UK	501-262-000		3
806	SCREW	ZBD0508UK	501-802-000		2
807	SCREW	AU48-174	503-026-000		2
808	SCREW	ZBA0510UK	501-397-000		4
809	SCREW	ZAD0408UK	501-542-010		3
809	O-RING	ZHDC0408TK	501-850-000		1
810	O-RING	M10B-2-4	520-209-010	92062249	2
812	O-RING	M10B-13-4	520-300-010	90195165	3
813	O-RING	M10B-2-18	520-049-010	92071182	2
814	O-RING	M10B-2-16	520-048-010	92062199	2
815	O-RING	M10B-2-14	520-193-010	92062207	2
816	O-RING	M10B-2-7	520-281-010	92062348	1
817	O-RING	M10B-1-24	520-043-010	92072859	1
818	WASHER	C36E1-6	580-180-000		2
888	CUSTOMER INSTRUCTION	U245-795	623-782-000		1
889	INSTALLATION INSTRUCTION	U245-1650	K23-820-600		1

SERVICE CONTACT POINTS

Rinnai
AUSTRALIA PTY. LTD

ACN 005 138 769 ABN 74 005 138 769

Internet: www.rinnai.com.au
E-mail: enquiry@rinnai.com.au

Head Office, Australia

10-11 Walker Street, Braeside, VIC 3195
Tel: (03) 9271 6625
Fax: (03) 9271 6622

Help Line: Sales & Service

Tel: 1300 555 545
Fax: 1300 555 655

Hot Water Service Line

Tel: 1800 000 340

Help Line: Spare Parts & Technical Info

Tel: 1300 366 388
Fax: 1300 300 141

Rinnai
NEW ZEALAND LTD.

Internet: www.rinnai.co.nz
E-mail: sales@rinnai.co.nz

Head Office, New Zealand

691 Mt. Albert Road, Royal Oak,
Auckland
P O Box 24-068

Tel: (09) 625 4285
Fax: (09) 624 3018

24 hr Service
Tel: 0800 746624 (0800 Rinnai)