

SERVICE MANUAL

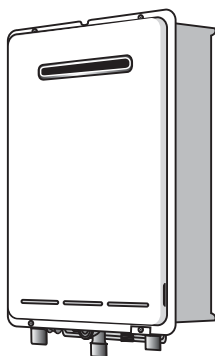

To Suit Models:

REU-V3237WG
REU-VM3237WC

Does NOT suit any other Models.



The Australian
Gas Association

All Rinnai products are certified by the Australian Gas Association as compliant to relevant Australian Standards.



Distributed and serviced in Australia under a Quality System certified as complying with ISO 9001 by SAI Global

Rinnai Australia Head Office is certified as complying with ISO 9001 by SAI Global.



Quality
Endorsed
Company

ISO 9001 Reg 415

Rinnai New Zealand has been certified to ISO 9001 Quality Assurance by Telarc.

Certified
Product



WaterMark

AS3498 Lic W208
SAI Global

All Rinnai products are Certified to WaterMark by SAI Global. WaterMark certification is awarded to products and fittings complying with safety and water contamination standards.

© Copyright Rinnai Australia Pty Ltd ABN 74 005 138 769
All rights reserved
Produced by Engineering & Technical Group

No portion or part of this manual may be copied without prior permission from Rinnai Australia.

Rinnai Australia reserves the right to make modifications and change specifications without notice.



W A R N I N G



Failure to comply with these instructions may result in serious personal injury or damage to the appliance.



- All wiring inside this appliance may be at 240 Volts potential.
- All service work must be carried out by an authorised person.

This manual has been published by Rinnai Australia Engineering & Technical Group.

We welcome users of this manual to provide feedback and suggestions for improvement purposes.

Glossary of Terms and Symbols

dB(A)	-	sound pressure level in decibels, “A” range
DC	-	direct current
AC	-	alternating current
WFCD	-	water flow control device
FB	-	feedback information
FF	-	feedforward information
Hz	-	Hertz
IC	-	integrated circuit
kcal/h	-	kilocalorie per hour
kPa	-	kilopascals
LED	-	light emitting diode
L/min	-	Litres per minute
mA	-	milliamps
MJ/h	-	megajoule per hour
mm	-	millimetres
mmH ₂ O	-	millimetres of water (gauge pressure)
OHS	-	overheat switch
PCB	-	printed circuit board
CPU	-	central processing unit
POT	-	potentiometer
rpm	-	revolutions per minute
SV	-	solenoid valve
∅	-	diameter
Δ °C	-	temperature rise above ambient
POV	-	modulating valve
TE	-	thermal efficiency
TH	-	thermistor
T _{IN}	-	temperature of incoming water
T _{OUT}	-	temperature of outgoing water

Table of Contents

Glossary of Terms and Symbols	iv
1. Specifications	1
2. Water Flow Rates and Pressures	3
3. Dimensions	4
4. Water Controllers	5
5. Smartstart	7
6. Cutaway Diagram	8
7. Operational Flow Chart	9
8. Operation Principles	11
9. Main Components	12
10. Time Charts	13
11. Wiring Diagram	14
12. Diagnostics Points	15
13. Dip Switch Settings	16
14. Fault Finding	17
15. Component and Circuit Checks	19
16. Gas Pressure Setting Procedure	25
17. Gas Conversion Procedure	25
18. Maintenance Monitor / Error History	26
19. Dismantling for Service	29
20. Parts List	35
21. Exploded Diagram	38
SERVICE CONTACT POINTS	42

1. Specifications

Rinnai model number	REU-V3237WG REU-VM3237WC
Type of appliance	Temperature controlled continuous flow gas hot water system
Exhaust system	Fan Forced Flue
Installation	External
Dimensions	Width - 470 mm Height - 600 mm Depth - 244 mm
Weight	29 kilograms
Gas consumption (Min. / Max.)	Natural gas : Approx. 21 ~ 250 MJ/h Propane gas : Approx. 21 ~ 250 MJ/h
Output (kW) (Maximum)	55.5 kW
Connections 1620WG / WB	Gas connection - R3/4 (20A) Cold water connection - R 3/4 (20A) Hot water connection - R 3/4 (20A)
Ignition system	Direct electronic ignition
Electrical consumption	Normal - 65 W Standby - 2 W (with 1 water control) Anti-frost protection - 100 W
Hot water capacity (Raised 25°C)	2.4 to 32 L/min
Temperature range (with controller)	Kitchen water controller : 37 ~ 55°C Bathroom water controller: 37 ~ 50°C
Delivery temperatures	40°C, 42°C, 50°C, 55°C, 65°C, 75, 85, 95°C (set by combination of dip switches on PCB) NOTE: 95°C appliance must be factory converted by Rinnai.
Water flow control	Water flow sensor, Electronic water flow control device
Maximum hot water capacity, raised @ 25°C	32 L/min
Water pressure required to achieve maximum hot water capacity	140 kPa
Maximum water flow	37 L/min
Water pressure required to achieve maximum hot water flow	190 kPa
Minimum water flow	2.4 L/min
Power supply	Appliance - AC 240 Volts 50 Hz Water controller - DC 12 Volts
Water controllers (optional)	A maximum of 4 water controllers can be fitted. Any combination of deluxe, universal and wireless controllers can be used with the following limitations: Only ONE master controller can be installed. This can be a MC-100V, a MC-91Q (when programmed as a mater controller) or a MC-502RC/MC-503RC water controller. Up to TWO BC-100V water controllers can be installed. The FOURTH water controller in any installation MUST be a MC-502RC / MC-503RC or a MC-91Q.
Water Controller Cable	Cables are supplied with water controllers. Alternatively, two core sheathed (double insulated) flex with minimum cross sectional area of 0.5 m ² may be used. Maximum individual cable runs should not exceed 50 m.

Sensors and Safety Functions

- **Hot Water Delivery Thermistor:** Measures hot water temperature at the outlet valve (i.e. the ‘mixed’ temperature).
- **Heat Exchanger Thermistor:** Measures water temperature in the heat exchanger.
- **Flame Rod:** Monitors combustion characteristics inside the combustion chamber. If the flame fails, gas supply is stopped.
- **Overheat Switch:** Situated on the heat exchanger, gas supply is stopped when water temperature reaches 97°C for a number of seconds.
- **Fusible Link:** Situated on the heat exchanger, electrical power supply is stopped if the temperature exceeds 129°C.
- **Water Pressure Relief Valve:** Safeguards the water circuit against excessive inlet pressure. Opens at 2060 kPa, closes at 1470 kPa.
- **Electrical Fuse:** (3A glass fuse) prevents against power surges.
- **Surge Protector:** prevents against over-current.
- **Boil Dry Prevention:** If water flow sensor detects no flow, gas supply is stopped.
- **Combustion Fan Speed Sensor:** In case of combustion fan defect (no rotation of fan blades) gas supply is stopped.
- **Temperature Cutout:** If the delivered hot water temperature rises above the required delivery temperature for a number of seconds, the gas supply is stopped.

Combustion Specifications

Refer to dataplate on the appliance.

2. Water Flow Rates and Pressures

Water flow vs inlet pressure 3237

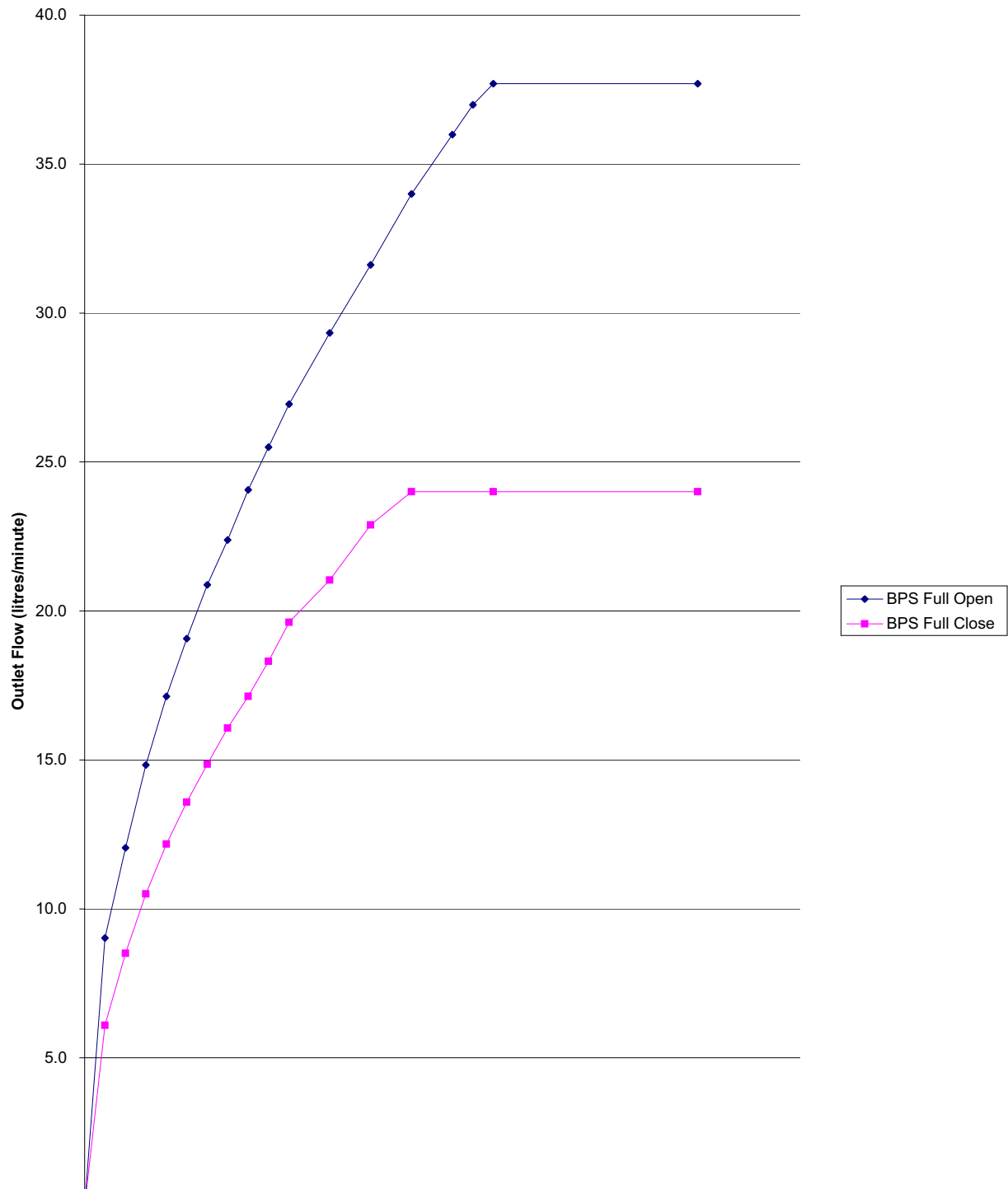

REU-VM3237W		BPS full close																
P(kPa)	0.0	10.0	20.0	30.0	40.0	50.0	60.0	70.0	80.0	90.0	100.0	120.0	140.0	160.0	200.0	300.0		
Q(L/min)	0.0	6.1	8.5	10.5	12.2	13.6	14.9	16.1	17.1	18.3	19.6	21.0	22.9	24.0	24.0	24.0		
REU-VM3237W		BPS full open																
P(kPa)	0.0	10.0	20.0	30.0	40.0	50.0	60.0	70.0	80.0	90.0	100.0	120.0	140.0	160.0	180.0	190.0	200.0	300.0
Q(L/min)	0.0	9.0	12.1	14.8	17.1	19.1	20.9	22.4	24.1	25.5	26.9	29.3	31.6	34.0	36.0	37.0	37.7	37.7

BPS = Heat Exchanger Bypass Servo

3. Dimensions

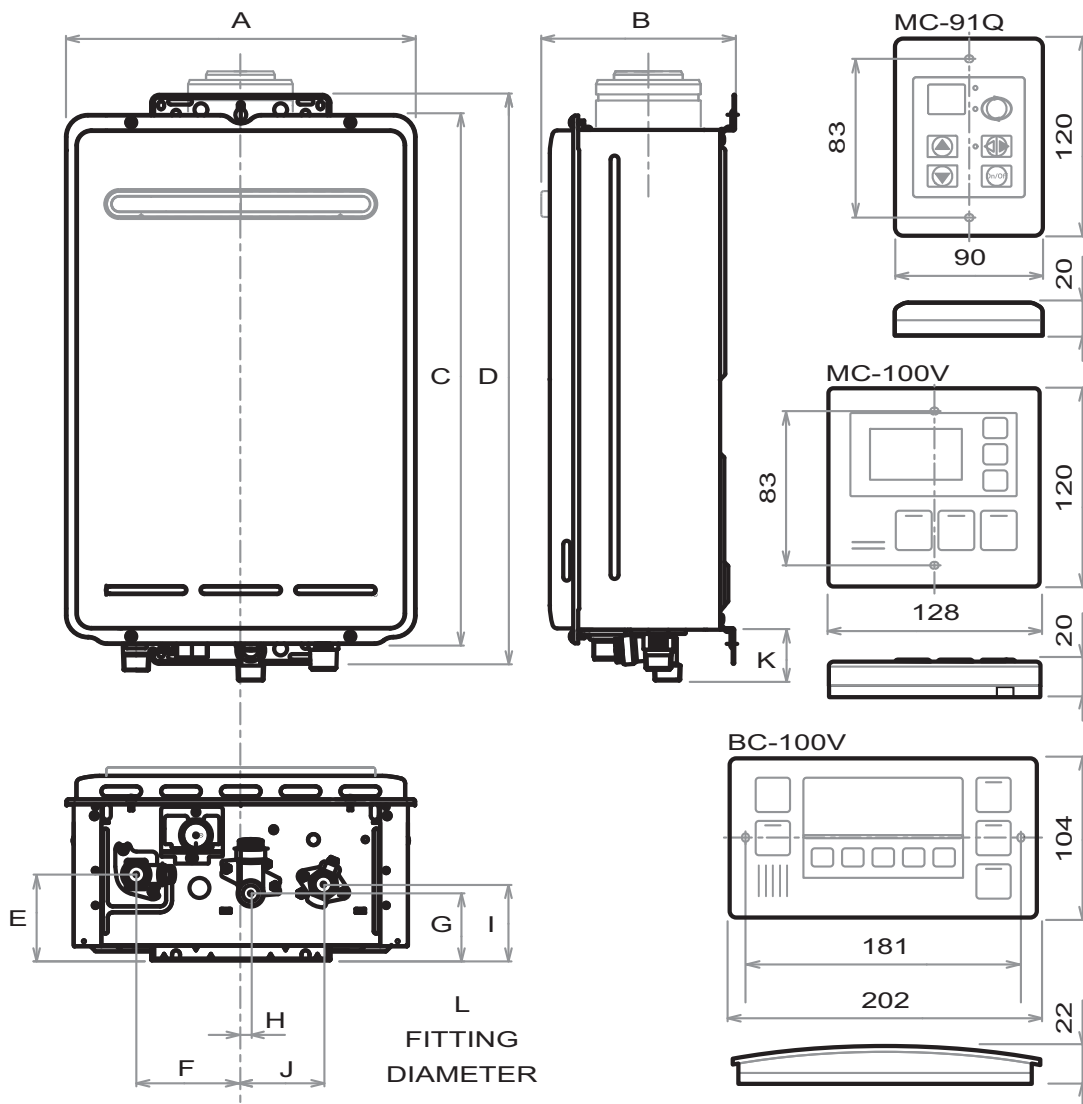

Dim'	Description	REU-V3237WG REU-VM3237WC
A	Width	470
B	Depth	244
C	Height - Unit	600
D	Height - Including Brackets	644
E	Hot Water outlet (from wall)	115
F	Hot Water outlet (from centre)	61
G	Cold Water inlet (from wall)	99
H	Cold Water inlet (from centre)	52
I	Gas Connection (from wall)	61
J	Gas Connection (from centre)	110
	Gas: Length (from base)	41
K	Cold: Length (from base)	51
	Hot: Length (from base)	42
	Gas: Fitting Diameter	20
L	Cold: Fitting Diameter	20
	Hot: Fitting Diameter	20

* Please note that this measurement is to the left of the centre line.

4. Water Controllers



All water controllers must be installed in accordance with the relevant operation/installation instructions supplied with the water heater or controllers.

Trouble shooting

Water Controller not showing display - (Wired Water Controllers)

- Check that the correct number and combination of controllers have been installed for the specific model Infinity. Refer to controller compatibility table below.
- Check water controller is turned ON.
- Check there is 12VDC power supply available to the controller from the Ezi-connect terminals.
- If there is 12VDC available from the Ezi Connect but no controller display, check wiring between Ezi-connect and controller is sound.
- If there is no power from the Ezi-connect terminals, but the hot water functions correctly, replace PCB.

Error Code 12 as soon as hot water tap is turned ON.

- Check 12VDC internal wiring to Ezi-connect terminal is not crushed or shortened.
- Rectify wiring and re-close Ezi-connect cover carefully.

Water Controller not showing display - (Wireless Water Controllers)

- Ensure transceiver module is mounted in the correct location, as per wireless controller installation instructions.
- Ensure 2 x AA batteries are in good working order and installed with the correct polarity within the wireless controller. (Battery polarity details on rear of wireless controller)
- Ensure distance between wireless controller and transceiver does not exceed 50 metres.
- Ensure channel has been allocated to each wireless water controller.
- Ensure wireless controller has been programmed to the transceiver correctly, as per wireless water controller installation instructions.

Water Controller Compatibility Table

Wireless Only Installation	A maximum of 4 wireless water controllers can be fitted with the following limitation: Only <u>ONE</u> MC-502RC can be set as the Master Controller.
Wired & Wireless Installations	A maximum of 4 water controllers can be fitted. Any combination of deluxe, universal and wireless controllers can be used with the following limitation: Only <u>ONE</u> master controller can be installed. This can be a MC-100V, a MC-91Q (when programmed as a master controller) or a MC-502RC water controller. Up to <u>TWO</u> BC-100V water controllers can be installed. The <u>FOURTH</u> water controllers in any installation <u>MUST BE</u> a MC-502RC or a MC91Q.

PROGRAMMING FOR THE 'UNIVERSAL' WATER CONTROLLER (MC-91Q)



1 Are there four water controllers connected?

IF NO: (You have three water controllers or fewer), go to Question 2.

IF YES: You will need to activate the fourth water controller as follows:

STEP 1: For the water controller in the KITCHEN ONLY, press and hold the 'Transfer' and 'On/Off' buttons simultaneously (see Fig. 5) until a 'beep' is heard (approximately 5 seconds).

STEP 2: Check that the display on ALL FOUR water controllers is lit and displaying a temperature when 'switched on'. If any ONE of the controller displays two dashes (see Fig. 6) repeat STEP 1.

This completes the activation procedure for the fourth controller, you may ignore Question 2.

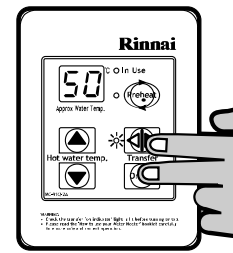

Fig. 5



Fig. 6



2 Is the water heater marked to state it delivers water not exceeding 50°C?

IF YES: No further action required.

IF NO: You will need to program the kitchen controller to enable selection of temperatures higher than 50°C.

STEP 1: For the controller in the KITCHEN ONLY, press and hold the 'Transfer' and 'On/Off' buttons simultaneously (Fig. 7) until a 'beep' is heard (approximately 5 seconds).

STEP 2: When the controller fitted in the KITCHEN is switched On, it should be possible to select temperatures higher than 50°C. If not, repeat STEP 1.

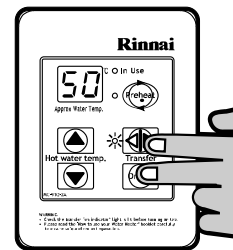

Fig. 7



If the water controller in the kitchen is replaced, repeat STEP 1 above for the replacement controller.

If the water controller in the kitchen is swapped with another controller (for example, the controller fitted in a bathroom), repeat STEP 1 for the controller moved from the kitchen to the bathroom. Then perform STEP 1 for the controller moved from bathroom to the kitchen.

5. Smartstart

At least one temperature controller model MC-91Q must be used in conjunction with the water heater and the Smartstart® system. Alternatively, if water controllers cannot be used a manual activation switch must be used. Water Controllers cannot be used with the 1620WS model.

The installation of the water heater and temperature controllers must be performed in accordance with the installation instructions supplied with the water heater.

The Smartstart® system is designed for domestic installations. However, it may be suitable for certain non domestic installations. See separate service manual for more information.

Principle of Operation (Fig.2)

The "Smartstart®" system heats the water in the pipework water connected between the water heater and the hot water outlets before any outlets are opened using the 'flow and return' pipework principle. This results in water savings and reduced waiting time for heated water delivery from the outlet when opened.

Traditional 'flow and return' systems usually keep the water in the pipework heated continuously. The Smartstart® system however, only heats the water before the outlet is opened. This results in significant energy savings because water is not heated unnecessarily whilst retaining the benefits of traditional flow and return systems.

A schematic of the Smartstart® system installed in conjunction with a Rinnai continuous flow water heater and temperature controller is shown in Fig.2 below.

If problems are experienced with Smartstart® operation refer to the Smartstart® Service Manual.

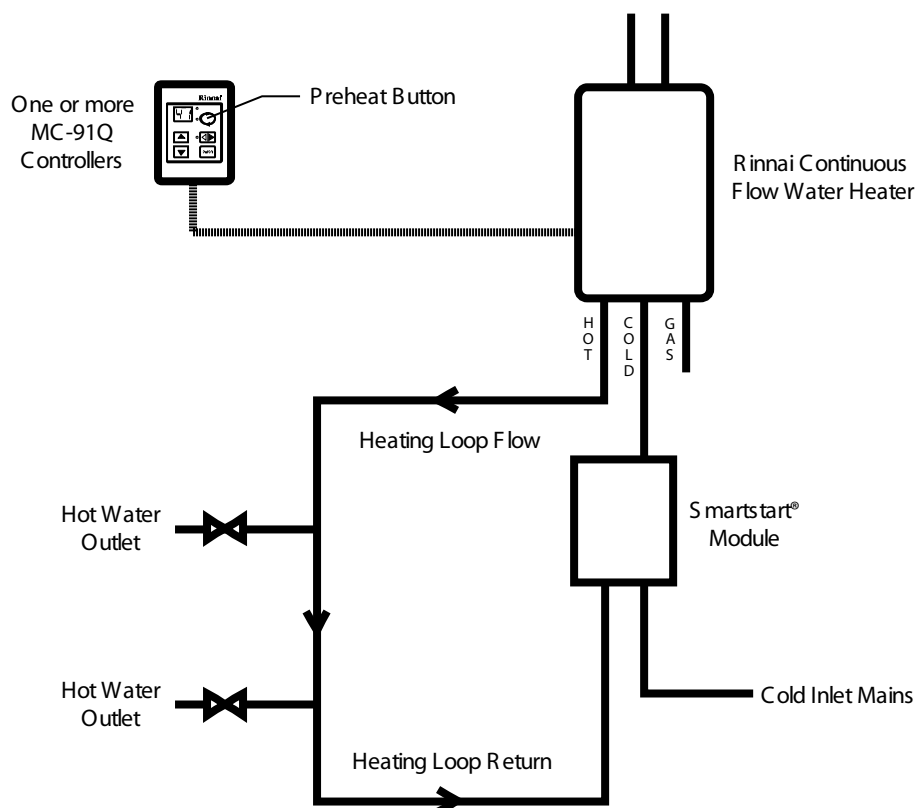
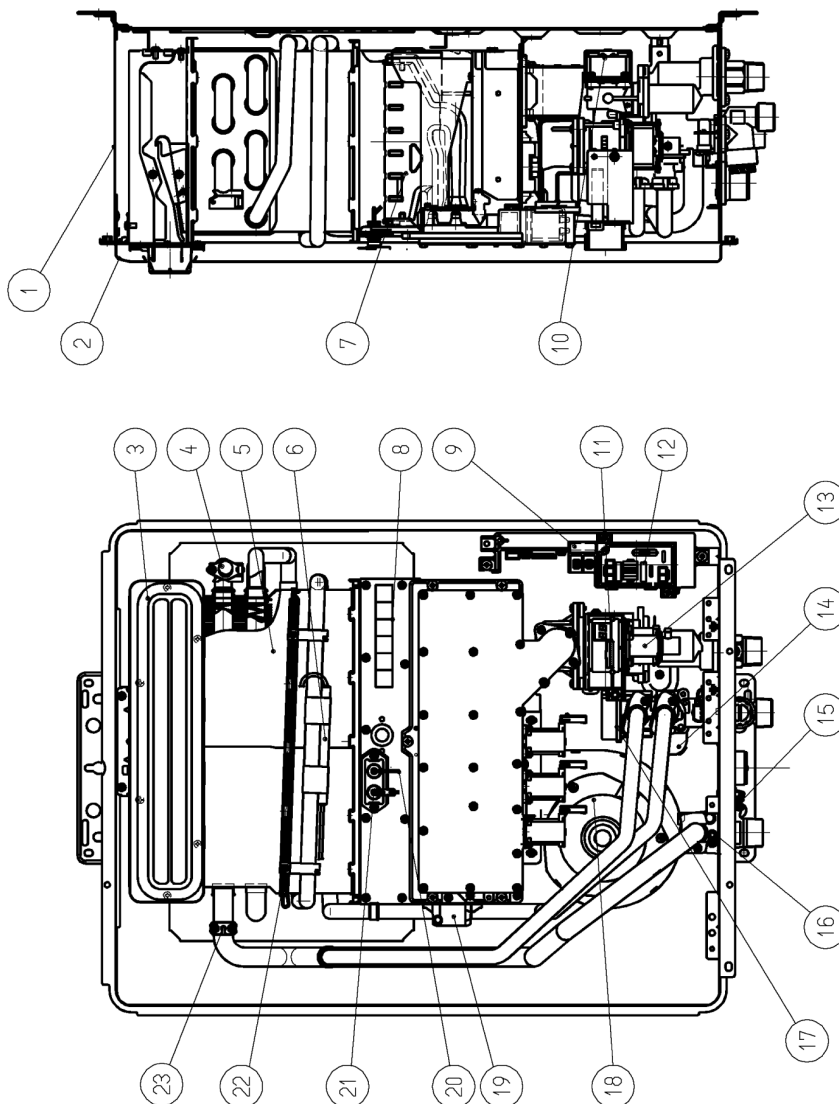

Figure 2 - Non Solar Hot Water Systems

6. Cutaway Diagram

NO.	NAME	MATERIAL
①	CASING ASS'Y	HOT-DIPPED ZINC-COATED STEEL SHEET
②	FRONT PANEL	
③	FLUE OUTLET	STAINLESS STEEL
④	OVER HEAT SWITCH	
⑤	HEAT EXCHANGER	COPPER
⑥	ANTI-FROST HEATER (-AK,ZK ONLY)	
⑦	BURNER	STAINLESS STEEL
⑧	PANEL OF COMBUSTION CHAMBER	ALUMINUM COATED STEEL SHEET
⑨	PCB	
⑩	SOLENOID VALVE BODY	ALUMINUM CASTING
⑪	STATUS MONITOR (commercial model ONLY)	
⑫	SURGE PROTECTOR	
⑬	MODULATING SOLENOID VALVE	ALUMINUM CASTING
⑭	WATER FLOW CONTROL DEVICE	BRASS
⑮	PRESSURE RELIEF VALVE	BRASS
⑯	OUTGOING WATER TEMPERATURE THERMISTOR	
⑰	BY-PASS CONTROL DEVICE	BRASS
⑱	COMBUSTION FAN	
⑲	IGNITION	
⑳	ELECTRODE	
㉑	FLAME ROD	
㉒	THERMAL FUSES	
㉓	HEAT EXCHANGER THERMISTOR	



7. Operational Flow Chart

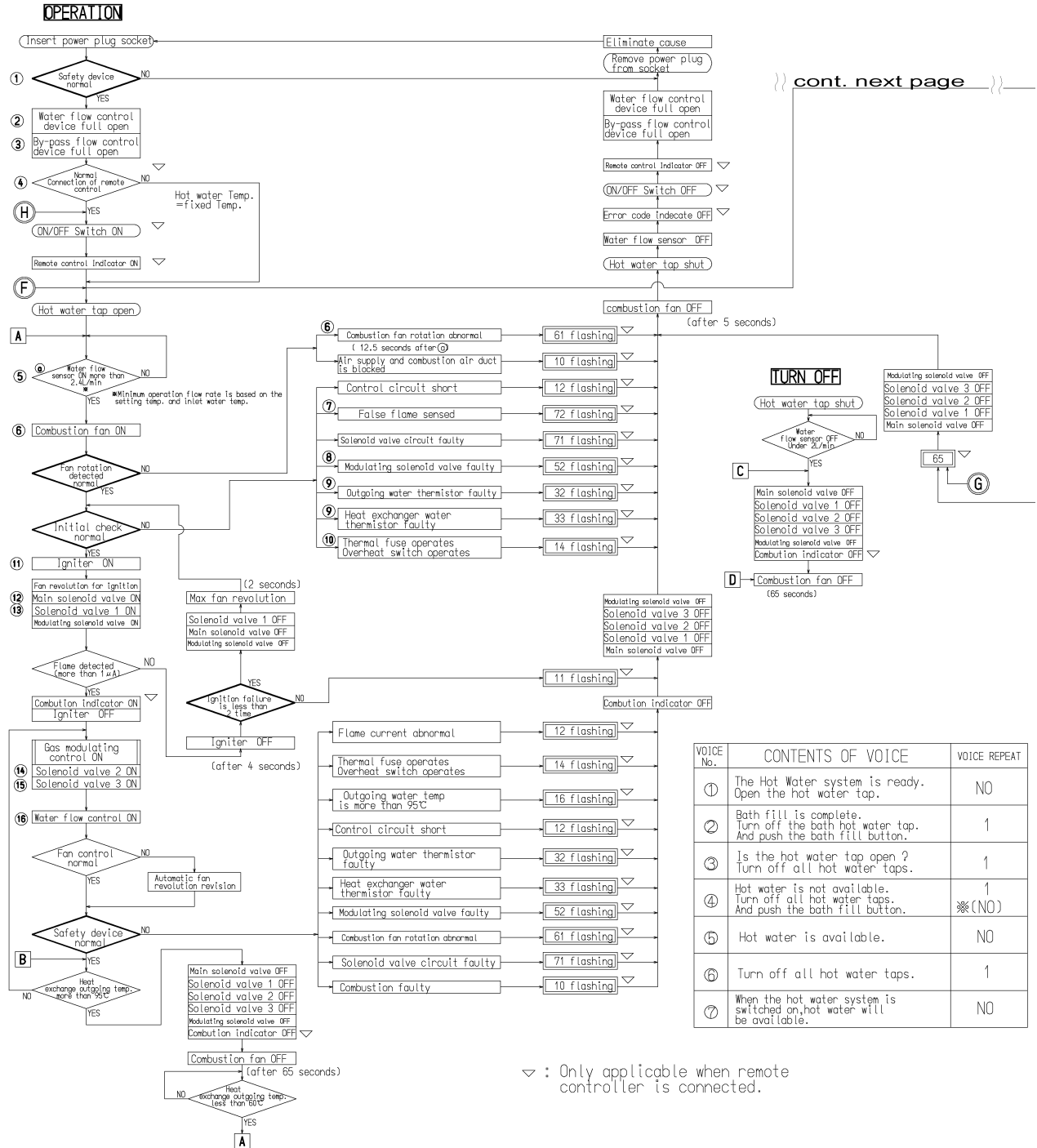

BATH FILL OPERATION
(Connection of BC-70)

PUSH THE BATH FILL SWITCH DURING THE OPERATION OF BATH FILL
(Connection of BC-70)

TURN OFF THE ON/OFF SWITCH DURING THE OPERATION OF BATH FILL
(Connection of BC-70)

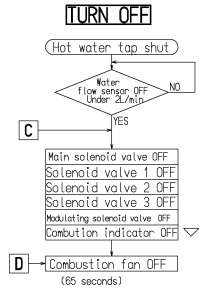
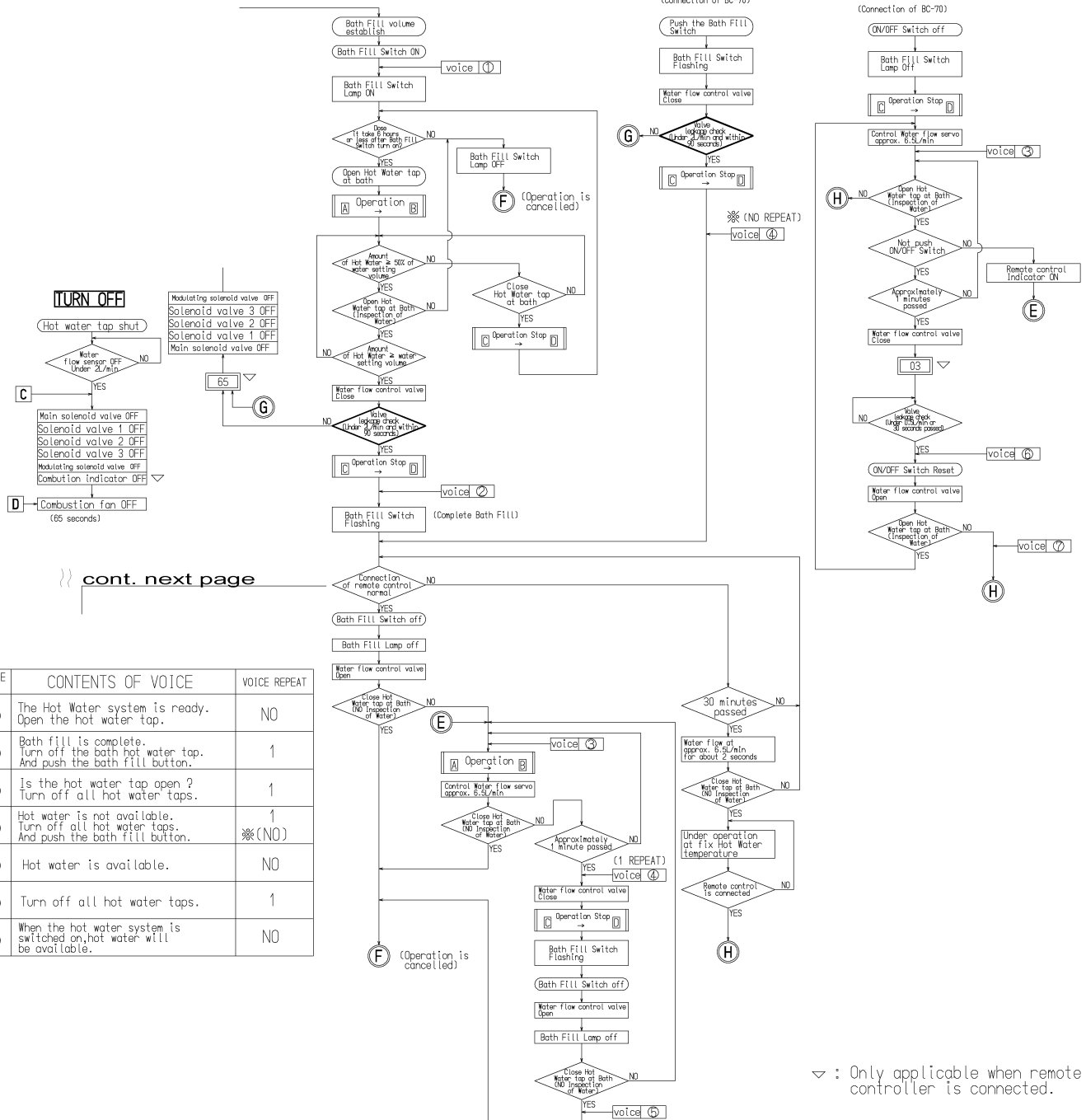

cont. next page

VOICE No.	CONTENTS OF VOICE	VOICE REPEAT
①	The Hot Water system is ready. Open the hot water tap.	NO
②	Bath fill is complete. Turn off the bath hot water tap. And push the bath fill button.	1
③	Is the hot water tap open? Turn off all hot water taps.	1
④	Hot water is not available. Turn off all hot water taps. And push the bath fill button.	1 ※(NO)
⑤	Hot water is available.	NO
⑥	Turn off all hot water taps.	1
⑦	When the hot water system is switched on, hot water will be available.	NO

▽ : Only applicable when remote controller is connected.

8. Operation Principles

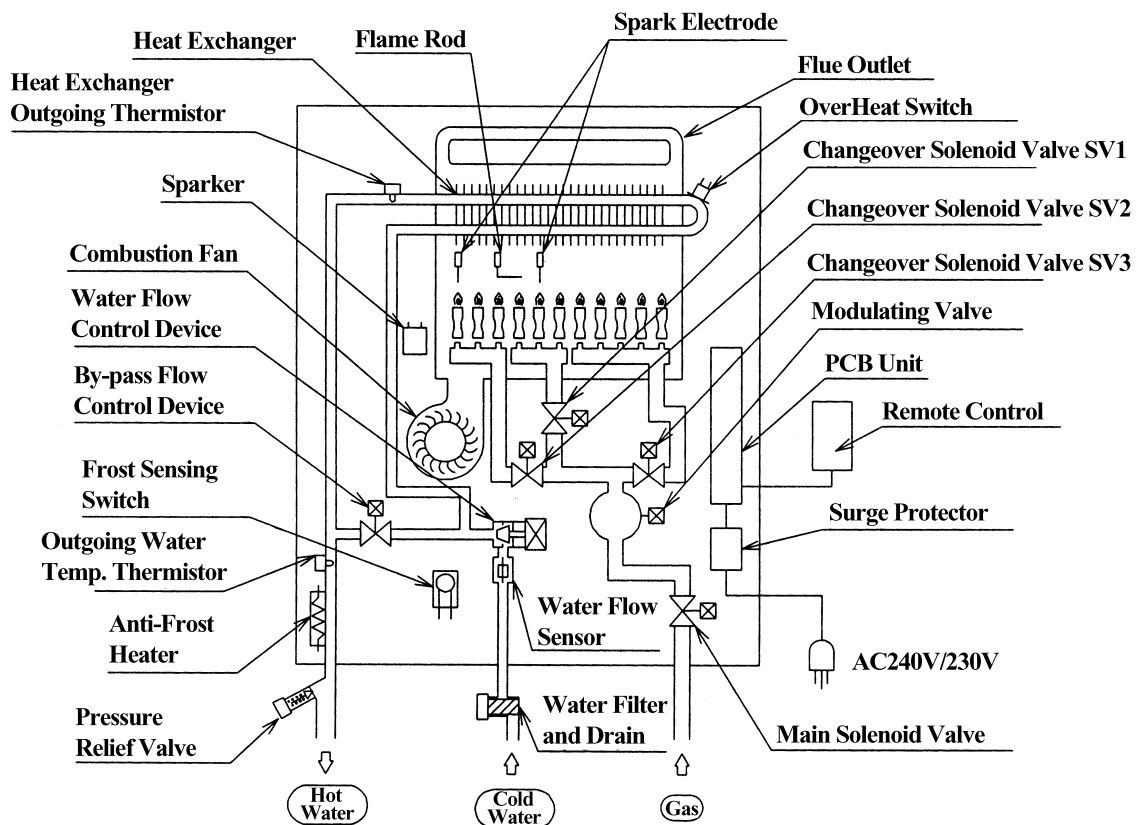

Hot Water Operation

1. Ignition

- Activate controllers (if fitted) and open the hot water tap (for full details regarding operation of controllers refer to the 'Customer Operating / Installation Manual' supplied with water heater).
- When water flows through the unit, the water flow sensor rotates and sends an electrical 'pulse' signal to the Printed Circuit Board (PCB). This signal is proportional to the water flow rate.
- The PCB sends electrical current to the combustion fan motor causing it to turn. The fan motor sends an electrical pulse signal to the PCB. If fan rotation is OK, the main solenoid and changeover solenoid valves open as required, the spark generator activates and the spark electrode ignites the burner.

2. Water Temperature and Flow

- The PCB will automatically control operation of the internal components to achieve the programmed temperature. When a high temperature rise is required, the PCB may cause the Water Flow Servo to close partially resulting in a lower flow rate to achieve the programmed temperature. This is a necessary operational feature of the unit.
- When operating in 'Bath Fill' mode, the signal from the water flow sensor is also used by the PCB to compute the volume of water that has been passed through the unit at any instant whilst the bath is filling.

3. Shut Down

- When operating in 'Bath Fill' mode, the PCB causes the Water Flow Servo to close when the programmed Bath Fill volume has passed through the unit. Alternatively, flow is stopped when the user closes the hot water tap.
- When water flow stops, the water flow sensor stops rotating and the pulse signal to the PCB stops. The PCB then causes the main solenoid and solenoid valves to close and the burner is extinguished. The combustion fan will continue to operate for some time to purge the combustion chamber.

9. Main Components

1) Printer Circuit Board (PCB)

- The Printed Circuit Board controls all operational functions including Air Supply Control, Gas Control, Water Flow Measurement, Water Flow Control, Combustion System and all sensors and safety devices.

2) Gas Flow Control

- During normal operation, the PCB keeps the main solenoid valve open whilst there is flow through the unit and the burner needs to be lit.
- Gas flow rate is controlled by the modulating valve assembly and changeover solenoid valves to always ensure constant outlet water temperature, regardless of flow rate or incoming water temperature.
- The modulating valve is electronically controlled by the PCB using signals from the water flow sensor, water flow control device, bypass flow control device, water temperature thermistors and combustion fan speed sensor. The modulating valve directs gas to the three changeover solenoid valves.
- The changeover solenoid valves direct gas to each of the burner banks independently. Any one, two or all of the solenoid valves may be open during operation.
- Gas flow is modulated by a combination of the modulating valve and changeover solenoid positions.
- The maximum gas rate is predetermined and the appliance cannot be overloaded when correctly installed.

3) Water Flow Control

- Water flow is detected by a turbine coupled to a magnetic pulse generating device. The magnetic pulses are detected and counted by the PCB. The PCB calculates the exact water flow from the frequency of pulses generated by the turbine, as well as the volume of water that has passed through the unit at any instant during 'Bath Fill' operation. A minimum flow rate of 2.7l/min. is required for the burner to ignite.
- Water flow control is achieved through the use of servo driven water flow and bypass valves. Both servo motors are controlled by the PCB. The 'Water Flow Valve' restricts the flow of water into the heat exchanger assembly if the programmed temperature cannot be achieved. Also, when the Bath Fill function is activated, flow of water is stopped when the bath is full. During normal operation, cold water from the inlet valve is mixed with hot water from the heat exchanger outlet. The 'Bypass Valve' mixes the correct proportion of cold and hot water to ensure accurate hot water delivery temperature over the available range of flow rates. The water flow and bypass valves are a combined assembly on the cold water inlet of the appliance.

4) Air Supply Control

- Air for combustion is supplied by a centrifugal fan driven by a variable speed DC motor. The to the motor is determined by the PCB based on water flow, delivered water temperature and programmed water temperature. The actual fan speed is monitored by a magnetic pulse counter. This counter emits a signal to the PCB. From the supplied to the DC motor and the fan speed signal, the PCB determines whether an error condition exists with the fan.

5) Combustion System

The combustion chamber is housed within the heat exchanger assembly and comprises:

- A multi chamber aluminium alloy manifold with a total of multiple injectors, arranged in multiple rows. The middle chamber houses eight injectors, the left chamber, twelve, and the right chamber, twenty four injectors. Gas flow to each chamber is controlled by an electronic solenoid valve (refer 'Gas Flow Control' above).
- A burner assembly comprising multiple identical modular stainless steel bunsen burners secured by an aluminised steel framework. The manifold is attached to the front of the burner module. Each bunsen burner is supplied by two injectors.
- A combustion chamber. Integrated into the combustion chamber front panel are the flame rod and ignition electrode(s).

10. Time Charts

Normal Combustion Sequence

REU-V3237 Series

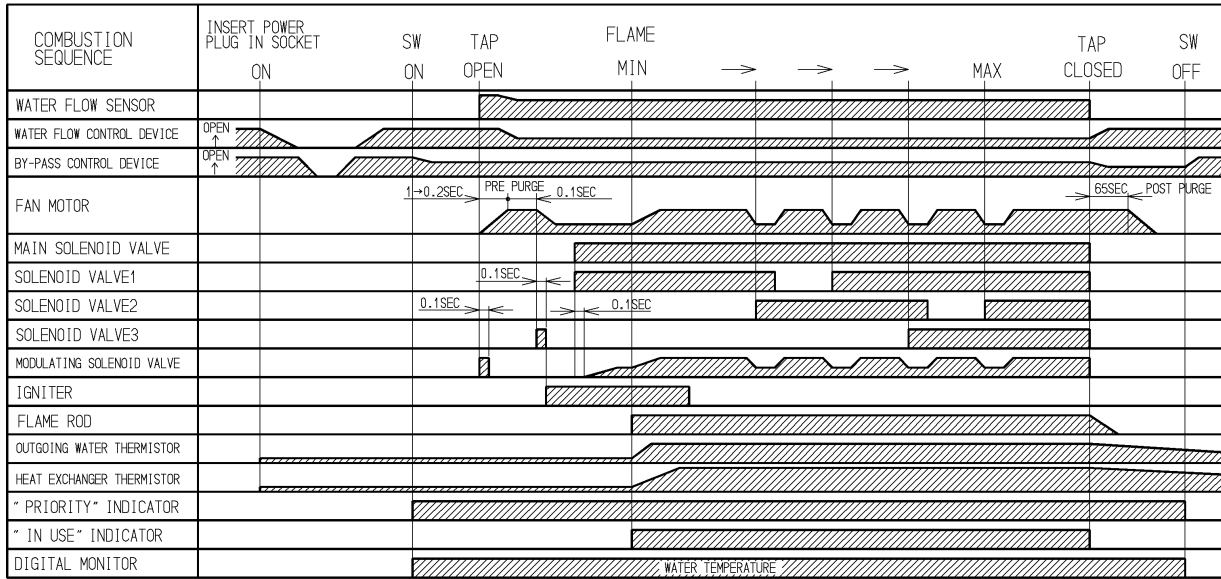

Error Sequence (Ignition/Flame Failure)

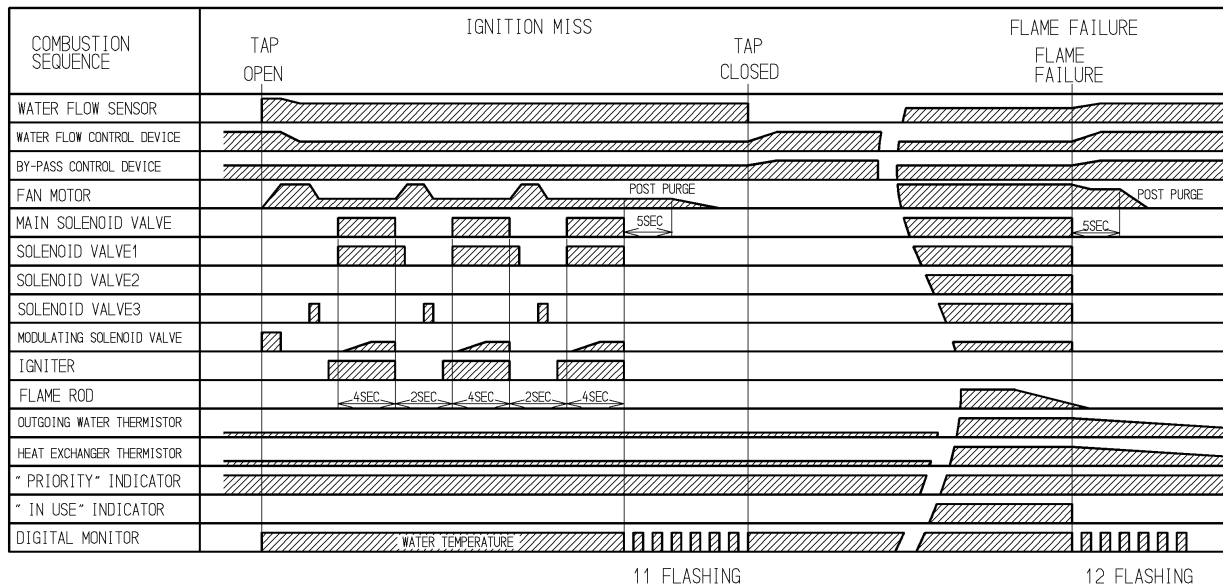

Pre-Purge Defect Sequence

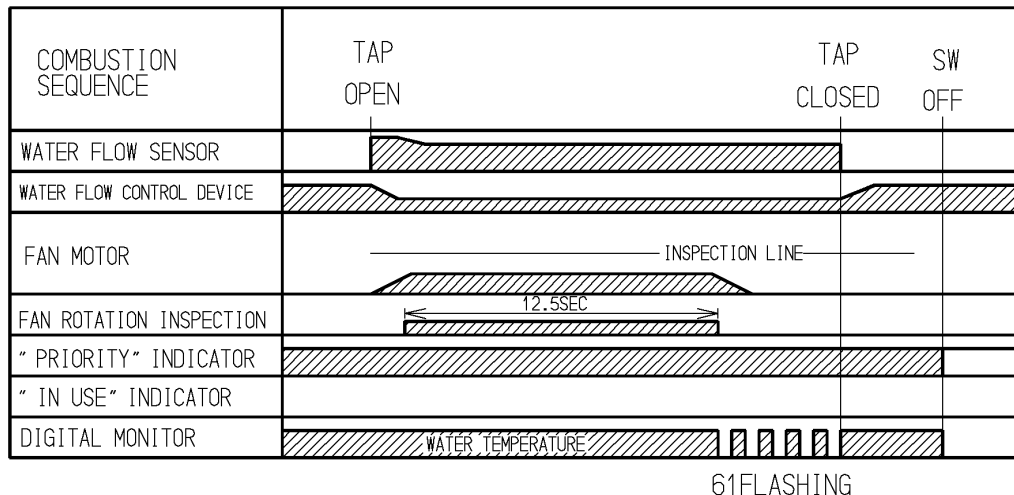

11. Wiring Diagram

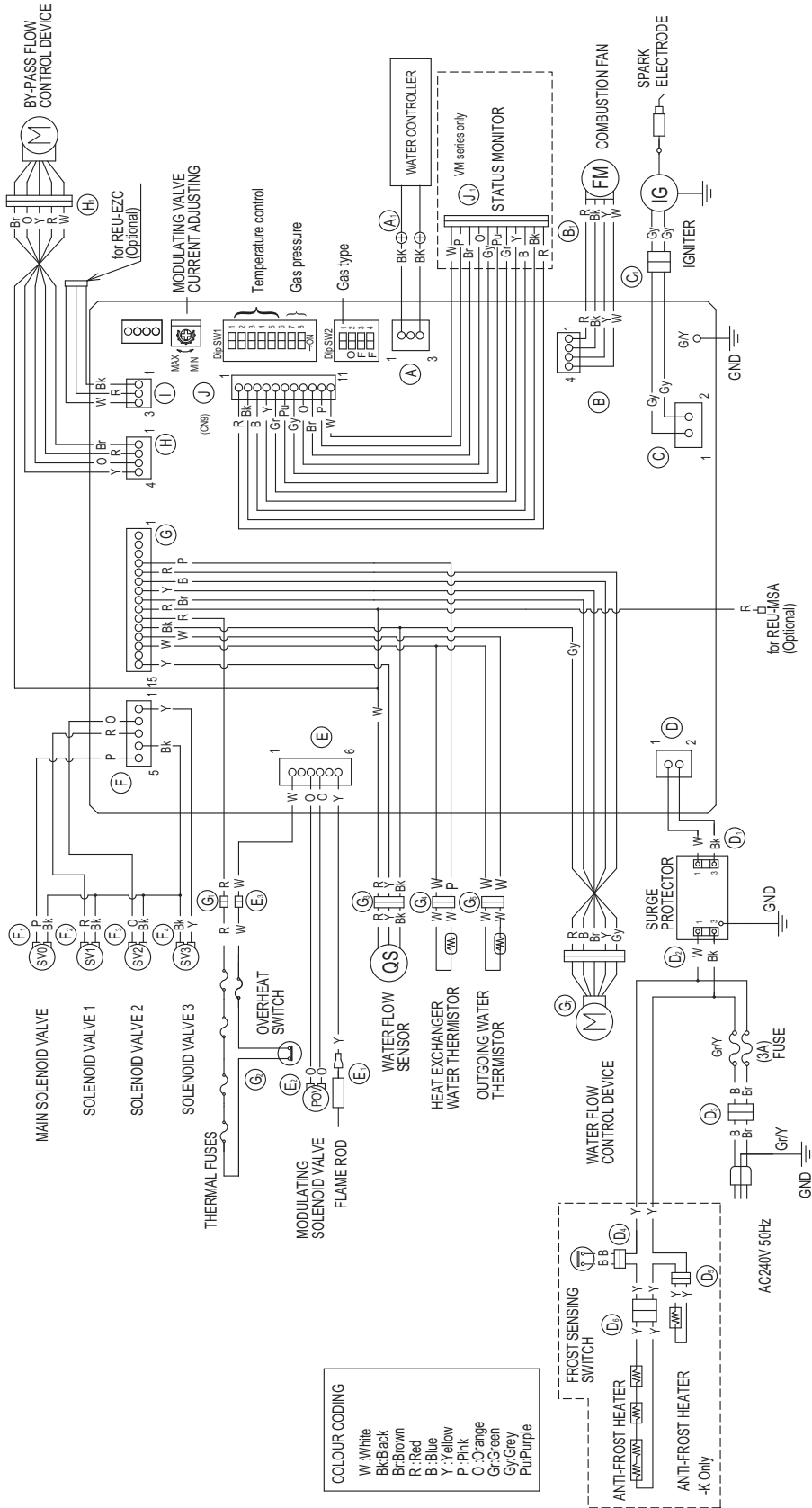

12. Diagnostics Points

FLOW CHART No.	COMPONENT	MEASUREMENT POINT		NORMAL VALUE	NOTE
		CN	WIRE COLOUR		
①	SURGE PROTECTOR	D ₁	B-Br	AC207~264V	
② ⑬	WATER FLOW CONTROL DEVICE	G ₆	R-B	DC11~13V	OPERATE ELECTRICITY
			Gy-O	DC11~13V	CONTROL ELECTRICITY
			Gy-Y	BELOW DC1V(LIMITER ON)	FULL OPEN POSITION
				DC4~6V (LIMITER OFF)	
Gy-Br	BELOW DC1V(LIMITER ON)	FULL CLOSE POSITION			
	DC4~6V (LIMITER OFF)				
③	BY-PASS FLOW CONTROL DEVICE	H ₁	Br-W O-W Y-W R-W GND	DC12V (OPERATING DC2~6V)	
				15~35Ω	
④	WATER CONTROLLER	A ₁	Bk-Bk	DC11~13V	
⑤	WATER FLOW SENSOR	G ₃	R-Bk	DC11~13V	ON2.7I/MIN (30Hz) OVER 1800PULSE/MIN OFF2.0I/MIN (20Hz) BELOW 1200PULSE/MIN
			Y-Bk GND	DC4~7V (PULSE 17~460Hz)	
⑥	COMBUSTION FAN	B ₁	R-Bk	DC6~45V	
			Y-Bk	DC11~13V	
			W-Bk GND	DC6~45V (33~400Hz)	
⑦	FLAME ROD	E ₁	Y-BODY EARTH	AC5~150V	AFTER IGNITION
			Y-FLAME ROD	OVER DC1μA	FLAME CONDITION
⑧	MODULATING VALVE	E ₂	P-P	DC2~15V 67~81Ω	
⑨	OUTGOING THERMISTOR	G ₅	W-W	15° C... 11. 4~ 14. 0kΩ 30° C... 6. 4~ 7. 8kΩ 45° C... 3. 6~ 4. 5kΩ 60° C... 2. 2~ 2. 7kΩ 105° C... 0. 6~ 0. 8kΩ	
⑩	HEAT EXCHANGER OUTGOING THERMISTOR	G ₄	W-P		
⑫	THERMAL FUSE	G ₁	R-R	BELOW 1Ω	
		E ₃	W-W		
⑬	IGNITER	C ₁	Gy-Gy	AC207~264V	
⑭	MAIN SOLENOID VALVE	F ₁	P-Bk	DC11~13V 37~43Ω	
⑮	SOLENOID VALVE 1	F ₂	R-Bk	DC11~13V 37~43Ω	
⑯	SOLENOID VALVE 2	F ₃	O-Bk	DC11~13V 37~43Ω	
⑰	SOLENOID VALVE 3	F ₄	Y-Bk	DC11~13V 35~41Ω	

13. Dip Switch Settings

Contact Rinnai for Dipswitch settings.

14. Fault Finding



If there is a fault with the appliance, and controllers are installed, a numerical fault code may appear on the digital display controller. If controllers are not installed, one may be fitted to find out the fault code. Fault finding without controllers (and thus fault codes) is possible but more time consuming.

To diagnose and rectify faults, the **Fault Finding Table** is used as illustrated below:

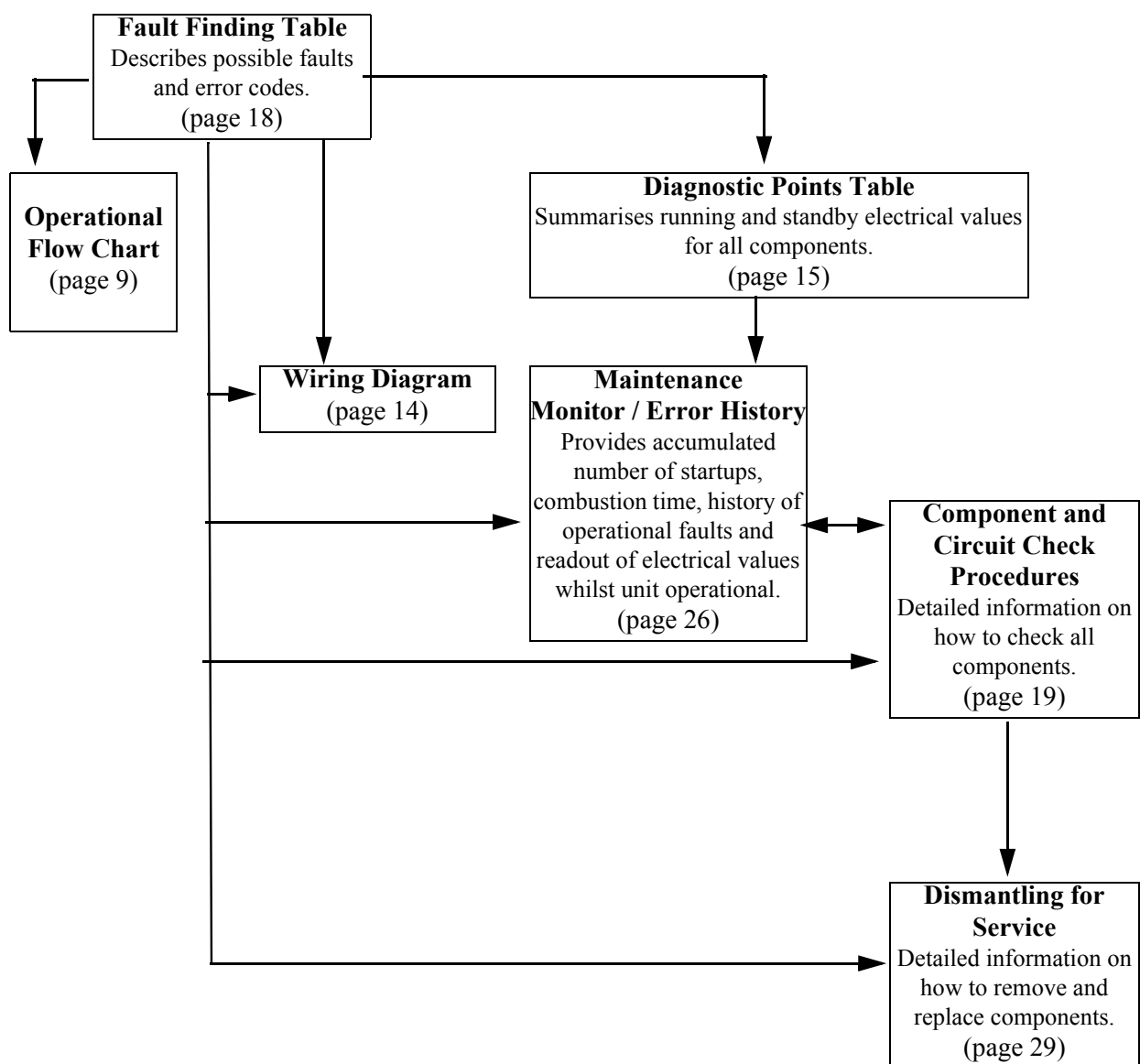

Fault Finding Table

Code on Controller	Fault	Action
03	Power interruption during Bathfill. Water will not flow when power restored.	1. Turn off all hot water taps. 1. Press the ON/OFF button on a controller twice.
10	Combustion fan current too high. Unit operates, then stops.	1. Check blockage of air intake/flue outlet. 2. Check combustion fan.
11	No ignition. Unit stops without flame igniting	1. Check gas supply 2. Check sparker unit 3. Check gas valves
12	Flame Failure / Earth Leakage	1. Check gas supply 2. Check flame rod 3. Check earth wire lead 4. Check remote control
14	Thermal fuse and/or overheat switch activated. Unit operates, then stops.	1. Check thermal fuse 2. Check overheat switch IMPORTANT- If thermal fuse or overheat switch were faulty : a. Check heater for damage b. Confirm "Gas Type" and "Combustion" dip switch settings c. Confirm test point pressures .
16	Over temperature warning. Unit operates, then stops.	1. Confirm "Gas Type" and "Combustion" dip switch settings 2. Confirm test point pressure 3. Check gas valves 4. Check water flow sensor 5. Check water flow servo 6. Check heat exchanger outlet temperature thermistor 7. Check hot water outlet temperature thermistor
32	Outlet water thermistor flow	Check hot water outlet thermistor
33	Heat exchanger thermistor error	Check heat exchanger thermistor
52	Modulating solenoid valve fault. Unit stops without flame ignition.	Check modulating solenoid valve
61	Combustion fan rotation error	Check combustion fan
65	Water flow control device error. Water flow is not controlled. Water temperature too low.	Check water flow servo
71	Solenoid valve circuit error. Unit does not operate.	Check gas valves
72	Flame rod circuit error. Unit does not operate.	Check flame rod
-	Appliance does not operate at all. No display on the water controllers (if fitted).	1. Check power cord plugged in and supply turned on. 2. Check power supply . 3. Check electrical fuse. 5. Check gas valves 6. Check sparker unit. 7. Check earth leads and connections. 8. Check for short circuits. 9. Check water controller(s) - if fitted.
-	No combustion despite remote control indicating that combustion is occurring - if water controller(s) fitted.	1. Check water flow sensor. 2. Check flame rod. 3. Check heat exchanger outlet thermistor. 4. Check hot water outlet thermistor. 5. Check combustion fan. 6. Check the sparker unit. 7. Check gas valves. 8. Check thermal fuse. 9. Check overheat switch. IMPORTANT - If thermal fuse or overheat switch were faulty: a) check heater for damage; b) confirm "Gas Type" and "Combustion" dip switch settings; c) confirm test point pressure.
-	Combustion stops during operation.	1. Check gas supply 2. Check flame rod 3. Check earth leads and connections.
-	Cannot adjust the hot water temperature via the controller(s) - only if water controller(s) fitted.	1. Check hot water outlet thermistor. 2. Check heat exchanger outlet thermistor. 3. Check gas valves 4. Check water flow servo. 5. Check bypass servo.
-	Anti-frost heater does not operate.	1. Check anti-frost heater components 2. Check frost sensing switch

15. Component and Circuit Checks



<p>1. Combustion Fan Circuit (B₁)</p> <ul style="list-style-type: none">• Check the Motor• Check the combustion fan if the error indicator displays “61”.• Measure voltages between Black and Red of the PCB connector (B₁). <p><i>Normal:</i> DC6~45V (when fan ON) DC0V (when fan OFF) If normal proceed to check the rotation sensor Faulty: Replace PCB</p>
<p>2. Check for the Fan Rotation Sensor</p> <p>a.) Measure voltages between Black and Yellow of connector (B₁).</p> <p><i>Normal:</i> DC11~13V If normal, proceed to b).</p> <p><i>Faulty:</i> Replace PCB.</p> <p>b.) Measure voltages between Black and White of connector (B₁).</p> <p><i>Normal:</i> DC6~45V If normal, proceed to Igniter Circuit 3. <i>Faulty:</i> Replace Combustion Fan.</p>
<p>3. Igniter Circuit (C₁)</p> <p>a.) Measure voltage between Grey and Grey of connector (C₁).</p> <p><i>Normal:</i> AC207-264V If normal, proceed to b). <i>Faulty:</i> Replace PCB.</p> <p>b.) Disconnect connector (C₁) and measure resistance between both terminals of the sparker.</p> <p><i>Normal:</i> > 1MΩ If normal and not sparking adjust or replace ignition plug.</p> <p><i>Faulty:</i> Replace Sparker.</p>

4. Main Solenoid Valve (F₁) Circuit

Check the main solenoid if error indicator "11" is displayed.

a.) Disconnect Main Solenoid connector and measure resistance between Pink and Black wires.

Normal: 37~43 Ω

If normal, proceed to b).

Faulty: Replace Main Solenoid.

b.) Measure voltage between Pink-Black of Main Solenoid connector.

Normal: DC11~13V

If normal, proceed to Solenoid Valve F₂

Faulty: Replace PCB.

4b.Solenoid Valve 1 (F₂) Circuit

Check Solenoid 1 if error indicator "11" is displayed.

a.) Disconnect Solenoid 1 connector and measure resistance between Red and Black wires.

Normal: 37 ~ 43 Ω

If normal, proceed to b).

Faulty: Replace Solenoid 1.

b.) Measure voltage between Red and Black of Solenoid 1 connector.

Normal: DC 11 ~ 13V

If normal, proceed to Solenoid Valve 2 (F₃) Circuit

Faulty: Replace PCB.

4c. Solenoid Valve 2 (F₃) Circuit

a.) Disconnect Solenoid Valve 2 connector and measure resistance between Orange and Black.

Normal: 37 ~ 43 Ω

If normal, proceed to b).

Faulty: Replace Solenoid Valve 2.

b.) Measure voltage between Orange and Black of Solenoid Valve connector.

Normal: DC 11 ~ 13V

If normal, proceed to Thermal fuse Circuit.

Faulty: Replace PCB.

4d.Solenoid Valve 3 (F₄) Circuit

a.) Disconnect Solenoid connector, measure resistance between Yellow and Black wires.

Normal: 35 ~ 41 kΩ

If normal, proceed to b).

Faulty: Replace Solenoid Valve 3.

b.) Measure voltage between Yellow and Black of Solenoid valve connector.

Normal: DC11 ~ 13 V

If normal, proceed to Modulating valve circuit.

Faulty: Replace PCB.

4e.Modulating Valve (E₂) Circuit

a.) Disconnect Modulating Valve terminal & measure resistance between pink terminals.

Normal: 67 ~ 81Ω

If normal, proceed to b.

Faulty: Replace Modulating Valve.

b.) Measure voltage between Pink and Pink wires of Modulating Valve terminal.

Normal: DC2 ~ 15V

If normal, proceed to c).

Faulty: Replace PCB.

c.) Check the gas secondary pressure change when set temperature on the remote control changes from 37 to 55 °C.

Normal: If secondary pressure changes, go to Water Flow Servo Circuit.

Faulty: Replace Modulating Valve.

5. Flame Rod Circuit (E₁)

- Operate appliance and check flame rod (E₁).
- Check Dc current flow between yellow flame rod wire and earth is over DC1μA.
- Disconnect flame rod terminal (E₁), and re-operate appliance.
- "72" indicated:- Proceed to **c**).
- "72" is not indicated:- check for electrical leaks from the flame rod circuit.
- Measure voltage between flame rod terminal (E₁) and appliance earth.

Normal: >1MΩ

- If normal, Check all power inputs into PCB. If power inputs okay replace PCB.
- If resistance abnormal replace flame rod.

a) Remove the Flame Rod terminal (E₁) repeat appliance operation procedure, if "72" is displayed again check the Hot water outlet thermistor.

If "72" is not displayed check current leakage from the Flame Rod.

b) Measure voltage between body earth and Flame Rod terminal (E₁).

Normal: voltage AC5 ~150V

If normal, check all power inputs into PCB. If power inputs okay replace PCB.

Faulty: Replace Flame Rod.

c) Check if the Flame Rod is securely fitted.

Normal: Check all power inputs into PCB. If power inputs okay replace PCB.

Faulty: Adjust the fitting of the Flame Rod.

- Check all appliance earth connections are clean and secure.

6. Earth Lead

Confirm the Earth Lead connection is secure (at round terminal), and check for broken or short circuits in the lead.

If normal, check other possible causes for flame failure (is gas valve open?, is the filter blocked? etc.).

If faulty, tighten the earth lead, PCB, power cord and surge arrester.

7. Overheat switch and thermal fuse circuit

1. Disconnect overheat switch terminals (G_2) and measure resistance between overheat switch terminals (G_2).

Normal: $< 1 \Omega$

If not normal replace overheat switch.

If normal reconnect overheat switch terminals (G_2) and proceed to step 2.

2. Disconnect relay connectors G_1 and E_3 and measure resistance between the white and red wires.

Normal: $< 1 \Omega$

If not normal replace thermal fuse.

If normal replace PCB

Note: If thermal fuse or overheat switch were faulty:

- a) Check heater for damage.
- b) Confirm gas type and combustion dipswitch settings.
- c) Confirm test point pressure.

8. Water Flow Sensor (G_3)

- a.) Measure voltage between Red - Black of relay connector (G_3).

Normal: DC 11~13V

If normal, proceed to b.

Faulty: Replace PCB.

- b.) Measure voltage between Yellow - Black of relay connector (G_3).

Normal: DC 4~7V

If normal, proceed to 2.

Faulty: Replace water flow sensor.

Note: For controller readout of water flow whilst operational refer maintenance monitor (chapter 15.) No. 1 .

9. Water Flow Control Device (G₆)

a.) Disconnect relay connector (G₆), and measure resistance between Red and Blue of Water Flow Servo.

Normal: 10~30Ω

If normal, proceed to b.

Faulty: Replace Water Flow Servo and Water Flow Sensor.

b.) Disconnect relay connector (G₆), and measure voltage between Orange (+) and Grey (-) on PCB unit side.

Normal: DC11~13V

If normal: proceed to c).

Faulty: Replace PCB unit.

c.) Measure voltage between Brown and Grey with relay connector (G₆) connected (with no water flowing, water flow servo fully open).

Normal: DC4~6V

Faulty: Replace Water Flow Servo with Water Flow Servo.

d.) Measure voltage between Yellow and Grey with relay connector (G₆) connected (with no water flowing, water flow servo fully open).

Normal: < DC1.0V

Faulty: Replace Water Flow Servo and Water Flow Sensor.

10. Heat Exchanger Outlet Thermistor Circuit (G₄)

Check Heat Exchanger Outlet Thermistor if error indicator "33" is displayed. Disconnect relay connector (G₄) and measure resistance between White and Pink.

Circuit Break: Resistance > 1MΩ

Short Circuit: Resistance < 1Ω

If normal, proceed to Water Flow Servo Circuit

If *faulty*, replace Heat Exchanger Outlet Thermistor.

Note: For controller readout of thermistor temperature whilst operational refer maintenance monitor (chapter 15) No. 11.

Refer circuit diagram diagnostic points for normal temperature versus resistance values.

11. Hot Water Outlet Thermistor Circuit (G₅)

Check Hot Water Thermistor if error code 32 is displayed.

Disconnect relay connector (G₅) and measure resistance White - Pink.

When disconnected: resistance >1MΩ

When short circuit: resistance > 1 Ω

Normal: Check Heat exchanger outlet thermistor.

Faulty: Replace hot water outlet thermistor.

Refer circuit diagram diagnostic points for normal temperature versus resistant values.

If normal proceed to Flame Rod circuit.

Faulty: Replace the Hot water Outlet Thermistor.

Note: For controller readout of thermistor temperature whilst operational refer maintenance monitor (chapter 15) No. 2.

Refer circuit diagram diagnostic points for normal temperature versus resistant values.

12. Surge Protector (D₁) and Electric Fuses

- a) Check the electrical fuses between (D₃) and (D₂). Normal resistance across fuse < 1 Ω. If blown, replace with fuses of correct rating (240V, 3A). If OK go to b).
- b) Check supply voltage at (D₁). Voltage between white and black wires 207-264V. If supply voltage incorrect check power supply to appliance. If OK go to c).
- c) Check voltage at (D₂). Voltage between white and black wires 207-264V. If voltage is zero repeat a). If fuses are OK replace surge protector.

13. Bypass Flow Control Device (H₁)

- a.) Measure working voltage while relay connector (H₁) is connected.

Normal:

CN	Wire Colour	Value
H ₁	Br - W	DC 2 ~ 6V
	O - W	
	Y - W	
	R - W ^{GND}	

Faulty: Replace PCB.

- b.) Disconnect relay connector (H₁) and measure resistance.

Normal:

CN	Wire Colour	Value
H ₁	Br - W	15 ~ 35Ω
	O - W	
	Y - W	
	R - W ^{GND}	

If normal, proceed to a).

Faulty: Replace Bypass Servo.

14. Anti-frost Heater Circuit (D₅ and D₆)

- a) Disconnect relay connector (D₅) & measure resistance between yellow wires on the inlet valve frost heater at the frost heater side. Normal 53 Ω. If normal proceed to b).

Faulty: Replace valve anti frost heater.

- b) Disconnect relay connector (D₆) and measure resistance between the yellow wires on the pipe frost heater at the frost heater side. Normal 618 Ω.

Faulty: Replace valve anti frost heater.

15. Frost Sensing Switch (D₄)

Disconnect relay connector (D₄) and measure resistance between yellow and yellow wires. At room temperature resistance should be > 1M Ω. Cool switch to below 2°C then measure resistance. Resistance should be < 1M Ω.

Faulty: Replace frost sensing switch.

16. Gas Pressure Setting Procedure



Refer separate Rinnai document behind front cover of appliance.

17. Gas Conversion Procedure



Refer separate document available from Rinnai.

18. Maintenance Monitor / Error History

Wireless Controllers



Maintenance Function - Wireless Controller Transceiver

- 1.) Press maintenance button once.
- 2.) Temperature light (orange) will illuminate & the Led display will show current water temperature in heat exchanger.
- 3.) Press maintenance button again.
'Volume' light - (orange) will illuminate. Led display to show l/min water flow through the Infinity.
- 4.) Press maintenance button again and the previous 10 error codes will be displayed.



First number shown on Led display will be 1 - followed by error code then 2 and the error code.

If error code reads — —, it means there was no error recorded.

Press maintenance button again to return to transceiver to normal mode.

This feature is available where the appliances are connected with a deluxe controller This will enable service personnel to locate the maintenance history and faulty components, with the appliance in operation.

NB. When the maintenance information, error history is shown, use only one controller. If two or more water controllers are used at the same time, it may not operate correctly.

To display Maintenance Information

1. With the controller in the "OFF" position press the Water Temperature "DOWN" (Cooler) button while holding the "ON/OFF" button to activate the maintenance monitor. Press the "ON/OFF" button a second time to set the controller in the "ON" mode. This feature can now be used with the appliance in operation.
2. The maintenance number will be shown in the Water Temperature display.
3. Data will be shown in the Clock display.
4. To select the required maintenance number, press the Water Temperature "UP" and "DOWN" buttons.

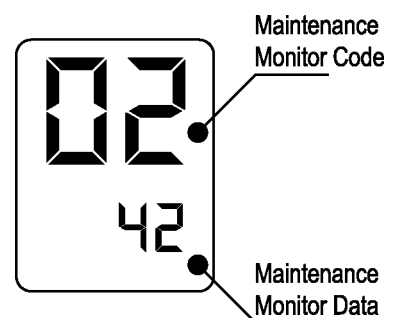

Display Monitor Contents			
No.	Contents	Units	Data Range
01	Water flow sensor recognition flow (Example 123 = 12.3L/min).	0.1L/min	0~400
02	Hot water Outlet thermistor temperature (Example 20 = 20°C)	°C	0~999
03	Hot water combustion time (Example 6 = 600 hours)	100 hours	000~999
04	Hot water operation frequency (Example 6 = 600 Operations)	100	0~999
05	Hot water fan frequency	Hz pulses/sec	0~999 * Note 1

***Note 1 Fan Frequency rpm Conversion**

$$(rpm) = (Hz) \times 15$$

06	Water control connection	none	0 or 1 * Note 2
----	--------------------------	------	------------------------

***Note 2 Water Control Connections**

Bathroom Controller		Controls connected	Display
Additional controller	Kitchen controller	No	“0”
“0”	“1”	Yes	“1”

07	Water flow servo present recognising positioning	None	0~2 * Note 3
----	--	------	---------------------

***Note 3 Water Flow Servo Positioning**

Servo Position	Open	Centre	Closed
Display	“1”	“0”	“2”

08	Inlet water temperature (PCB recognition value) (Example 25 = 25°C)	°C	0 ~ 999
09	Hot water fan current flow value (Example 6 x 10 = 60 mA)	10 mA	0 ~ 999
10	Bath fill amount (this counts the litres during bath fill operation).	Litres	0 ~ 999
11	Heat exchanger exit thermistor temperature (Example 55 = 55°C)	°C	0 ~ 999
12	Bypass servo present recognition positioning (Example 0 = Closed 250 = Half open 500 = Open)	Degrees	0 ~ 500

To return to normal operation

- Press the ON/OFF button again while holding down the Water Temperature "DOWN" (Cooler) button.

Error History

To Display Error Memory (History)

(This feature will show the last 10 faults in sequence)

1. Turn off at the ON/OFF button. (This can be done during operation)
2. Press the ON/OFF button while holding the Water Temperature "UP" (Hotter) button.
 - The Sequence will be shown in the Water Temperature display.
 - Error Code will be shown in the Clock display. (See service Manual for error codes).
 - Where there are less than a total of 9 errors, "FFF" or " - - " will be displayed in the Clock display.

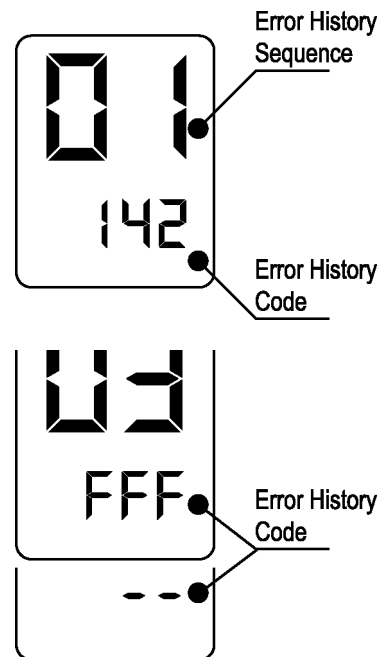

To return to normal operation.

- Press the ON/OFF button again while holding the Water Temperature "UP" (Hotter) button.
- This feature will automatically shut down after 3 minutes.

19. Dismantling for Service



240 volt potential exposure. Isolate the appliance and reconfirm with a neon screwdriver or multimeter.

NOTE: As this manual covers a wide range of models, some details of the dismantling procedure may be slightly different to those depicted in this manual.

<i>Item</i>	<i>Page</i>
1. Removal of the Front Panel	30
2. Removal of the PCB Unit	30
3. Removal of the Water Flow Sensor, Servo and Bypass Servo	30
4. Removal of the Sparkers	31
5. Removal of the Combustion Fan	31
6. Removal of the Hot Water Outlet & Heat Exchanger Outlet Thermistors	31
7. Removal of the Gas Inlet, Solenoids and Flame Rod	32
8. Removal of the Gas Control	32
9. Removal of the Heat Exchanger	33
10. Removal of the Thermal Fuse and OHS	33

Unless otherwise stated, re-assembly is the reverse of dismantling.

IMPORTANT

For some areas of dismantling you may need to isolate any or all of the following:

- * Isolate gas supply.
- * Disconnect electrical supply from wall socket.
- * Isolate water supply.
- * Drain **all** water from appliance.

1) Removal of the Front Panel

- a. Remove four (4) screws.



2) Removal of the PCB Unit

- a. Remove the front panel. (Refer Item 1.)
- b. Remove two (2) PCB unit fixing screws and pull out forward.

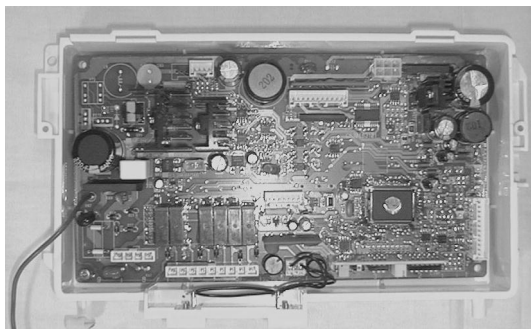
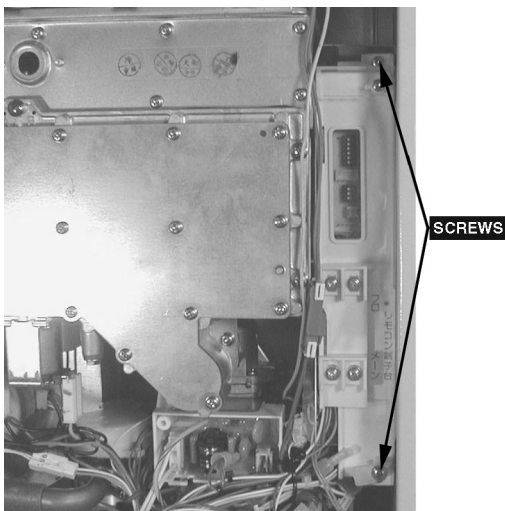

3) Removal of the Water Flow Sensor, Servo and Bypass Servo

- a. Remove the front panel. (Refer Item 1.)
- b. Remove two (2) screws and locking plates located on the water supply pipe and bypass pipe. Pull bypass pipe and water supply pipe forward to clear servo valves. Ensure O-rings are not lost or damaged.



4) Removal of the Bypass Servo

- c. Remove two (2) screws from the water flow servo body, and pull the bypass servo out forwards. Ensure O-rings are not lost or damaged..

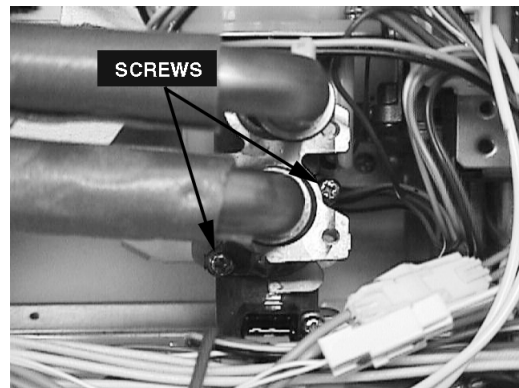

4) Removal of the Water Flow Servo with Sensor

- d. Remove four (4) screws from water supply connection body and take out the water flow servo with sensor and the water supply connection. Ensure O-rings are not lost or damaged..

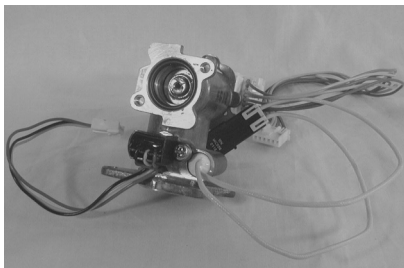
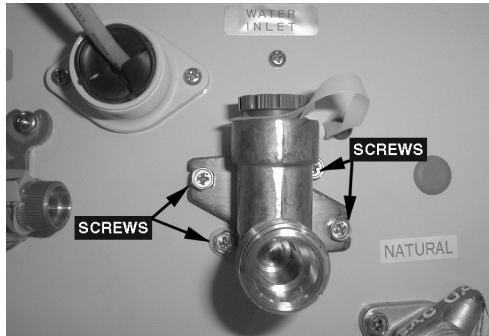

4) Removal of the Sparkers

- a. Remove front panel. (Refer Item 1.)
- b. Remove one (1) sparker screw, unplug high tension leads from spark ignitors, and take out the sparker.

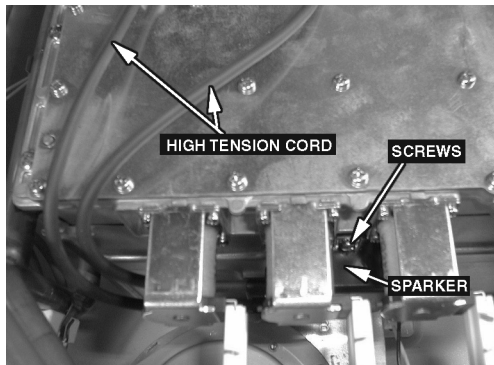

4) Removal of the Combustion Fan

- a. Remove front panel. (Refer Item 1.)
- b. Remove three (3) combustion fan screws, pull forward and slide to the side to remove fan.

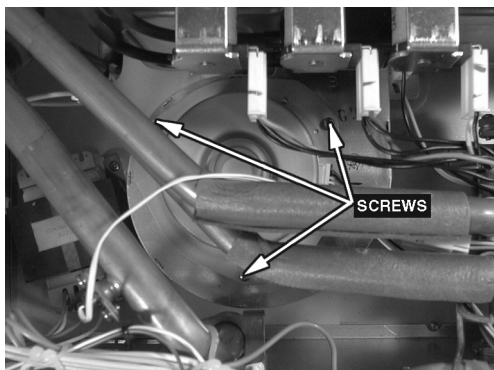

6) Removal of the Hot Water Outlet & Heat Exchanger Outlet Thermistors

- a. Remove front panel. (refer Item 1.)
- b. Remove two (2) thermistor screws and remove the Hot Water Outlet thermistor (HW), unplug.
- c. Remove two (2) thermistor screws and remove the Heat Exchanger Outlet thermistor (HE), unplug.

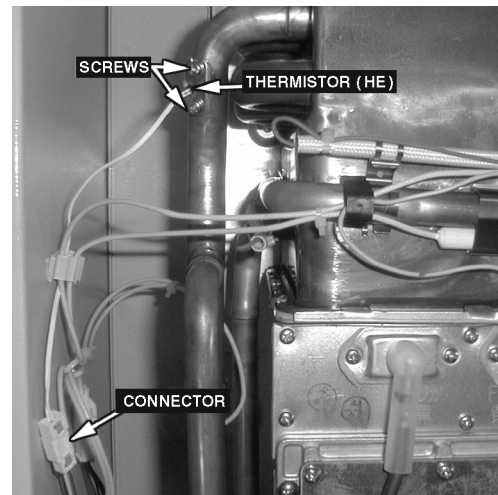
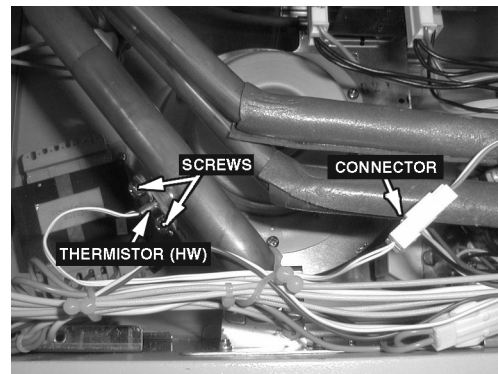

7) Removal of the Gas Inlet, Solenoid, Flame Rod

- a. Remove front panel (4 screws). (Refer Item 1.)
- b. Remove five (5) combustion screws located on outer edge of manifold plate.
- c. Remove two high tension leads from spark ignitors. Unplug wiring from solenoid coils.
- d. Remove two (2) manifold and gas control screws and take out by hand.

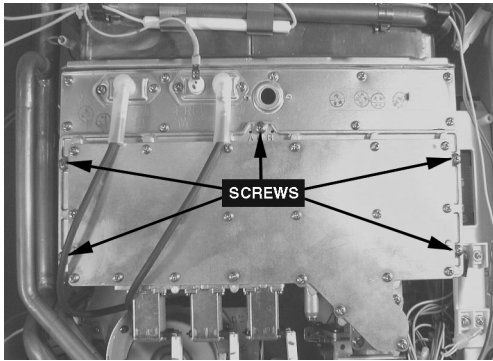

- e. Remove damper (3 screws).

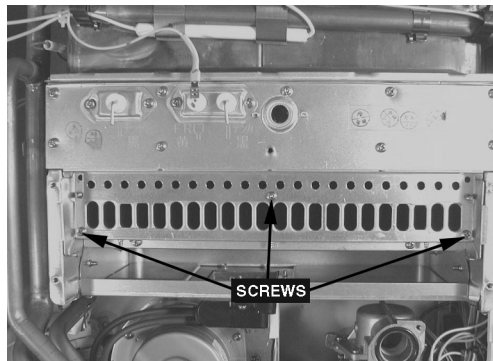

- f. Remove two (2) burner retaining screws, then remove combustion chamber front panel (9 screws).

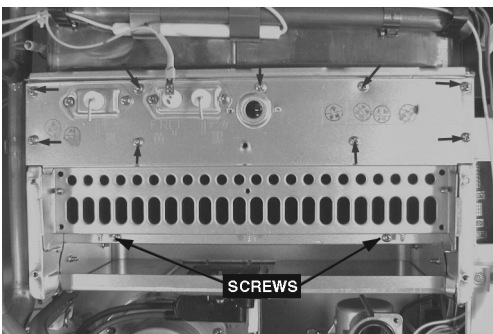

- g. Take out the burner unit.

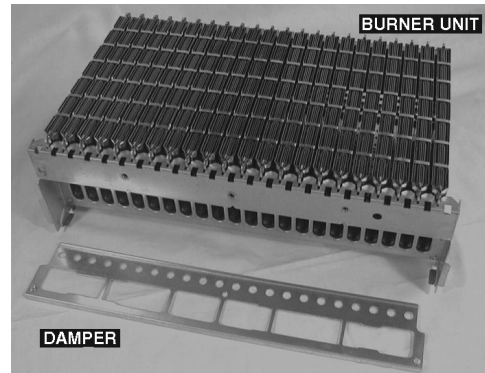

8) Removal of the Gas Control

- a. Remove front panel (4 screws). (Refer Item 1.)
- b. Remove the manifold. Refer to section 8) a. to d.
- c. Remove four (4) screws on gas connection inlet and gas control (assy), and pull out the gas connection. Handle O-ring carefully.

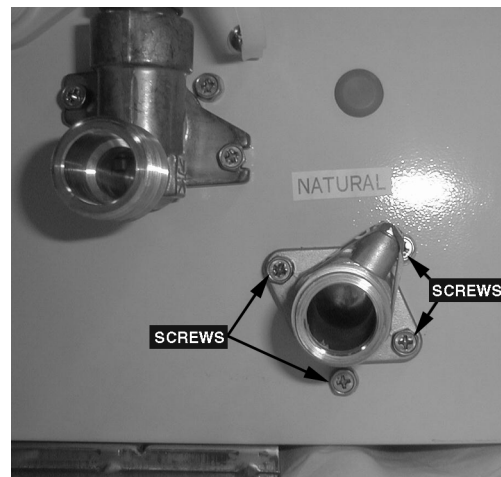

- d. Remove one (1) gas control (assy) screw and pull out gas control (assy).

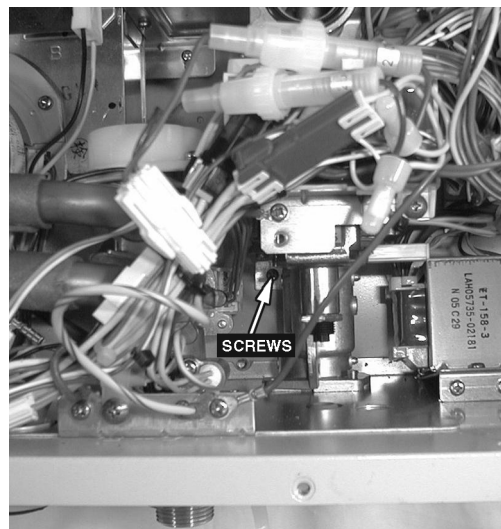

9) Removal of the Heat Exchanger

- a. Remove front panel (4 screws). (Refer Item 1.)
- b. Remove the PCB. (Refer Item 2.b.)
- c. Remove heat exchanger water supply pipe and bypass pipe. Refer to 3).
- d. Remove one (1) HEX HW pipe screw and pull the hot water pipe forward. Handle O-ring carefully.



- e. Remove the two (2) screws fixing the manifold and gas control.
- f. Remove four (4) heat exchanger unit screws.

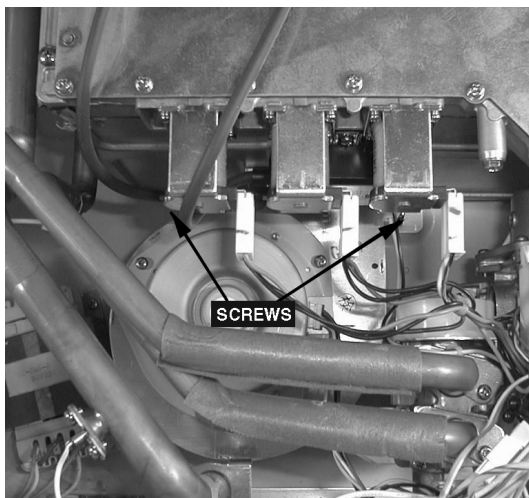

- g. Remove connectors of the fan motor, thermal fuse, flame rod etc.
- h. Pull the heat exchanger unit forward and out.

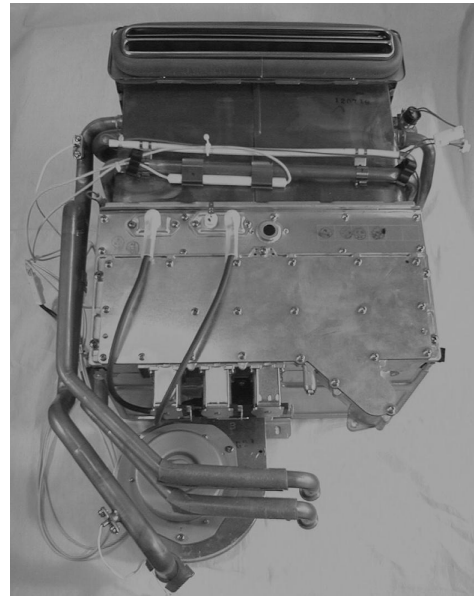

10) Removal of the Thermal Fuse and OHS

- a. Remove front panel (4 screws).
- b. Take out the heat exchanger unit. Refer to 10).
- c. Remove the thermal fuse.

Note: After replacing, install the thermal fuse as in the following diagrams.

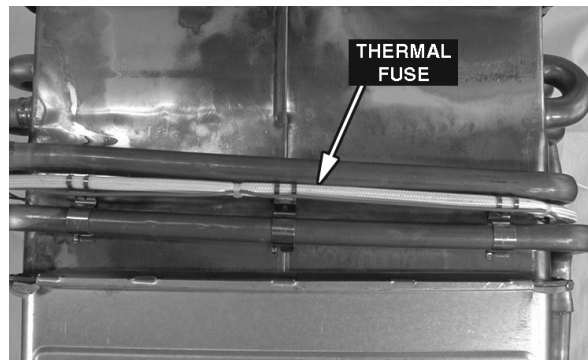

Heat Exchanger RHS

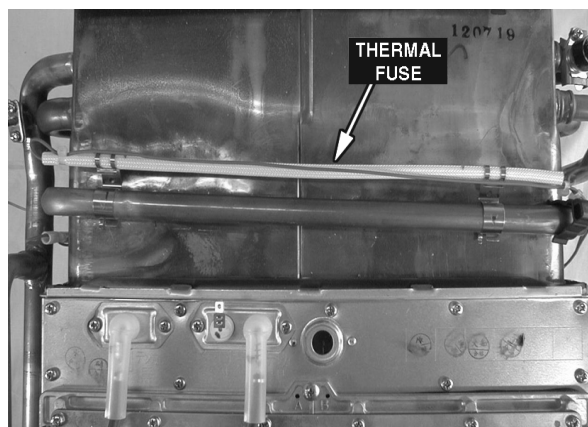

Heat Exchanger Front

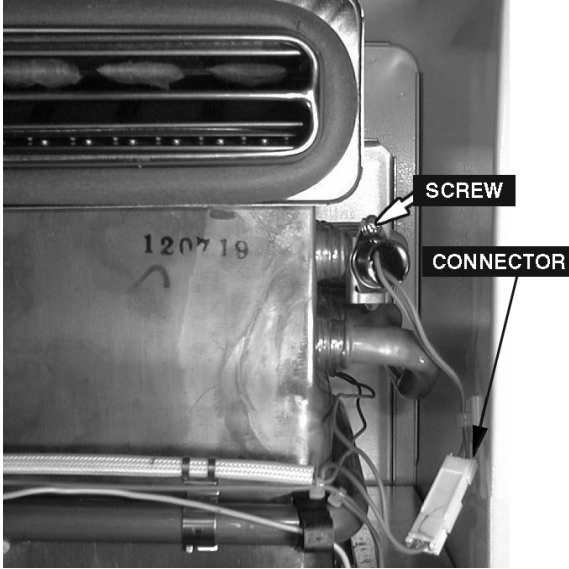

Heat Exchanger Back

- d. Remove one (1) screw of the bi-metal overheating switch.

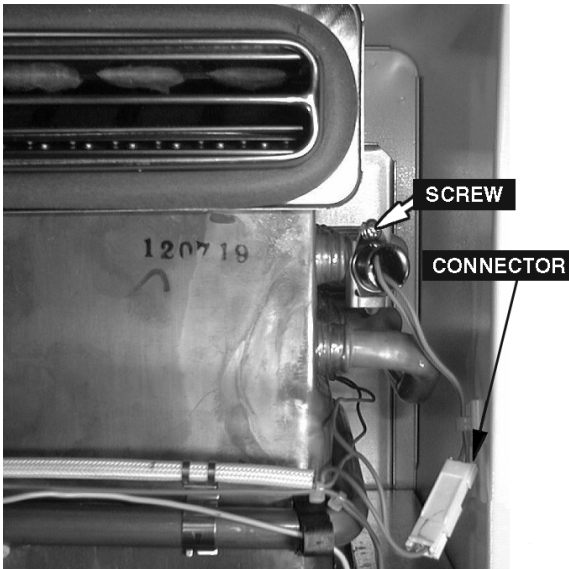

20. Parts List

Effective: 20/10/2006

REU-V237WG / REU-VM3237WC				REU-V3237WG-AK	REU-VM3237WC(65)-AK
No.	Part Name	RA Part No.	11 Digit Code		
001	MAIN BODY (OUTER CASE)	92093832	014-439-000	1	
001	MAIN BODY (OUTER CASE)	92093831	014-439-000		1
002	PLATE INSULATION		030-941-000	1	1
004	PANEL FRONT ASSEMBLY	92093378	019-3576000	1	
004	PANEL FRONT ASSEMBLY	92093379	019-3576000		1
007	BRACKET WALL	92093377	106-329-000	2	2
010	SEAL PANEL FRONT TOP	92086909	580-453-000	1	1
011	SEAL PANEL FRONT SIDE	92086917	510-903-000	2	2
012	CONNECTION REINFORCEMENT		044-154-000	1	1
013	BAG INSTALLATION MANUAL		600-051-000	1	1
014	BLIND GASKET		510-893-000	1	1
015	CABLE ENTRY (NEW) INF20	92073352	106-104-000	1	1
016	SEAL HARNESS EASY CONNECT	92099984	580-0105000	2	2
018	PLATE REINFORCEMENT		044-151-000	1	1
023	HARNESS EASY CONNECT	92099986	106-641-000	1	1
024	CONNECTION SUPPORT CLIP		538-840-000	1	1
100	INLET GAS 3/4	92081587	106-290-000	1	1
101	SCREW TEST POINT	90195157	501-275-005	2	2
102	GAS CONTROL ASSEMBLY	92086926	120-241-000	1	1
103	MANIFOLD LP	92095036	101-701-000	1	1
103	MANIFOLD NG	92095035	101-702-000	1	1
104	BURNER ASSY	92092213	000-140-000	1	1
105	DAMPER		140-775-000	11	11
107	BURNER CASE BOTTOM PLATE		004-564-000	1	1
108	BURNER CASE FRONT		098-985-000	1	1
109	PACKING		580-573-000	1	1
110	LEAN AND RICH BUNSEN BURNER		157-090-000	22	22
111	BURNER CASE REAR PANEL		098-986-000	1	1
113	COMBUSTIONS CHAMBER FRONT		019-3389000	1	1
114	COMBUSTION CHAMBER PACKING		580-574-000	1	1
115	ELECTRODE	92086974	202-156-000	1	1
116	ELECTRODE FR	92093640	230-057-000	1	1
117	PACKING ELECTRODE	92087015	580-0390000	1	1
118	ELECTRODE HOLDER RH	92087006	580-505-000	1	1
121	ELECTRODE SLEEVE	92087030	518-035-000	1	1
122	MAGNET VALVE COVER		098-0647000	1	1
123	COMBUSTION CHAMBER PACKING		092-046-000	1	1

REU-V3237WG / REU-VM3237WC

REU-V3237WG / REU-VM3237WC				REU- V3237WG-AK	REU- VM3237WC(65)- AK
No.	Part Name	RA Part No.	11 Digit Code		
124	COMBUSTION CHAMBER PACKING		092-047-000	1	1
125	HEAT EXCHANGER ASSY	92087049	314-696-000	1	1
131	EXHAUST FLUE	92095934	055-510-000	1	1
132	GASKET INNER FLUE	92096445	580-576-000	1	1
133	PACKING FLUE MAINBODY	92096452	580-681-000	1	1
150	FAN MOTOR	92095022	222-534-000	1	1
151	FAN CASING	92098862	035-867-000	1	1
	FAN COMB ASSEMBLY		222-614-000	1	1
153	BRACKET FAN		106-649-000	1	1
154	PACKING FAN BRACKET		580-580-000	1	1
400	INLET WATER 3/4	92099968	333-301-NPB	1	1
401	PLUG BAND		553-119-000	1	1
402	FILTER WATER 0 LARGE	92083773	196-062-000	1	1
405	WATER FLOW SENSOR	92087064	301-163-000	1	1
406	RECTIFIER		330-107-000	1	1
407	BY-PASS SERVO ASSY	92087072	301-158-000	1	1
408	STOP BRACKET		512-401-000	2	2
409	WATER FLOW SERVO COVER		098-1445000	1	1
410	OUTLET WATER 3/4	92093807	333-450-000	1	1
411	PLUG BAND		553-043-000	1	1
412	VALVE PRESS RELIEF	92081751	337-048-000	1	1
413	STOP BRACKET D		512-406-000	1	1
700	PCB MAIN	92087759	200-0471000	1	1
701	SURGE ARRESTOR	92093699	210-605-000	1	1
702	EC Cover		098-1869000		
703	PCB Cover-Side		098-1844000	1	1
704	IGNITOR BRACKET		538-0396000	1	1
705	SPARKER	92095026	261-157-000	1	1
706	LEAD HT	92092253	203-828-000	1	1
707	IGNITOR COVER		098-1845000	1	1
708	HEATER ANTIFROST	92093295	235-376-000	1	1
709	BRKT HEATER	92093301	538-493-000	2	2
710	HEATER FIXING PLATE		537-0440000	1	1
711	HEATER FIXING PLATE		537-215-000	1	1
712	HEATER VALVE		235-369-000	1	1
714	FUSE THERMAL	92090175	290-1273000	1	1
715	FIXING BAND A (F)		553-055-000	9	9

REU-V3237WG / REU-VM3237WC

No.	Part Name	RA Part No.	11 Digit Code	REU-V3237WG-AK	REU-VM3237WC(65)-AK
716	THERMISTOR	92095030	233-246-000	2	2
717	BRACKET FLAME ROD	92086388	508-836-000	1	1
718	SWITCH THERMAL	92097187	234-444-000	1	1
720	HARNESS FUSE	92094004	290-1396000		
721	HARNESS POWER	92095038	204-0015000	1	1
722	HARNESS SPARKER	92095039	290-1398000	1	1
723	HARNESS SENSOR	92095040	290-1383000	1	1
724	ELEC CORD	92089051	206-226-000	1	1
725	HARNESS REMOTE	92095041	290-1399000	1	1
730	BRACKET RELAY		537-0643000		1
731	RELAY	92095032	210-810-000		1
800	SCREW		501-889-000	3	3
800	TRUSS SCREW		501-973-010	1	1
801	RESIN WASHER		503-022-010	3	3
802	SCREW		501-0057000	2	2
803	PLASTIC WASHER		503-026-010	5	5
804	SCREW		501-0091000	8	8
805	SCREW		501-865-000	5	5
806	TAPPING SCREW		501-737-000	1	1
807	SCREW		501-0092000	5	5
808	SCREW		501-0064000	2	2
809	SCREW		501-0093000	3	3
810	THERMISTOR STOP SCREW		501-295-000	1	1
811	O RING GAS CON	92072859	520-043-010	1	1
812	O RING IN/OUT WATER	92071182	520-049-010	3	3
813	O RING HEAT EX INLET	92062199	520-048-010	1	1
814	O RING HEAT EXCH	92062207	520-193-010	2	2
815	O RING PRESS VALVE	92062348	520-281-010	1	1
816	O RING THERMISTOR	92062249	520-209-010	2	2
817	O RING GAS MANIFOLD	92075126	580-202-000	1	1
818	O RING (S-4) TEST POINT	90195165	520-300-010	1	1
821	HEXAGON HEAD SCREW		501-395-000	1	1
822	SCREW		501-799-000	4	4
823	HEXAGON SCREW		511-119-000	2	2
824	TRUSS FT SCREW		501-403-000	3	3
888	OPERATION MANUAL(RAU)		623-344-700	1	1
889	INSTALLATION MANUAL		K23-397-800	1	1

21. Exploded Diagram

REU-V3237WG-AK / REU-VM3237WC(65)-AK

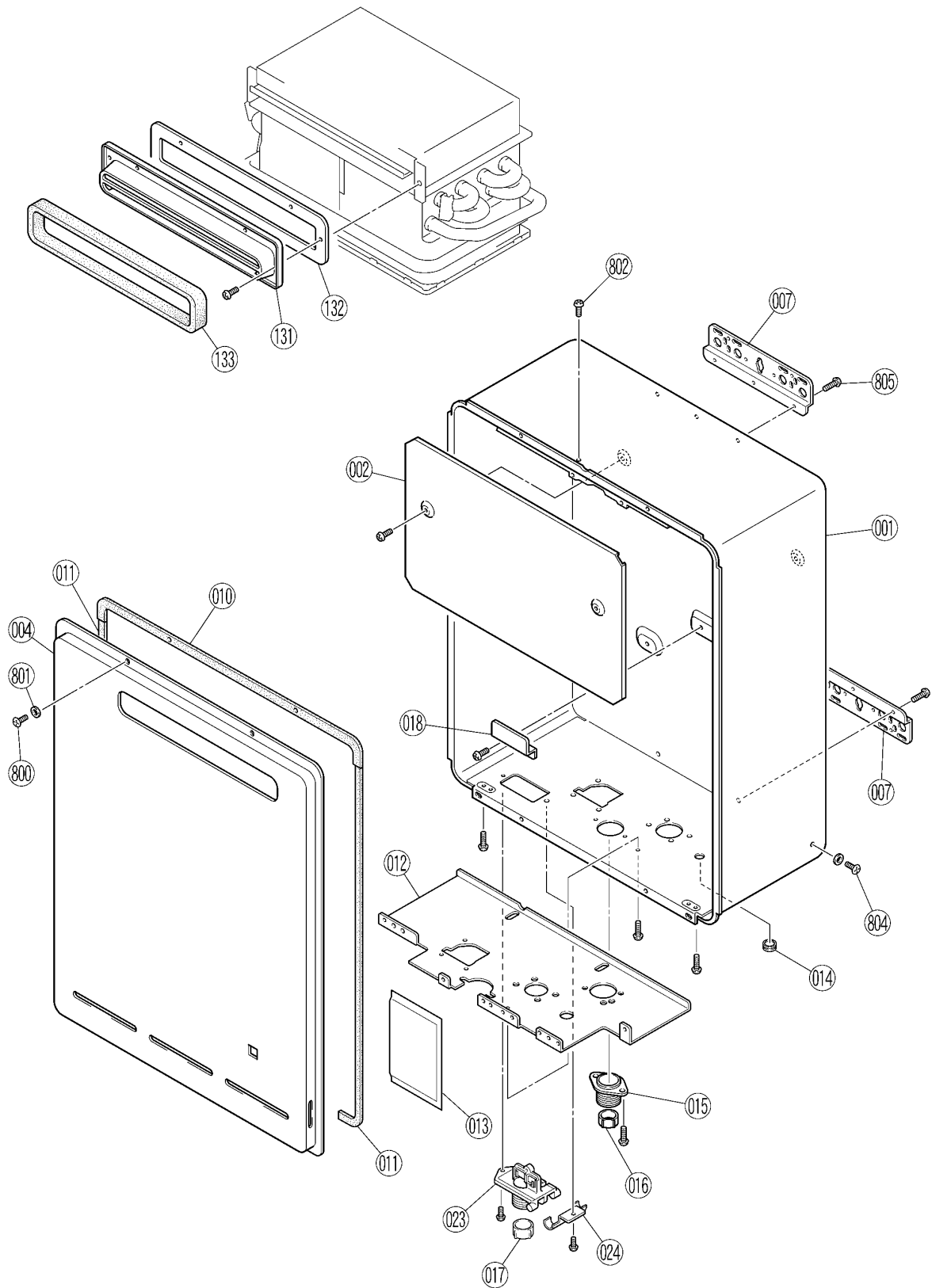

REU-V3237WG-AK / REU-VM3237WC(65)-AK

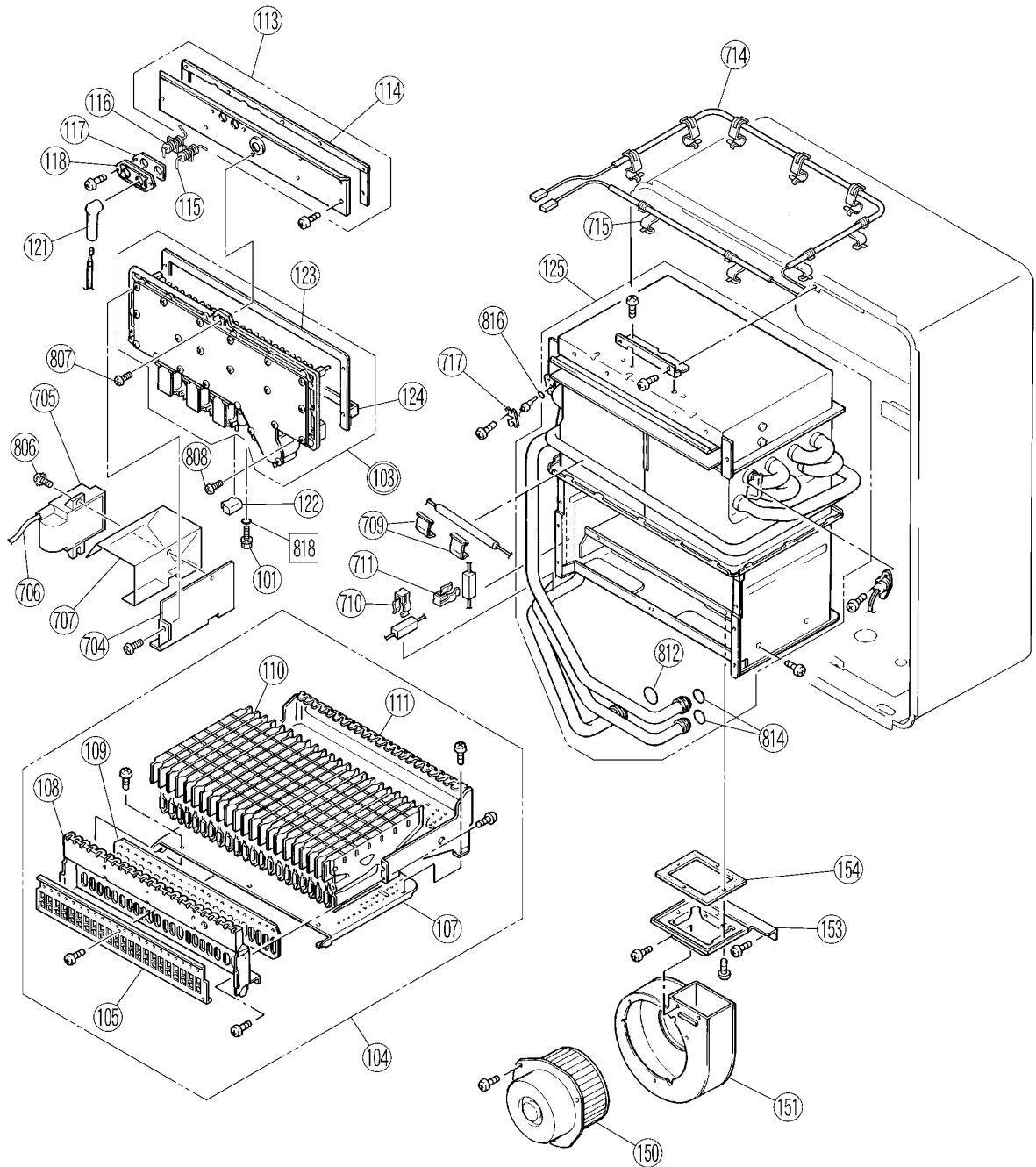

REU-V3237WG-AK / REU-VM3237WC(65)-AK

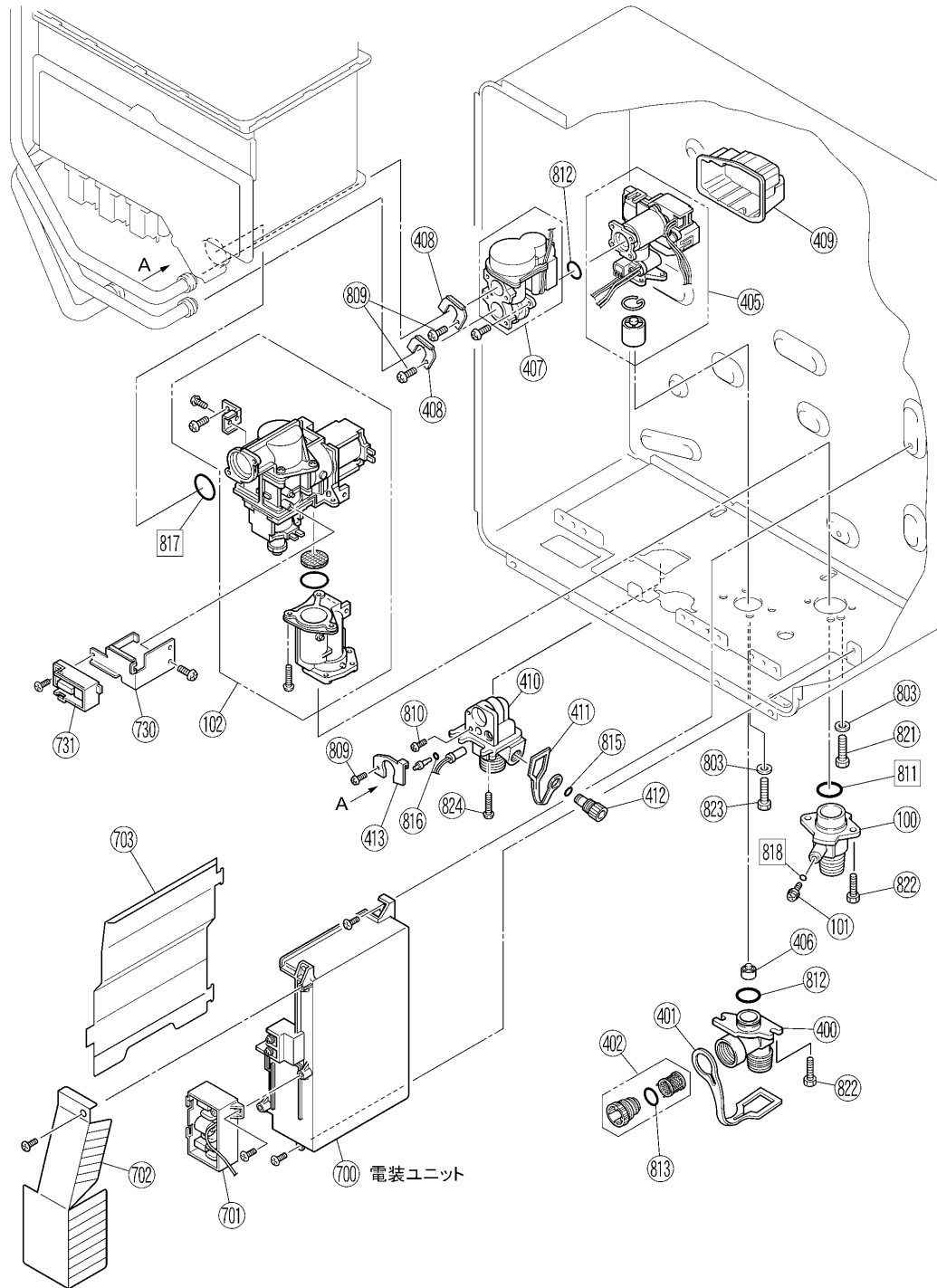

REU-V3237WG-AK / REU-VM3237WC(65)-AK

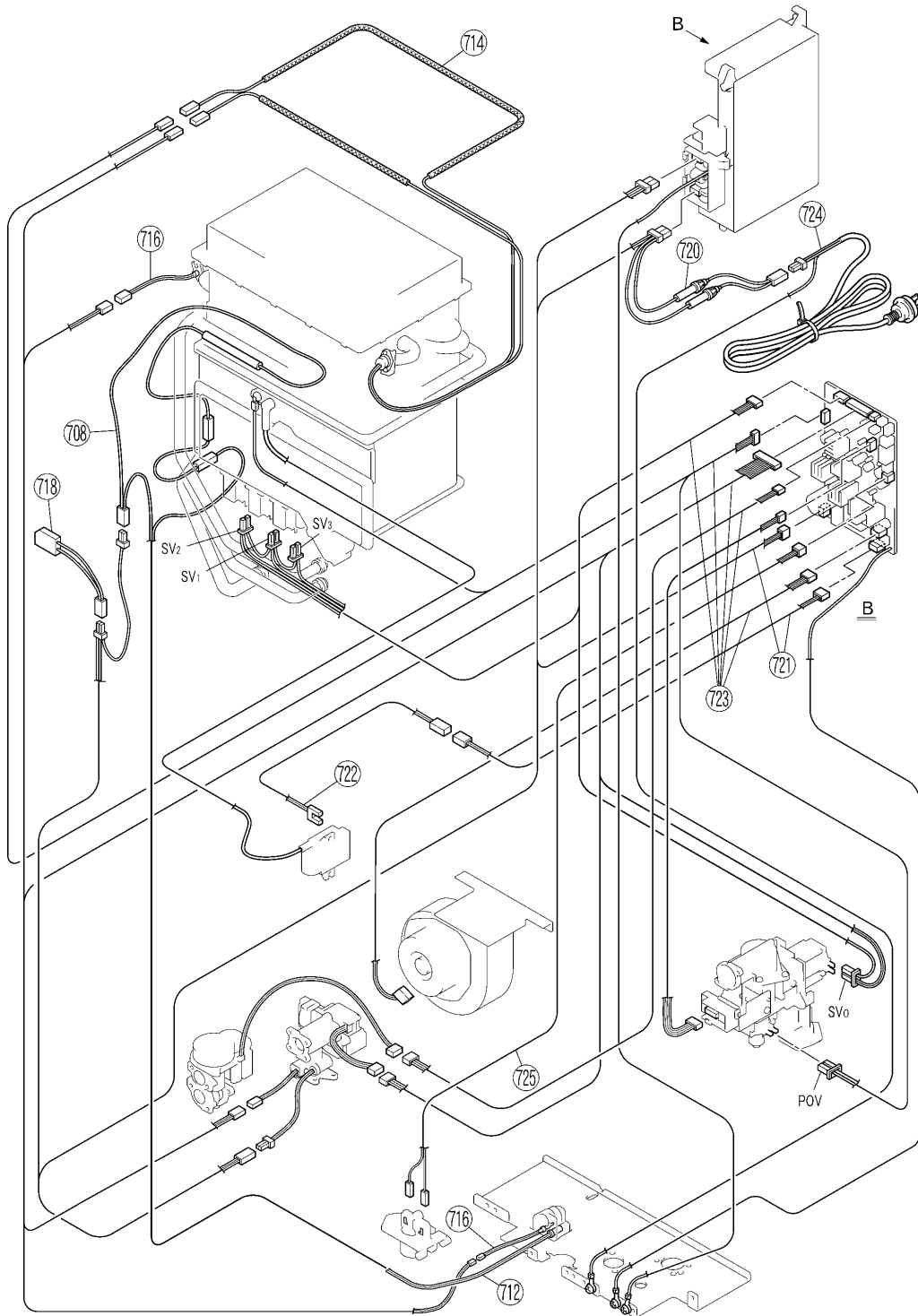

SERVICE CONTACT POINTS

Rinnai

Rinnai Australia Pty. Ltd. ABN 74 005 138 769

Head Office

10-11 Walker Street,
Braeside, Victoria 3195
P.O. Box 460
Tel: (03) 9271 6625
Fax: (03) 9271 6622

Rinnai has a Service and Spare Parts network with personnel who are fully trained and equipped to give the best service on your Rinnai appliance. If your appliance requires service, please call our Hot Water Service Line. Rinnai recommends that this appliance be serviced every 3 years.

Internet: www.rinnai.com.au E-mail: enquiry@rinnai.com.au

National Help Lines

Spare Parts & Technical Info
Tel: 1300 555 545*
Fax: 1300 300 141*

*Cost of a local call Higher from mobile or public phones.

Hot Water Service Line
Tel: 1800 000 340