

# RHEEM RHEEM LOLINE 160L GAS BOOSTED SOLAR WATER HEATER



SOLAR

1 - 4

PEOPLE  
(See Table)

160L

CAPACITY

5  
YEAR

CYLINDER  
COLLECTOR  
(supply only)  
WARRANTY<sup>5</sup>



MODEL NO.  
511161/1CS26-24G

## FEATURES

- **Split System design** – With only one compact sized roof mounted collector, and a 160 litre ground mounted tank, the 511161 can be located out of sight.
- **Continuous flow gas booster** – Enjoy endless, efficient hot water from the standard 24L/min continuous flow booster, or additional hot water from a 27L/min booster remotely installed.
- **High efficiency solar collector** – Resourcefully absorb maximum energy from the sun.
- **Enhanced frost protection** – Electronically controlled circulation of water prevents frost damage.
- **Efficient performance** – With all of its tank capacity available for solar heating, a CSA2612 collector and 6 star efficient gas boosting, calculated energy reduction of up to 60%<sup>1,2</sup> may be achieved.
- **No hard-wiring required** – Thanks to its plug in design, the 511161 saves the additional cost of having an electrician on-site during installation.
- **Complies with regulations** – The 511161 is certified to comply with current new home water heating regulations in Victoria.
- **Integrated solar controller** – Factory fitted, reducing both installation time and complexity.
- **5 year warranty<sup>5</sup>** – Enjoy the peace of mind a comprehensive 5 year warranty<sup>5</sup> provides.
- **Eligible for STCs<sup>4</sup>**

## HOW IT WORKS

Rheem Loline Solar water heaters use roof mounted solar collectors to absorb heat energy from the sun, which is transferred to water stored in the tank at ground level. They are highly efficient, economical to run and help reduce the production of greenhouse gas emissions. The Rheem Loline 160 with automatic electronic controls will provide continuous hot water all year round, even during poor weather periods.



COMES ON STEADY, HOT AND STRONG

INSTALL A



# RHEEM LOLINE 160L GAS BOOSTED SOLAR WATER HEATER

MODEL		511161/1CS26	511161/1LCS 511161/2LCS	511161/1CS26-27G	511161/1LCS-27G 511161/2LCS-27G
Storage Capacity	L	160	160	160	160
Solar Collectors	CSA2612	1	N/A	1	N/A
	LCS	N/A	1 or 2	N/A	1 or 2
Booster Type		Gas – Integrated	Gas – Integrated	Gas –Remote	Gas – Remote
Boost Capacity	L/min	24	24	27	27
People Per Household		2-4	2-4	2-5	2-5
<b>Specifications</b>					
Weight Empty – Tank	kg	73	73	52	52
Weight Full – Tank	kg	239	239	217	217
Weight Empty – Solar Collectors	kg	47	31/62	47	31/62
Weight Full – Solar Collectors (with fittings)	kg	55	37/74	55	37/74

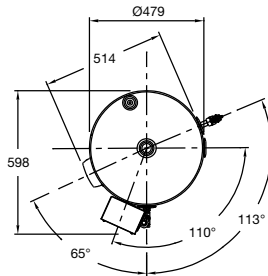
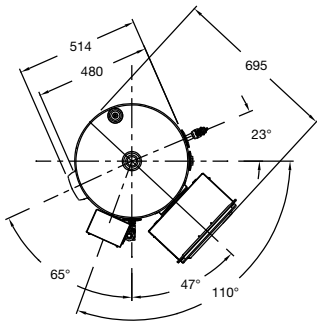

SOLAR COLLECTORS		A	B	C
LCS	mm	1027	1943	82
CSA2612	mm	1130	2285	82

LCS & CSA2612 Solar collectors

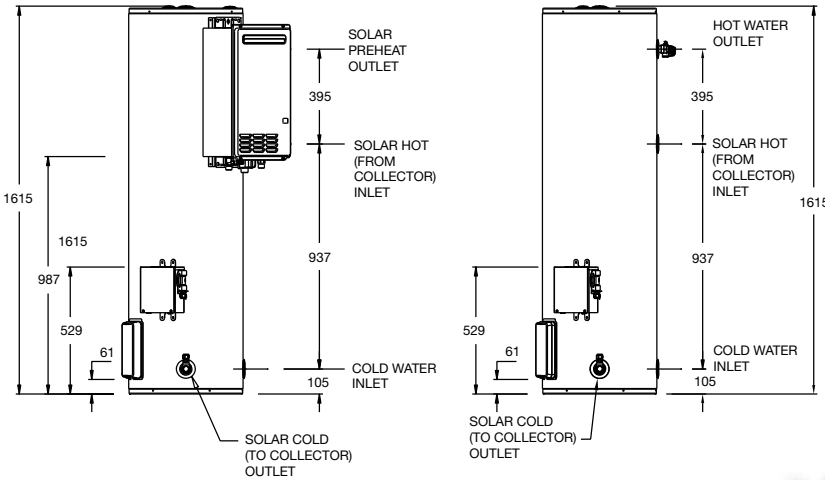
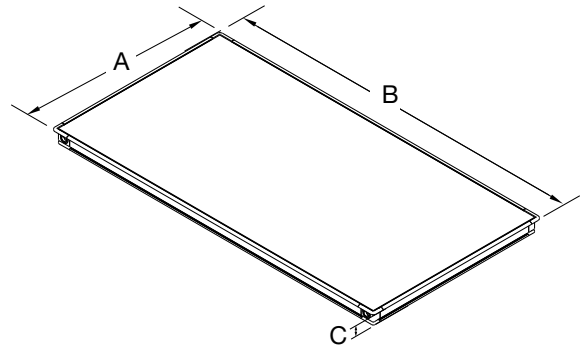

## STCs

Small-scale Technology Certificates (STCs) are a financial benefit to encourage the installation of solar water heaters provided under a Federal Government legislated scheme.

This map shows the climate Zones within Australia which will define the number of STCs allocated to an approved solar water heater. Your installation may be eligible.\*\*

To claim your STC entitlement, simply complete the STC Assignment form. Visit [www.rheems.com.au/rebates](http://www.rheems.com.au/rebates) to download the STC Assignment form.

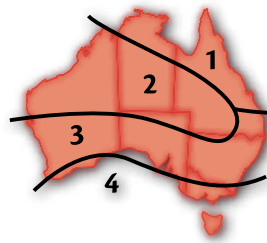

- Energy reduction of up to 60% based on Victorian ESC approved TRNSYS simulation modelling in Zone 4. Savings will vary depending upon your location, type of system installed, type of water heater being replaced, hot water consumption and fuel tariff.
- Any financial savings will vary depending upon type of Rheem Solar system installed, orientation and inclination of the solar collectors, type of water heater being replaced, hot water consumption and fuel tariff. Maximum financial savings off your hot water bill are achievable when replacing an electric water heater on continuous tariff.
- Eligibility criteria apply.
- Warranty Conditions: solar tank – 5 years supply on cylinder and solar collectors, 3 years labour on cylinder, 1 year labour on solar collectors, 1 year supply and labour on other parts; continuous flow gas booster – 10 years supply on heat exchanger, 3 years labour on heat exchanger, 3 years supply and labour on other parts. Applies to a single-family domestic dwelling only. Conditions apply, see Rheem's warranty set out in the product's Owner's Guide or view it at [www.rheem.com.au](http://www.rheem.com.au). Phone 131 031 for details.

Materials and specifications are subject to change without notice.

\* Registered Trademark of Rheem Australia Pty Ltd.

\*\* Trademark of Rheem Australia Pty Ltd.

Certified Product, Certified System and Watermark Logo's are trademarks of SAI Global



Rheem Australia Pty Ltd.

1 Alan Street, Rydalmere, New South Wales 2116, Australia  
PO Box 7508, Silverwater, New South Wales 2128, Australia.

