



# prodigy<sup>®</sup> 3

gas storage specifications

## thinkeasyinstall

A low cost installation offer

## thinkvalue

Now with a 7 year tank warranty



1300 365 116

[www.dux.com.au](http://www.dux.com.au)

# prodigy<sup>®</sup> 3 gas storage

## Why you should choose a Dux Prodigy<sup>®</sup> 3 gas storage system

- Backed by a 7 year tank warranty, including 1 year parts and labour
- 3 star efficiency
- Full mains pressure to all taps
- Easy installation – water connections on both sides of tank
- Adjustable thermostat for safety, efficiency and control over operating costs and performance
- Rapid reheat
- Duro-name<sup>®</sup> tank lining for corrosion protection
- Dux is part of a publicly listed Australian company



## Which Dux gas storage system is right for you?

CAPACITY (LITRES)	PEOPLE
135	3-5
170	4-6

Adult icon can represent dishwasher or washing machine.  
An adult icon does not represent a spa bath.

SPECIFICATIONS	135S	170S
Nominal Capacity (Litres)	135	170
Water Capacity in First Hour* (Litres)	270	305
Net Weight Empty (kg)	72	86
Relief Valve Pressure (kPa)	1400	1400
Gas Consumption (MJ/hr) – Natural Gas	33	33
Recovery Rate* (45°C rise litre/hr) – Natural Gas	135	135
Energy Star Rating	★★★	★★★

\* Temperature rise at 45°C and inlet temperature of 15°C using natural gas

NOMINAL DIMENSIONS (MM)	135S	170S
<b>A</b> Overall Height Outdoor	1601	1896
<b>B</b> Hot Water Outlet	1327	1620
<b>C</b> Cold Water Inlet	221	221
Gas Inlet	336	336

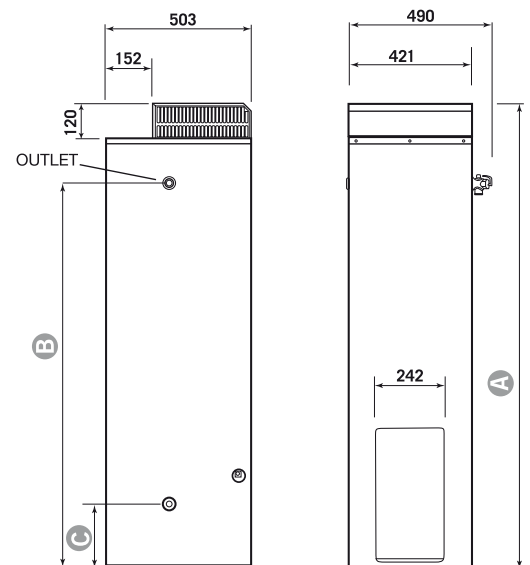

0611



## Contact Dux for your Hot Water Solutions

Sales: 1300 365 116 Service: 1300 365 115 Web Site: [www.dux.com.au](http://www.dux.com.au)  
 ©Dux Manufacturing Limited ABN 19 077 879 844. Lackey Rd, PO Box 209 Moss Vale, NSW 2577  
 The information supplied was correct at time of printing. Specification and materials may change without notice.  
 © and ™ indicate trademarks of Dux Manufacturing Limited. Dux Manufacturing Limited is part of a publicly listed Australian company.

