



CONERGY

## Owners Manual

Conergy Split System

Open and Closed Systems



# Table of Contents

---

<b>1</b>	<b>Owners Information</b>	<b>3</b>
1.1	The environmental benefits	3
1.2	Why Conergy?	3
1.3	What is a Split System?	3
1.3.1	What is an Open Circuit System?	4
1.3.2	What is a Closed Circuit System?	4
1.4	System components	5
1.4.1	Storage Tank & Solar Collectors	5
1.4.2	Ancillary Energy Support (AES) - Booster Systems	5
1.5	Your Conergy AS model number	6
1.6	Important Safety Information	7
1.7	What should I do during holidays?	8
1.8	Why is there general water discharge through the pressure valve?	8
<b>2</b>	<b>Troubleshooting</b>	<b>9</b>
2.1	What should I check before making a service call?	9
2.1.1	Low solar energy input	9
2.1.2	Ancillary Energy Support system (booster) not operating	9
2.1.3	Excessive water discharge from the valves?	9
2.1.4	Are you using more hot water than you think?	9
<b>3</b>	<b>System Maintenance</b>	<b>10</b>
3.1	Pressure limiting valve	10
3.2	Draining the storage tank	10
3.3	Closed Circuit Systems - solar transfer fluid	11
<b>4</b>	<b>Electrical Installation Instructions</b>	<b>12</b>
4.1	Connection for electric AES systems	12
4.1.1	Electrical circuit diagram	12
4.2	Electrical connection for Gas AES Systems	12
<b>5</b>	<b>Gas (AES) Installation Instructions</b>	<b>13</b>
5.1	Approved Gas Heater Models	13
5.2	Commissioning	13
<b>6</b>	<b>Warranty</b>	<b>14</b>

# 1 Owners Information

Congratulations on buying one of the most advanced solar hot water heaters in the world. As the owner of a Conergy solar water heater you may have some questions about the system and how it operates. Your solar water heater model is commonly referred to as an Active, Split or Ground Mounted open circuit or closed circuit system and is one of the most efficient solar water heater types available.

## 1.1 The environmental benefits

A Conergy Solar Water heater is an excellent and economic energy solution as, by using the sun's heat for heating water, we cut down on the amount of fossil fuels burnt to supply electricity to do the same thing.

Any time you use solar energy to offset the amount of fossil fuels that are burned, you contribute to everyone's health and welfare. Operating one solar water heater instead of an electric water heater saves the equivalent of 1400 litres of oil every year and reduces carbon dioxide emissions by up to 3.4 tonnes per year and sulphur dioxide which contributes to acid rain emissions by more than 6kg.\* Multiply those emissions per household by all the homes in your neighbourhood, town and state and the benefits of solar for our environment are enormous.

## 1.2 Why Conergy?

Conergy offers Australia's largest range of renewable energy products and our company operates in 25 countries on 5 continents. Our products are used in hundreds of thousands of homes for Hot Water and Solar Electricity worldwide and we offer the leading products in these technologies.

To sell solar water heaters in Australia, or achieve any of the state or Federal Government rebates, the products must comply with the rigorous Australian Standards for hot water and solar hot water. Our products comply with all of these standards. The Federal Government Renewable Energy Certificate program, called RECs, is an indication of solar efficiency. If you compare any of the Conergy products with an equal competitor model, you will find that Conergy achieves more RECs than any of our competitors.

## 1.3 What is a Split System?

A Split System (also referred to as an Active system) is a system where the heated water in the solar collectors is circulated by a pump, drawing cold water from the storage tank or heat exchanger, pushing it through the collectors and back to the tank or heat exchanger as heated water. The location of the tank can be up to 20 meters from the collectors. The pump requires electricity, but uses a very small proportion of power in comparison to the heat collected by the system. The power consumed is no greater than 28 watts.

There are two types of Conergy active solar water heaters. The operating methods and instructions are similar for both. The two types are; "Open Circuit System" & "Closed Circuit System":

\* Source: Australian Greenhouse Office

1.3.1 What is an Open Circuit System?

An Open Circuit System is one where the water used in the household circulates through the solar collector panels, thus transferring solar energy to the storage tank. This system type is used in locations where the ambient temperature never falls below freezing point (0°C or 32°F) and where the water quality is good – less than 600 ppm Total Dissolved Solids (TDS).

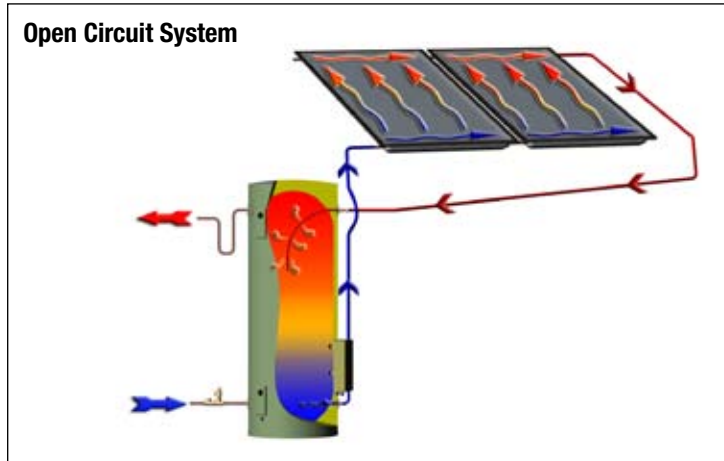

1.3.2 What is a Closed Circuit System?

A Closed Circuit System is a system where two separate circuits are contained within the solar water heater. The first circuit is the household water storage tank which stores the heated household water used within the household. The second circuit is the solar collector circuit which is fully sealed and mechanically separated from the household water circuit by a heat exchanger system. The fluid within the solar collector circuit is a mixture of household water and food grade propylene glycol. This fluid mix transfers solar energy from the solar collectors to the heat exchanger system and prevents damage to the solar collectors should the ambient temperature fall below freezing point. This system type can be used in any climatic location and with any water quality considered suitable for human consumption.

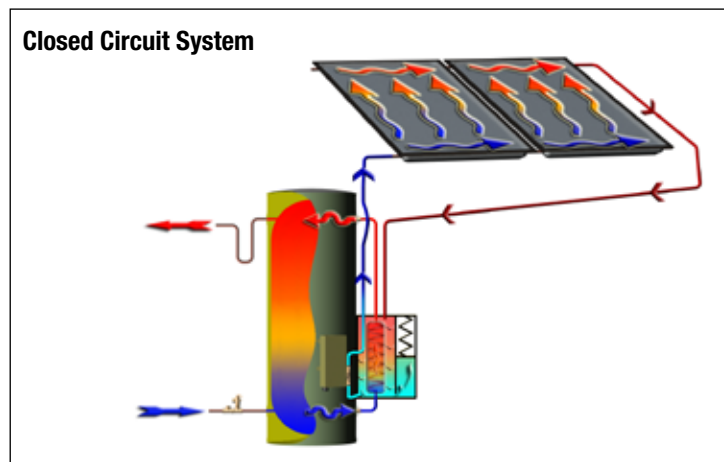

## 1.4 System components

The main components of your solar water heater are the household water storage tank, the solar collector(s), circulation pump module & controller, heat exchange module (closed circuit models only) and the Ancillary Energy Support (AES) System.

### 1.4.1 Storage tank & solar collectors



Open circuit tank, closed circuit tank, solar collectors

The Conergy water storage tank is used to store the heated water ready for household use. It is a standard water heater storage tank, incorporating a high temperature vitreous enamel lining to provide long life, and a high density polyurethane insulation to ensure minimal heat loss.

The solar collectors contain a multi tube copper water way system bonded to a solar absorber plate, the combination of which collects solar energy and transfers it to the fluid within the collector circuit. The absorber plate system is enclosed in an aluminium or zincalume casing covered with a high strength, low iron toughened glass sheet that protects the absorber system from physical damage. Conergy offers 4 collector models with your system. They are:

- | **F20LC** - Selective surface guarantees maximum performance in high solar radiation areas
- | **E20SB** - Semi selective surface on copper substrate for maximum performance in high solar radiation areas, aluminium tray for corrosive environments
- | **E20BC** - Black chrome surface on copper substrate guarantees maximum efficiency, aluminium tray for corrosive environments
- | **E25BC** - 2.5 m<sup>2</sup> surface area black chrome surface on copper substrate guarantees higher efficiency, aluminium tray for corrosive environments

### 1.4.2 Ancillary Energy Support (AES) - Booster Systems

Electricity and gas are the two options for the AES system. The selection of the most suitable AES system type is made at the time of purchase from the Conergy dealer.

For electric AES systems the electric element within the storage tank is automatically controlled by an internal thermostat which will only allow the electric element to operate if the storage tank

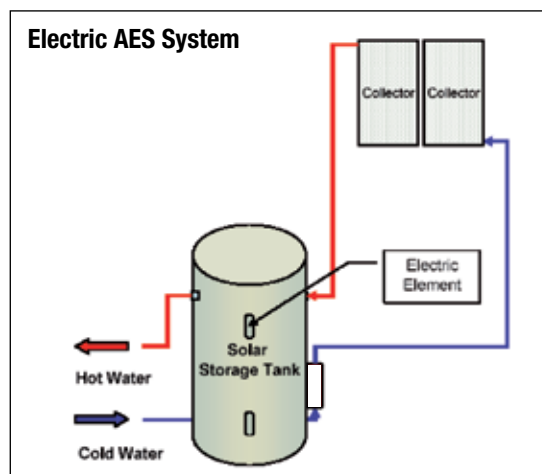

water temperature falls below 60°C and will only consume electricity until the water temperature is increased to 60°C then turns off again.

For gas AES systems a continuous flow gas water heater is fitted adjacent the storage tank in series with the hot water supply from the storage tank and the household hot water pipe work system. As the hot water from the solar storage tank passes through the gas heater its temperature is automatically monitored by the gas heater. If the temperature is below 60°C the gas heater will add the energy required to deliver hot water of at least 60°C. When the water storage tank temperature is above 60°C the gas heater will not ignite.

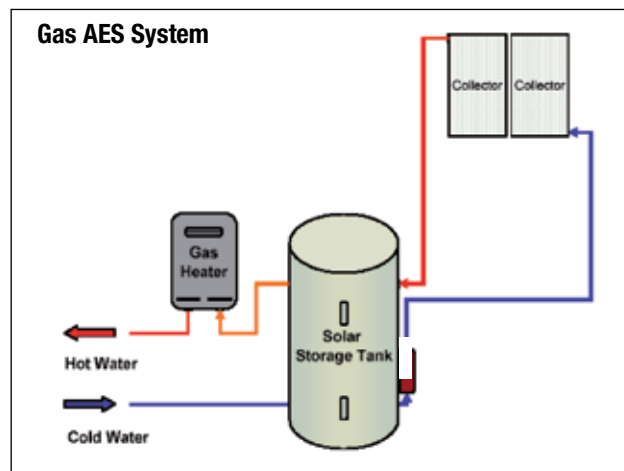

### 1.4.3 Circulation pump

The circulation pump is a simple device used to circulate the water in the collector circuit. This, in turn, enables solar energy from the collectors to be transferred to the storage tank location. The pump consumes only a very small amount of electrical energy (less than 28 watts) to perform this task. The circulation pump has an integral 'non-return valve' to prevent solar energy from reverse cycling back through the storage tank to the collectors at night.

The electronic control device used to control the circulation pump has a complex set of activities. It is the brain of the system and ensures optimum system efficiency and safety. The basic functions are:

1. Detecting availability of useful solar energy in the solar collectors. When the temperature of the solar collector is 6°C higher than the storage tank temperature, the circulation pump is initiated. If the difference in temperature falls to less than 4°C the circulation pump is stopped.
2. Controlling maximum storage tank temperature. If the storage tank temperature reaches 70°C, the circulation pump is stopped to prevent excessive temperatures in the storage tank.
3. Collector maximum temperature limiting. If for any reason the collector temperature reaches 200°C, circulation is stopped to prevent potential damage to the system components.
4. Collector Temperature control. During periods when the circulation pump is idle, and if the

collector temperature rises above 190°C, the circulation pump will be initiated to reduce the collector temperature to below 185°C. This is to protect the collector from prolonged periods of extreme temperature.

5. System Cooling. During the collector circuit temperature control operation, if the storage tank water temperature has risen above the set 70°C maximum, the controller will initiate the pump to reduce the excess tank temperature back to the set point of 70°C. This function is to ensure water temperatures above 70°C are not stored for prolonged periods in the storage tank.

## 1.5 Your Conergy Split System model number

The model number of the system is divided into sections to describe the system which you have installed. For example: AS315/4/0/E24/V/E20SB.

The first two digits are used to determine the system type. eg **AS**315/4/O/E24/V/E20SB.  
AS is an Active (or pumped) system.

The next three digits are used to determine the tank delivery volume. eg AS**315**/4/O/E24/V/E20SB.  
In the example 315 indicates that the delivery volume is a nominal 315 litres. 400 would indicate a nominal delivery volume of 400 litres.

The fourth digit indicates the nominal collector surface area. eg AS315/**4**/O/E24/V/E20SB.  
In the example 4 indicates 4m<sup>2</sup> and 6 would indicate 6m<sup>2</sup>.

The next figure indicates the tank model type. eg AS315/4/**O**/E24/V/E20SB.  
In the example O indicates an open circuit tank system and a C would indicate a closed circuit system.

The next figures indicate the AES model type. eg AS315/4/O/**E24**/V/E20SB.  
In the example E24 indicates an electric 2.4kW AES a G21 would indicate a 21 litre per minute gas AES.

The next figure indicates the tank construction. eg AS315/4/O/E24/**V**/E20SB.  
In the example V indicates a vitreous enamelled tank and an S would indicate a stainless steel tank.

The final 5 figures indicate the Collector model. eg AS315/4/O/E24/V/**E20SB**.  
In the example the collectors are model E20SB. Other models are E20BC, E25BC, F20LC or E20SP.

## 1.6 System operation

A Conergy solar water heater is designed for fully automatic operation, so there is nothing you need to do for day to day system operation. If the AES System has been fitted with a remote isolator switch or time-clock, you may make the decision when and if Ancillary Energy Support is permitted. As a guide you may like to isolate the AES System during the summer months and you may use a time clock to permit boosting after sunset or any other combination, which suits your usage pattern. Careful use of these options can further reduce your energy use for hot water supply to the household.

### 1.7 Important safety information



- | All water heaters have the ability to produce hot water very quickly. To reduce the risk of scald injury it is recommended that a temperature control valve be fitted to the hot water supply pipe work. This valve should be checked at regular intervals to ensure its operation and settings remain correct. Please check that the pressure & temperature relief valve relief pipe is not located where it can cause damage if hot water is discharged.
  
- | This water heater is not intended for use by young children or infirm persons without supervision. Young children should always be supervised to ensure that they do not play with hot water taps or the water heater.
  
- | If the hot water system is not used for two weeks or more, a quantity of hydrogen gas, which is highly flammable, may accumulate in the water heater. To dissipate this gas safely, it is recommended that a hot tap be turned on for several minutes at a sink, basin or bath but not a dishwasher, clothes washer, or other appliance. During this procedure there must be no smoking, open flame or any other electrical appliance operating nearby. If hydrogen is discharged through the tap, it will probably make an unusual noise as with air escaping. Do not place hands or any part of your body beneath the tap during this procedure.
  
- | For closed circuit systems, if the water seems red in appearance it could mean that there is a leakage of glycol from the jacket into the main water tank. Please contact your authorised Conergy dealer or installation service provider as soon as possible.

### 1.8 What should I do during holidays?

If you are going to be away for a week or more during the summer months, it is advisable to turn off the electricity supply to the AES System. The power supply to the solar controller pump module must be left ON, so that the system can monitor and control the solar collector temperature while you are away. Whilst the system is safe with the power turned OFF, the collector can reach very high temperatures, causing high stress to their internal components.

### 1.9 Why is there water discharge through the pressure valve?

All Conergy solar water heaters have either one or two pressure valves in the water pipe work. For solar water heaters that only have a Pressure & Temperature valve located on the storage tank it is normal for a small water discharge to occur during the heating cycle of the system. The water discharge is water expanding due to the heating process. Normally the discharge will be less than 10 litres per day.

For systems that have both a pressure & temperature valve and a cold water expansion valve located in the cold water supply pipe work, the expansion discharge will occur from the cold water expansion valve.



## 2 Troubleshooting

It is important to know that there are no user serviceable components in the system, and as such, it is recommended that no covers be removed and no adjustments made to the system settings by anyone other than an authorised Conergy representative.

### 2.1 What should I check before making a service call?

If there is not enough hot water, it is recommended that the following points are considered before making a service call. If after checking the following points the problem has not been identified, please contact the Conergy distributor from whom you purchased the system.

#### 2.1.1 Low Solar Energy Input / Shading

If there have been prolonged periods of cloudy weather, or winter is approaching, it may be necessary to reconsider the permitted AES allowance for time-clock controlled systems, turn on the AES for systems with a booster isolation switch or turn on the gas supply to gas AES models.

Often trees or other buildings can shade the solar collectors, or there can be a dirt build up on the glass cover. Trees should be cut back if possible, or the system relocated if removal of the shading is not possible, in the present location. If the glass is dirty, this should be cleaned with any normal domestic glass cleaner.

#### 2.1.2 Ancillary Energy Support (Booster System) not operating

For electric systems, the fuse, circuit breaker supplying the AES System should be checked.

If the time clock (where fitted) and the fuse or circuit breaker are operational and the water is cold, you can turn the booster isolator on and off to see if the electricity meter speed changes. If there is no change in speed, it indicates there may be a booster problem and a service call will be necessary. It is important to remember – Do not open or adjust any electrical covers or devices yourself.

For gas systems the gas and electric supplies to the gas heater should be checked to ensure they are both on. If water temperature from the gas heater is below 60°C and both supplies are on and the gas heater does not ignite there may be a problem and a service call will be necessary.

#### 2.1.3 Excessive water discharge from the Valves?

If there is a discharge of more than 10 litres per day from any of the system's valves, it indicates there is a problem that requires a service call.

#### 2.1.4 Are you using more hot water than you think?

Often the hot water usage of showers, washing machines and dishwashers is under estimated. Review these appliances to determine if your daily usage is greater than the storage volume of your water heater. Refer to the section "What system do I have?" to determine the storage volume of your water heater. It is also advisable to inspect tap washers etc. for leakage and replace if necessary.

### 3 System Maintenance

The Conergy system is designed so that there is little to do regarding system maintenance. Personally inspecting or servicing the system is not recommended.

Should you decide to personally inspect the roof mounted solar collectors it is essential that you use all safety devices required to ensure your safety. Glass cleaning usually occurs by natural rainfall. However, if the installation is in an industrial (or similar) area with high levels of airborne particles then a qualified person can clean the collector glass with normal window cleaning chemicals and equipment. If rainwater collection occurs from the same roof on which the solar collectors are located, extra care must be taken to avoid contamination if using chemical cleaning agents.

The lever on the tank relief valves should be operated at least every six months. Failure to do so may result in failure of the tank. If water does not discharge freely from the valves they should be checked by the local service agent. The relief valves and relief valve drain lines must not be blocked. Some water may discharge during each heating cycle.

Every five years you should contact the local service agent to replace all safety valves to ensure continued life and operational safety of the system. In locations where the potable water has a Total Dissolved Solids (TDS) of greater than 600 ppm it is recommended to replace all safety valves every 3 years.

The high quality vitreous enamel lined low carbon steel tanks have a sacrificial anode for long tank life. This anode should be inspected every few years and be replaced when it has worn out. As a minimum it is recommended that the anode be changed every 5 years.

#### 3.1 Pressure limiting valve

Where the water supply pressure is greater than 550 kPa, a 500 kPa pressure limiting valve must be fitted to limit the supply pressure. As stated previously – personally servicing the system is **NOT** recommended.

#### 3.2 Draining the storage tank



All plumbing work should be carried out by a licensed tradesperson. To drain the water from the storage tank the following procedure is to be followed:

1. Turn off and isolate the power supply to the electrical element.
2. Turn off the water supply to the water heater.
3. Release excess pressure from the tank by manually opening the pressure & temperature relief valves.
4. Disconnect the cold water supply pipe connection to the tank.
5. Fit a ½" flexible drain pipe to the cold connection on the tank. Place the open end of the drain hose in a location where it is safe for the hot water to drain away from the tank.

6. Manually open the pressure and temperature relief valve which will allow air into the tank. The water within the tank will flow out via the flexible drain pipe fitted to the cold inlet connection. Hold the valve open until the tank is empty.

### 3.3 Closed Circuit Systems - solar transfer fluid

When filling the heat exchanger with glycol **it is essential** that the main tank is filled with water prior to commencing.

#### Approved Solar Transfer Fluid details

Name: St-5 Solar Transfer Fluid

Description: Propylene Glycol

Appearance: Red Liquid

### 4 Electrical Installation Instructions



- | All electrical work must comply with local regulations.
- | All electrical work must be conducted by a suitably licensed electrician.

#### 4.1 Connection for electric AES systems

- | The electric element is only connected in models using an electric AES system. No connection is made to the electric element for gas AES systems.
- | The electrical booster requires a 220 – 250 volt single phase AC power supply with a capacity suitable for the kilowatt rating of the element selected for the application. eg: a 3.6 kW element requires a 15 amp supply capacity.
- | The power supply must be protected by an individual fuse or circuit breaker rated to suit the booster size. The supply to the solar water heater can be operated directly from the switchboard or via a remotely mounted switch or time clock as requested by the customer.
- | Final electrical connection at the solar water heater tank must be made via an electrical disconnection device (eg isolator) and connected at the tank as follows: The earth wire is connected to the earth stud marked with an earth symbol, the active wire is connected to the thermostat terminal marked (L) and the neutral wire is connected to the thermostat terminal marked (N).



**DO NOT turn on the power supply until the solar water heater has been filled with water and pressurised.**

##### 1.4.1 Electrical Circuit Diagram

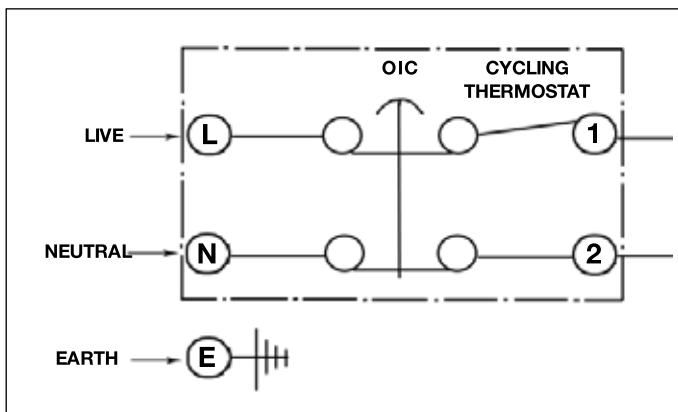

#### 4.2 Electrical connection for gas AES Systems

For models using a gas AES system the electrician is required to install a domestic electrical outlet socket adjacent the gas heater location. The gas heater requires a 220-240 volt 50 Hz power supply and is rated at 0.47 amperes.

### 5 Gas (AES) Installation Instructions

- | All gas work must comply with local regulations including AS5701/AG601 and AS/NZ 3500.4.
- | All gas work must be conducted by a suitability licensed gas fitter.
- | Installation of the gas heater must be carried out in accordance with the installation instructions supplied with the gas heater.
- | Conergy systems only use approved gas heaters.
- | Particular attention must be given to the gas supply system in order to ensure there is a sufficient gas supply available to the gas heater when operating at full output burner rate.

#### Approved gas heater models

Gas heater models used with Conergy solar water heater systems must be certified to all local requirements, be automatic ignition and have full flame modulation. Gas heaters other than this type must not be used with a Conergy solar water heater. Particularly fixed pilot and fixed flame models must not be used under any circumstances.

#### Commissioning

When all connections have been completed the split system can be filled with water.

1. Before turning on the cold water supply open one hot tap within the household to release air from the system during the filling process. Do not leave the open tap unattended during the filling process.
2. Turn on the cold water supply and wait for the system to fill. When water flows without air bursts from the open hot tap it can be closed which will pressurise the solar water heater system.
3. Once the system is pressurised all connections on the water heater must be checked for leaks and repaired if necessary.
4. When the system is proven water tight, power and gas can be applied to the AES system. To test that the element is operational, turn the circuit breaker in the switch board on and off, you should see the power meter's speed change during this action if a disc type meter is installed. For gas AES systems turn on a hot water tap and the gas heater will ignite provided the water temperature is less than 60 °C.

The solar water heater is now fully operational. Enjoy your Conergy Split System.

## 6 Warranty

The Conergy Solar hot water system that you have purchased comes with a comprehensive 5 year parts and labour warranty.

The terms of the Warranty and Guarantee are set out below.

1. Your solar hot water system and its components are covered by a 5 year warranty against defective factory parts or workmanship from the date your hot water unit or solar collector is installed. If the date of installation is unknown, the warranty commences 1 month after the date of manufacture (which can be found on the serial plate on the hot water unit and solar collector).
2. This warranty is for normal use of the solar hot water system and covers the repair and/or replacement of any failed component in the hot water unit and solar collector or where necessary, the hot water unit and solar collector itself. Under this warranty Conergy will repair or replace the component or hot water unit or solar collector free of charge (except for certain transport or travelling time costs which may be payable by the owner under clause 9 below). The decision to repair or replace the component or hot water unit or solar collector will be entirely at the discretion of Conergy.
3. The warranty only applies to defects in the hot water unit and solar collector which have arisen solely due to faulty materials or workmanship.
4. Installation of your Conergy solar hot water system is not covered under this product / manufacturers warranty and in cases of installation failure please contact your original installation service provider.

### 5. 5 Year Guarantee

If any component of the system fails during the initial 5 year warranty period Conergy will replace the failed components free of charge. (except for certain transport or travelling time costs which may be payable by the owner under clause 9 below).

### 6 Scope of Warranty and Guarantee

The warranty and replacement guarantee do not apply to any defects or damage not due to faulty factory parts or workmanship, installation, including but not limited to defects or damage caused by or resulting from:

- 6.1 Accidental damage, abuse, misuse, maltreatment, abnormal stress or strain, harsh or adverse water conditions, contamination or corrosion from particles in the water supply, excessive water pressure, over temperature or neglect of any kind to the hot water unit and solar collector or their components.
- 6.2 Alteration or repair of the hot water unit or solar collector other than by an approved Conergy agent or a technician of a gas or electricity utility approved by Conergy.
- 6.3 Attachment of any parts or accessories other than those manufactured or approved by Conergy.
- 6.4 Faulty or improper installation of the hot water unit or solar collector, including installation otherwise than in accordance with the instructions contained in the Owner's Manual and Installation Manual supplied by Conergy.
- 6.5 Collector glass is not covered by this warranty.
- 6.6 Where hot water temperature & pressure relief valve, cold water expansion valve, check valve and strainer is not fitted in areas where mains pressure is likely to exceed 550 kPa.
- 6.7 Where a closed circuit heat exchanger is not filled with the correct concentration of ST-5 heat transfer fluid in accordance with instructions.
- 6.8 In case of overpressure of closed circuit system beyond the 300kPa maximum working pressure.
- 6.9 Where closed circuit has had water addition not in accordance with water quality specifications; and

- 6.10 Freeze damage to open circuit systems when installed in frost affected areas.
7. The warranty only applies to the hot water unit and solar collector or components in the hot water unit and solar collector and does not cover any plumbing or associated parts, including but not limited to; pressure limiting valves, stop cocks, non return valves, electrical switches, pumps or fuses, supplied by any person installing the hot water unit or solar collector.
  8. Where a hot water unit and solar collector or a component in a hot water unit or solar collector is replaced by Conergy, the balance of any original warranty or replacement guarantee period will remain effective. The replacement part or hot water unit or solar collector does not carry any additional warranty or replacement guarantee.
  9. Where the solar hot water system is located outside the metropolitan area of a capital city and is:
    - | More than 25 kilometres from a Conergy office; or
    - | More than 25 kilometres from a Conergy agent.
    - | The owner will be responsible under the warranty, for paying the costs of transporting the hot water unit or solar collector or any component in the hot water unit or solar collector to and from an approved Conergy agent or to a Conergy office (including the costs of any insurance associated with that transport) or paying the travelling time of an approved Conergy agent to and from the owner's house premises.
  10. Where the warranty applies but the hot water unit and solar collector is installed or located in a position that does not comply with the installation instructions or any relevant statutory requirements, the owner of the solar hot water system will be responsible for the costs of:
    - | The dismantling or removal of cupboards, doors, walls of special equipment and;
    - | Any labour required to gain access to and to bring the system/unit to a position that complies with the installation instructions or relevant statutory requirements.
  11. Conergy's obligations under this warranty and guarantee are limited to repairing or replacing the hot water unit and solar collector or components. To the extent permitted by law, Conergy will not be liable for any loss or damage to furniture, carpets, walls, foundations or any other consequential loss of any kind caused by a defect in the hot water unit and solar collector or any component.
  12. Any claim under the warranty or replacement guarantee must include full details of the defect and/or damage to the hot water unit and solar collector or components in the hot water unit and solar collector. All claims must be made within one month of the detection of the defect.
  13. In addition to this warranty and guarantee, certain legislation (including the Trade Practices Act 1974 and consumer protection legislation of the States and Territories) gives the owner certain rights, which cannot be excluded, restricted or modified. Nothing in this warranty and replacement guarantee has the effect of excluding, restricting or modifying those rights.
  14. In the case of a solar hot water system acquired for other than personal domestic or household use, Conergy's liability for a breach of a condition or warranty implied by Division 2 of Part V (other than Section 69) of the Trade Practices Act (1974) and any equivalent State or Territory legislation is expressly limited to any one or more of the following, as determined by Conergy:
    - | The replacement of the hot water unit and solar collector.
    - | The repair of the hot water unit and solar collector.
    - | The payment of the cost of replacing the hot water unit and solar collector or of acquiring an equivalent hot water unit and solar collector.
    - | Payment of the cost of having the hot water unit and solar collector repaired.

# Solar Power

Harness the sun's energy to help power your life!

## Benefits for you

- | Generating your own electricity helps reduce your electricity bill
- | Federal Government & Renewable Energy Certificate (REC) rebates
- | Producing clean electricity reduces greenhouse gas emissions
- | Add value to your home
- | Helps to meet energy requirements for new homes

(eg. NSW BASIX, 5 star rating systems)



Huge Australian government rebates help you save money

## CONERGY SUN EASY GRID CONNECT KITS - POWERING YOUR HOME



Solar power is the cleanest, most viable form of renewable energy available to help power your house.

When the sun is shining solar modules generate electricity. The inverter feeds this energy to the local grid. At night, your house

draws energy from the grid. Essentially, your electricity meter spins backwards during the day and forwards at night.

Systems are available in various configurations to suit any requirement and budget. Contact us today for more information.

OUR WORLD IS FULL OF ENERGY.

For solar power enquiries, please call 1300 551 303  
For solar hot water enquiries, please call 1300 724 516  
[www.conergy.com.au](http://www.conergy.com.au)

For solar power enquiries in New Zealand, please call 09 489 8100  
For solar hot water enquiries in New Zealand, please call 09 820 8480